

# Duobond Display Technology Co.,Ltd

## PRODUCT SPECIFICATION

MODEL NAME: DBW070AIV40R10

Date: 2022/06/30

Version: 1.0

Preliminary Specification

Final Specification

FOR CUSTOMER	
CUSTOMER APPROVED	

PREPARED BY	CHECKED BY	APPROVED BY	DATE

### Record of Revision

Version	Revise Date	Page	Content
V1.0	2022/ 06/ 30		Initial release.

## Contents

1. General Specifications .....	4
2. Pin Assignment .....	5
3. Operation Specifications .....	7
3.1. Absolute Maximum Ratings .....	7
3.2. Typical Operation Conditions .....	7
3.3. Power Sequence .....	8
3.4. Timing Characteristics .....	10
3.4.1. Timing Conditions .....	10
3.4.2. Timing Diagram .....	10
4. Optical Specifications .....	12
5. Reliability Test Items .....	15
6. Mechanical Drawing .....	16
7. Package Drawing .....	17
8. Visual Specification .....	18
9. General Precaution .....	20

# 1. General Specifications

No.	Item	Specification	Remark
1	LCD size	7.0 inch(Diagonal)	
2	Driver element	a-Si TFT active matrix	
3	Resolution	800X3(RGB)X480	
4	Display mode	Normally Black	
5	Dot pitch	0.0635(W)X0.1905(H) mm	
6	Active area	152.4 (W)X91.44 (H) mm	
7	Module size	165(W)X104.09(H)X5.3 (D) mm	Note 1
8	Surface treatment	Anti-Glare	
9	Color arrangement	RGB-stripe	
10	Interface	Digital (TTL)	
11	Backlight power consumption	2.7 W (Typ.)	Note 2
12	Panel power consumption	0.66 W (Typ.)	Note 3
13	Weight	T.B.D.	

Note 1: Refer to Mechanical Drawing.

Note 2: Including LED Driver power consumption.

Note 3: Including T-con power consumption.

## 2. Pin Assignment

Pin No.	Symbol	Description	Remark
1	GND	Power Ground	
2	GND	Power Ground	
3	NC	Not Connect	
4	Vcc	Power Supply for Digital Circuit	
5	Vcc	Power Supply for Digital Circuit	
6	Vcc	Power Supply for Digital Circuit	
7	Vcc	Power Supply for Digital Circuit	
8	NC	Not Connect	
9	DE	Data Enable	
10	GND	Power Ground	
11	GND	Power Ground	
12	GND	Power Ground	
13	B5	Blue Data 5 (MSB)	
14	B4	Blue Data 4	
15	B3	Blue Data 3	
16	GND	Power Ground	
17	B2	Blue Data 2	
18	B1	Blue Data 1	
19	B0	Blue Data 0 (LSB)	
20	GND	Power Ground	
21	G5	Green Data 5 (MSB)	
22	G4	Green Data 4	
23	G3	Green Data 3	
24	GND	Power Ground	
25	G2	Green Data 2	
26	G1	Green Data 1	
27	G0	Green Data 0 (LSB)	
28	GND	Power Ground	
29	R5	Red Data 5 (MSB)	
30	R4	Red Data 4	
31	R3	Red Data 3	
32	GND	Power Ground	
33	R2	Red Data 2	
34	R1	Red Data 1	
35	R0	Red Data 0 (LSB)	
36	GND	Power Ground	
37	GND	Power Ground	
38	DCLK	Clock Signals ; Latch Data at the Falling Edge	
39	GND	Power Ground	
40	GND	Power Ground	

Note: User's connector part number is **MT-FP430N-2FR** manufactured by UJU or equivalent.

**Backlight Driving Part**

Pin No.	Symbol	Description
1	VLED+	Red, LED_ Anode
2	VLED-	White, LED_ Cathode

Note: The backlight interface connector is a model **SM02B-BHSS-1-TB** manufactured by JST or equivalent. The matching connector part number is **BHSR-20VS-1** manufactured by JST or equivalent.

**BLOCK DIAGRAM**

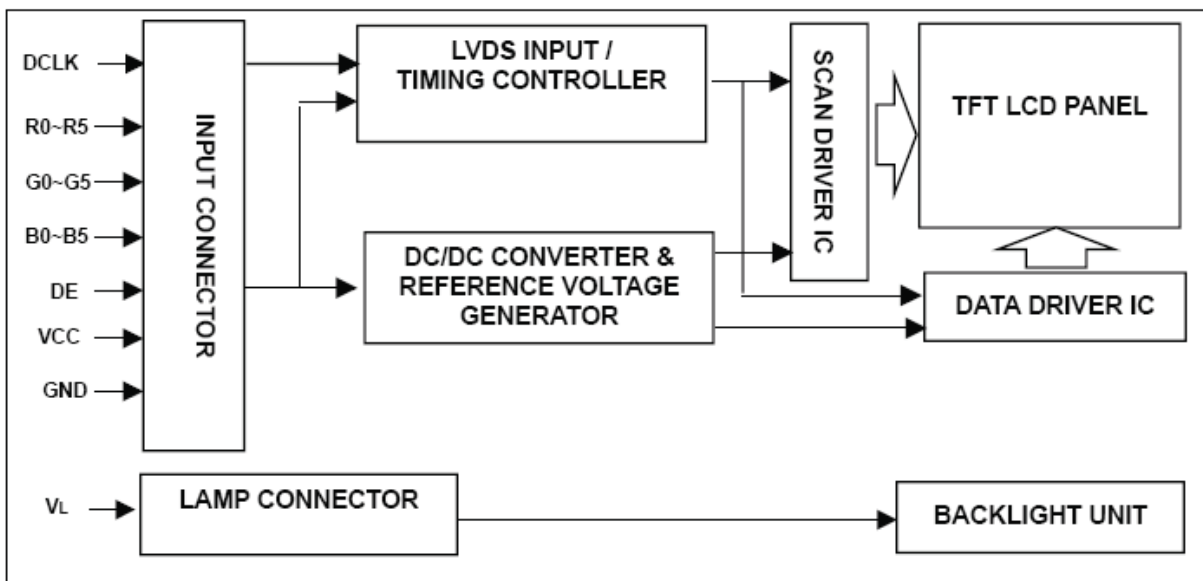

Scanning direction refer to the figure below.

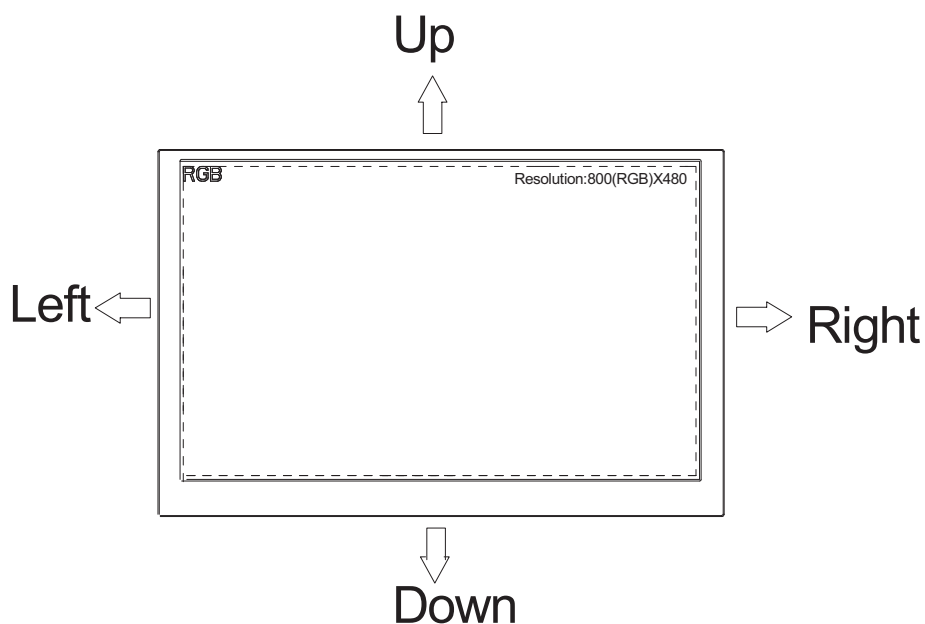

## 3. Operation Specifications

### 3.1. Absolute Maximum Ratings

Item	Symbol	Values		Unit	Remark
		Min.	Max.		
Power voltage	$V_{CC}$	-0.3	6.0	V	
Input signal voltage	$V_I$	-0.3	6.3	V	
Operation Temperature	$T_{OP}$	-30	+85	°C	
Storage Temperature	$T_{ST}$	-40	+90	°C	

### 3.2. Typical Operation Conditions

Item	Symbol	Values			Unit	Remark
		Min.	Typ.	Max.		
Power voltage	$V_{CC}$	3.1	3.3	3.5	V	Note 1
Current consumption	$I_{CC}$	-	200	260	mA	
	$I_F$	-	160	-	mA	Note 2
Input logic high voltage	$V_{IH}$	$0.7V_{CC}$	-	V	V	Note 3
Input logic low voltage	$V_{IL}$	0	-	0.3V	V	
LED life time	-	20,000	-	-	Hr	Note 4

Note1:  $V_{CC}$  setting should match the signals output voltage (refer to Note 4) of customer's system board.

Note 2: LED driving current.

Note 3 : DCLK,DE, HS, VS, R0~ R5,,G0~ G5,B0~ B5.

Note 4: The "LED life time" is defined as the module brightness decrease to 50% original brightness at  $T_a=25$  and  $I_{LED}=160$  mA . The LED lifetime could be decreased if operating  $I_{LED}$  is larger than 160 mA .

### 3.3. Power Sequence

The LCD adopts high voltage driver IC, so it could be permanently damaged under a wrong power on/off sequence. The suggested LCD power sequence is below:

**Panel Power on sequence:**

Parameter	Value			Unit
	Min.	Typ.	Max.	
T1	--	--	20	ms
T2	1	--	--	ms
T3	20	--	--	ms
T4	1	--	--	ms
T5	1	--	--	ms
T6	1	--	--	ms
T7	1	--	--	ms
T8	--	--	80	ms

VDD → Digital Input & RESET → AVDD & SPI → VGL → VGH → VCOM → LED

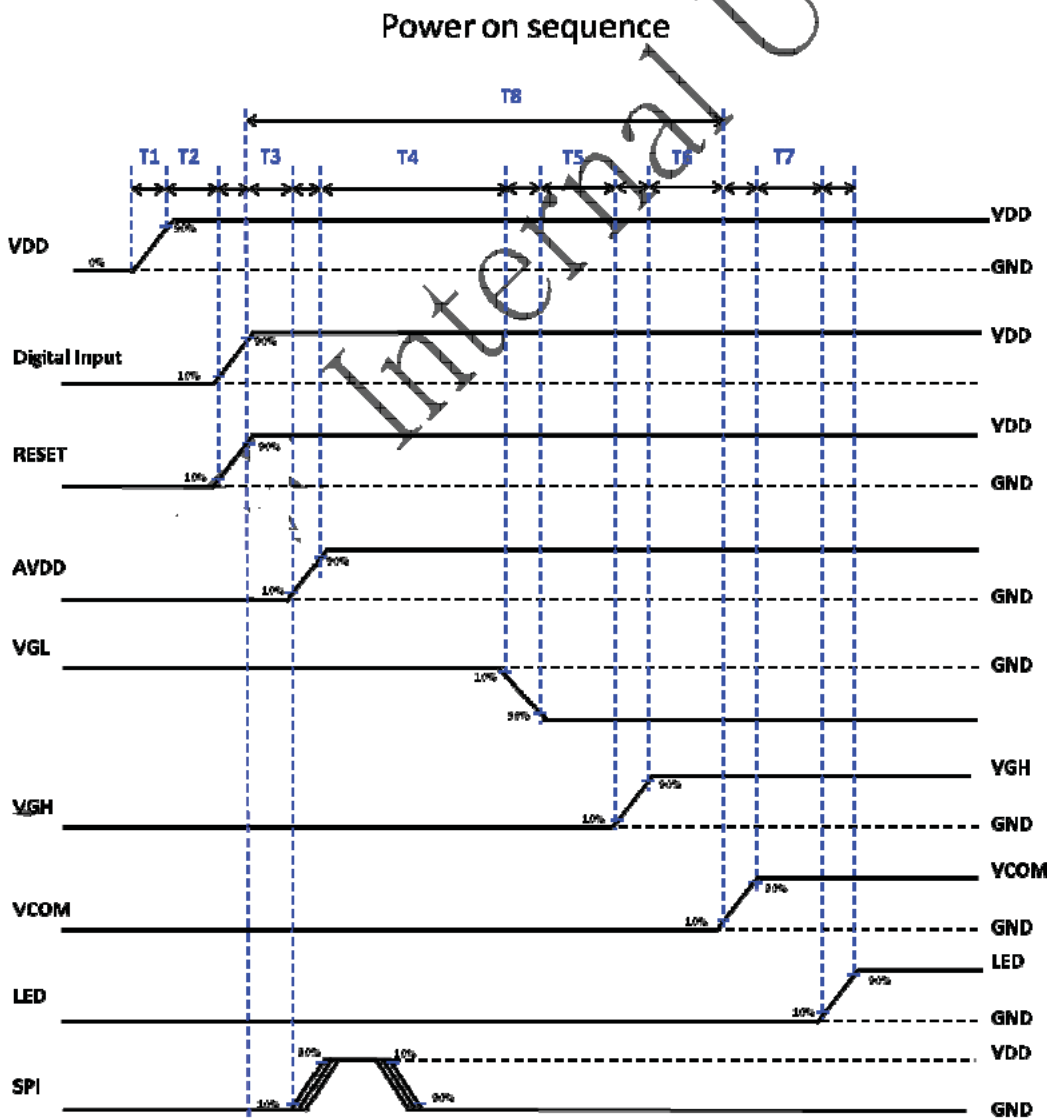

Note: Reset signal must rising after VDD signal

**Panel Power off sequence:**

Parameter	Value			Unit
	Min.	Typ.	Max.	
T1	0	--	-	ms
T2	0	--	16	ms
T3	0	--	16	ms
T4	0	--	1	ms
T5	0	--	1	ms
T6	40	--	--	ms

LED → Digital Input → RESET → AVDD & VCOM → VGH → VGL → VDD

**Power off sequence**

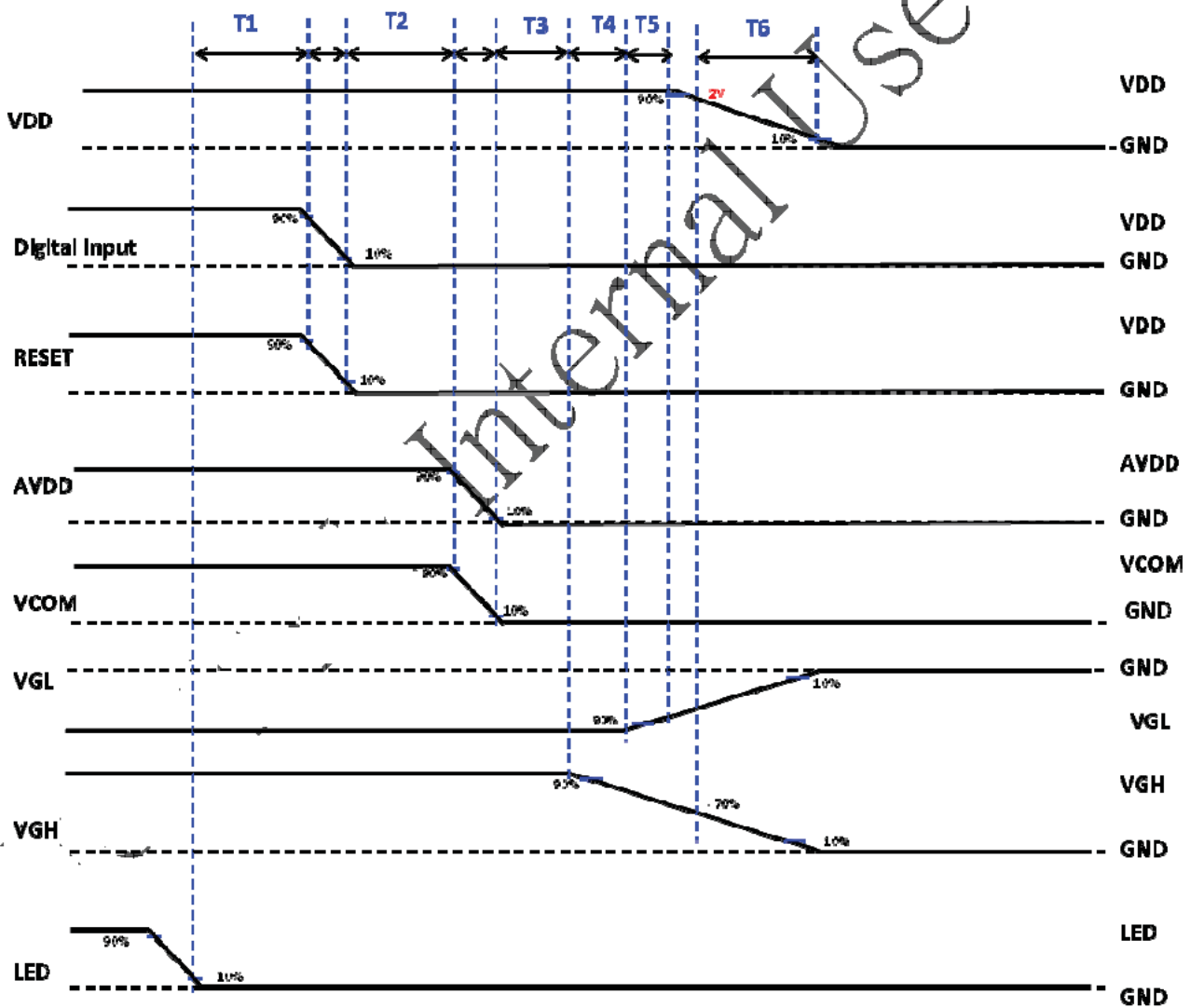

Note: VDD=2V, VGH > 70%  
All signal must be discharge to zero voltage when power off.

### 3.4. Timing Characteristics

#### 3.4.1. Timing Conditions

Item	Symbol	Min	Typ	Max	Unit	Remark
Clock frequency	$F_{CLK}$	27.027	29.988	40.0	MHz	
Vertical display area	$T_{VD}$	480			H	
Vertical period area	$T_V$	525	525	530	H	
Vertical blanking area	$T_{VB}$	45	45	50	H	Note1
Vertical pulse width	$T_{VPW}$	3			H	
Vertical back porch	$T_{VBP}$	20			H	
Vertical front porch	$T_{VFP}$	25	25	30	H	
Horizontal display area	$T_{HD}$	800			dclk	
Horizontal period area	$T_H$	858	952	1258	dclk	
Horizontal blanking area	$T_{HB}$	58	152	458	dclk	Note2
Horizontal pulse width	$T_{HPW}$	3			dclk	
Horizontal back porch	$T_{HBP}$	48			dclk	
Horizontal front porch	$T_{HFP}$	10	104	410	dclk	
HS setup time	$T_{HSU}$	6	-	-	ns	
HS hold time	$T_{HHD}$	6	-	-	ns	
VS setup time	$T_{VSU}$	6	-	-	ns	
VS hold time	$T_{VHD}$	6	-	-	ns	
Data setup time	$T_{DSU}$	6	-	-	ns	
Data hold time	$T_{DHU}$	6	-	-	ns	
DE setup time	$T_{ESU}$	6	-	-	ns	

Note1:  $T_{VB} = T_V - T_{VD}$

Note2:  $T_{HB} = T_H - T_{HD}$

#### 3.4.2. Timing Diagram

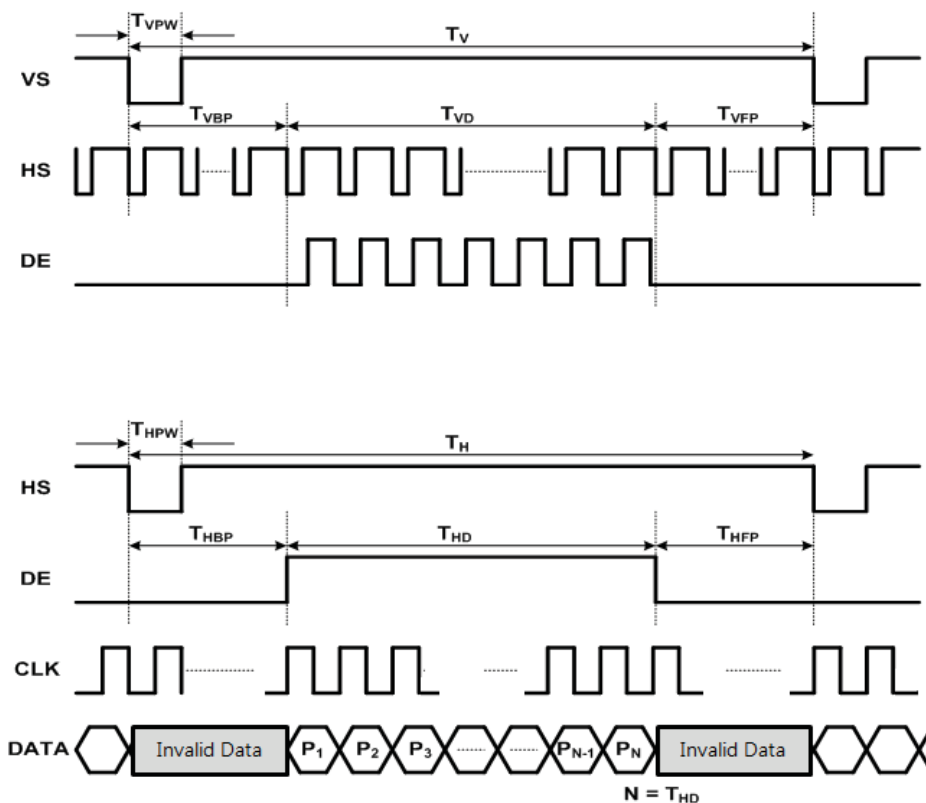

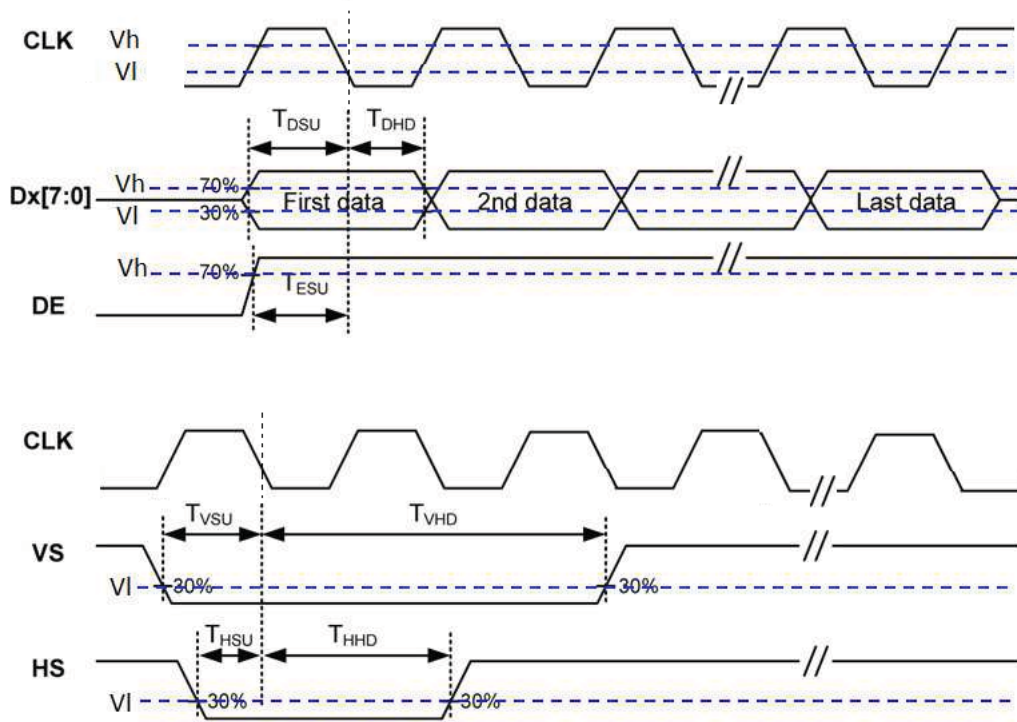

Note : Latch data at CLK Falling Edge.

## 4. Optical Specifications

Item	Symbol	Condition	Values			Unit	Remark
			Min.	Typ.	Max.		
Viewing angle (CR ≥ 10)	$\theta_L$	$\Phi=180^\circ$ (9 o'clock)	70	80	-	degree	Note 1
	$\theta_R$	$\Phi=0^\circ$ (3 o'clock)	70	80	-		
	$\theta_T$	$\Phi=90^\circ$ (12 o'clock)	70	80	-		
	$\theta_B$	$\Phi=270^\circ$ (6 o'clock)	70	80	-		
Response time	$T_{ON}$	Normal $\theta=\Phi=0^\circ$	-	11	-	msec	Note 3
	$T_{OFF}$		-	9	-	msec	Note 3
Contrast ratio	CR		800	1000	-	-	Note 4
Color chromaticity	$W_X$		0.270	0.0290	0.350		Note 2 Note 5
	$W_Y$		0.280	0.0300	0.360		Note 6
Luminance	L		-	1000	-	cd/m <sup>2</sup>	Note 6
Luminance uniformity	$Y_U$		70	75	-	%	Note 7

Note 1: Definition of viewing angle range

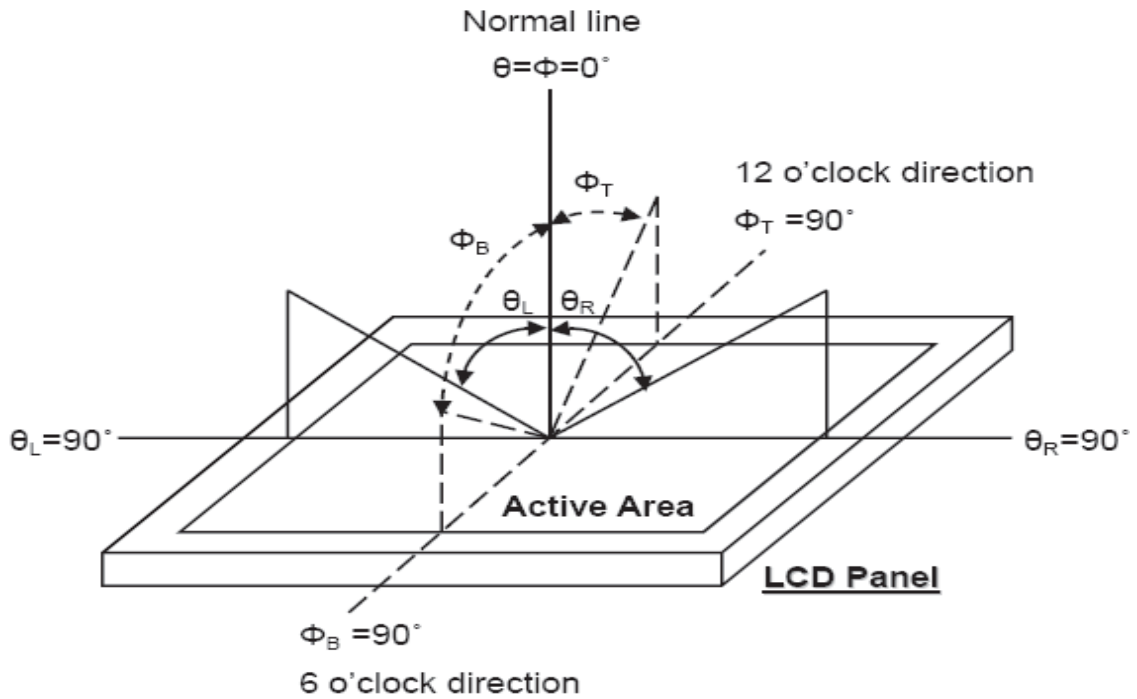

Fig. 7-1 Definition of viewing angle

Note 2: Test equipment setup:

After stabilizing and leaving the panel alone at a driven temperature for 10 minutes, the measurement should be executed. Measurement should be executed in a stable, windless, and dark room. Optical specifications are measured by Topcon BM-7 luminance meter 1.0° field of view at a distance of 50cm and normal direction.

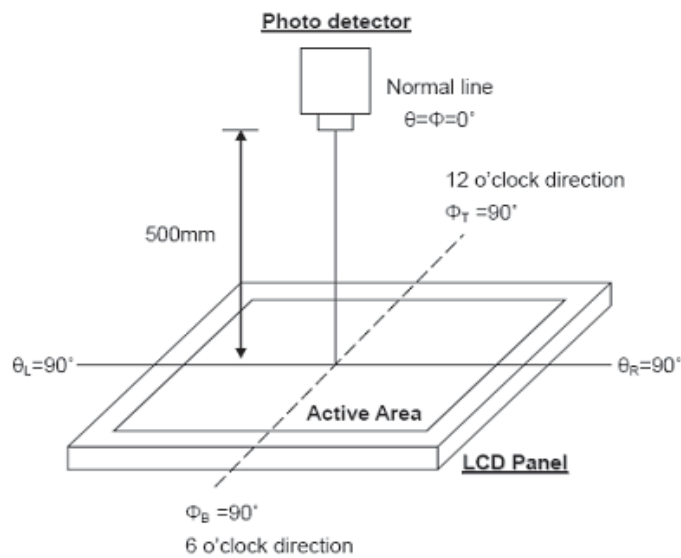

Fig.7-2 Optical measurement system setup

Note 3: Definition of Response time:

The response time is defined as the LCD optical switching time interval between “White state and “Black” state. Rise time,  $T_r$ , is the time between photo detector output intensity changed from 90% to 10% . And fall time,  $T_f$ , is the time between photo detector output Intensity changed from 10% to 90% .

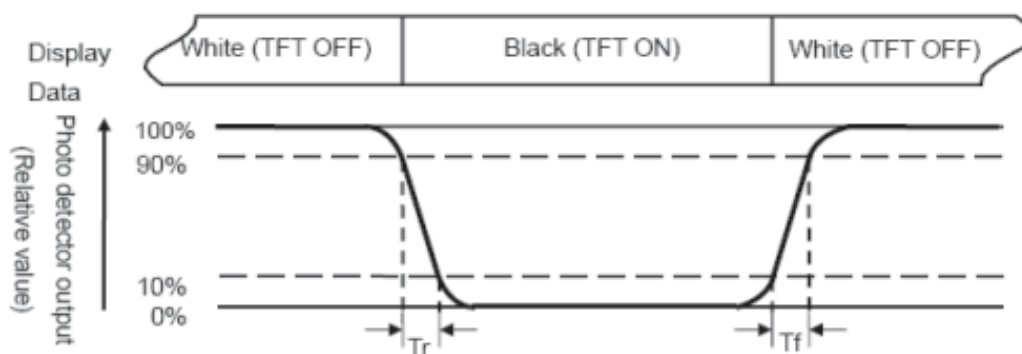

Fig. 3-3 Definition of response time

Note 4: Definition of contrast ratio:

The contrast ratio is defined as the following expression.

$$\text{Contrast ratio (CR)} = \frac{\text{Luminance measured when LCD on the "White" state}}{\text{Luminance measured when LCD on the "Black" state}}$$

Note 5: White  $V_i = V_{i50} \pm 1.5V$

Black  $V_i = V_{i50} \pm 2.0V$

“±” means that the analog input signal swings in phase with VCOM signal.

“±” means that the analog input signal swings out of phase with VCOM signal.

The 100% transmission is defined as the transmission of LCD panel when all the input terminals of module are electrically opened.

Note 6: Definition of color chromaticity (CIE 1931)

Color coordinates measured at the center point of LCD

Note 7: Measured at the center area of the panel when all the input terminals of LCD panel are electrically opened.

$$\text{Note 8 : Uniformity (U)} = \frac{\text{Brightness (min)}}{\text{Brightness (max)}} \times 100\%$$



# 6. Mechanical Drawing

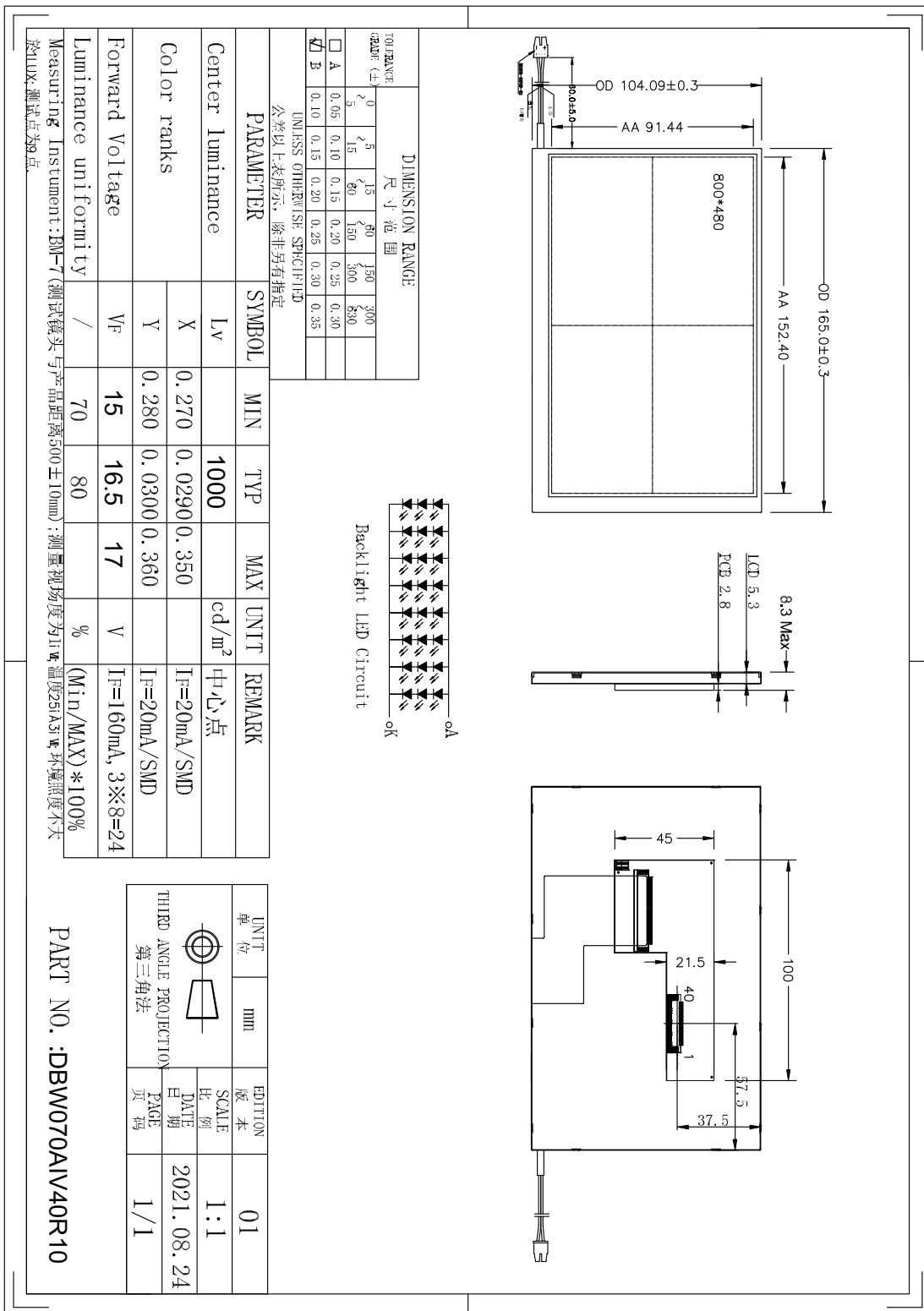

# 7. Package Drawing

## 7"模组纸箱外形成套包材包装示意

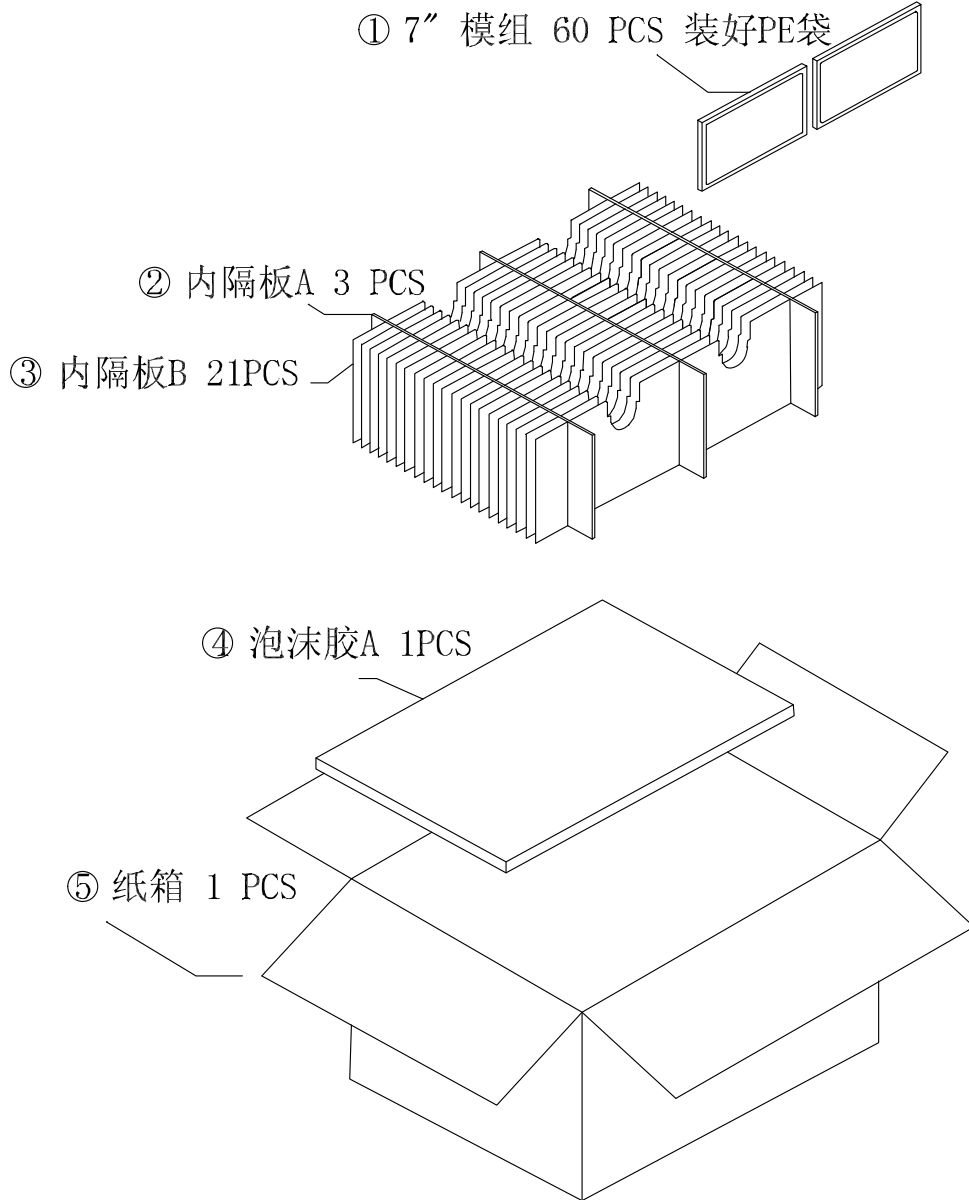



备注:

1. 必须正确填写<外箱标签>中的内容
2. 必须认真检查是否有少装、多装、错装等现象
3. 必须认真检查有无漏贴标签
4. 每箱装60PCS。

序号	日期	修改内容	修订者
包装方式示意图			
模组号		版本	01
客户代码		日期	
			核准 检查 设计

## 8 .Visuals Specification: 1)Note

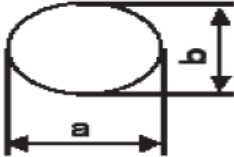
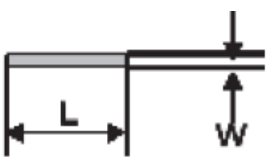
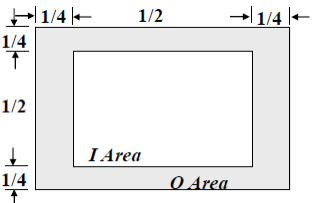
<p><b>General</b></p>	<p>1. Customer identified anomalies not defined within this inspection standard shall be reviewed by Duobond, and an additional standard shall be determined by mutual consent.</p> <p>2. This inspection standard about the image quality shall be applied to any defect within the effective viewing area and shall not be applicable to outside of the area.</p> <p>3. Inspection conditions</p> <p>Luminance : 500 Lux min.</p> <p>Inspection distance : 300 mm.</p> <p>Temperature : 25±5°C</p> <p>Direction : Directly above</p>		
<p><b>Definition of inspection item</b></p>	<p><b>Dot defect</b></p>	<p><b>Bright dot defect</b></p>	<p>The dot is constantly “on” when power applied to the LCD, even when all “Black” data sent to the screen. Inspection tool: 5% Transparency neutral density filter.Count dot: If the dot is visible through the filter. Don’t count dot: If the dot is not visible through the filter.</p>  <p style="text-align: right;">■ dot defect</p>
		<p><b>Black dot defect</b></p>	<p>The dot is constantly “off” when power applied to the LCD, even when all “White” data sent to the screen.</p>
		<p><b>Adjacent dot</b></p>	<p>Adjacent dot defect is defined as two or more bright dot defects or black dot defects.</p>  <p style="text-align: right;">■ dot defect</p>
<p><b>External inspection</b></p>	<p><b>Bubble ,scratch(foreign Particle polarizer, Cell, Backlight)</b></p>		<p>Visible operating (all pixels “Black” or “White”) and non operating.</p>
	<p><b>Appearance inspection</b></p>	<p>Does not satisfy the value at the spec.</p>	
<p><b>Others</b></p>	<p><b>LED wires</b></p>	<p>Damaged to the LED wires, connector, pin, functional failure or appearance failure.</p>	
<p><b>Definition of Size</b></p>	<p><b>Definition of circle :</b>  <math>d = (a + b) / 2</math></p> <p><b>definition of linear size</b> </p> <p><b>definition Area I/O</b> </p>		

## 2) Standard

Classification		Inspection item		Judgment Standard		
Defect (in LCD glass)	Dot defect	Area		I	O	
		Bright dots(Note: Visible under:ND5%) 1:D≤0.15mm:No count); D>0.15mm acceptable: 2		N≤0	N≤2	
		Dark dots (0.15mm<D≤0.3mm), D>0.3mm Not allowable		N≤3		
		Bright dot-2Adjacent		N≤0		
		Dark dot-2Adjacent		N≤0		
		Dark or bright dots-3 and more adjacent(note6)		N≤0		
		Total bright and dark dots		N≤5		
		Minimum distance between bright dots		5mm		
		Minimum distance between dark dots		5mm		
		Minimum distance between bright and bright dots		5mm		
	Other	White dot ,dark dot (circle)	Size (mm)		Acceptable number	
			d≤0.2		Neglected	
			0.2mm<D≤0.3mm		N≤4	
			0.3mm<D≤0.4mm		N≤2	
D>0.4mm			Not allowable			
Visual defect	Foreign partial	Circular foreign material: dark/bright sport		Visible under:ND5% 1:D≤0.15mm:No count 2:0.15mm<D≤0.3mm,N≤4 3:D>0.3mm:Not allowable		
		Linear foreign material: bright or dark line		Invisible under ND5% 0.1mm<W≤0.3mm, 0.3mm<L≤1.5mm,N≤4 Visible under ND5% 0.05mm≤w≤0.1mm, 0.3mm≤L≤0.7mm,N≤4		
	Polarizer	Linear scratch		1:BM:No Count 2:Pixel area 0.05mm≤w≤0.2mm, 1.0mm≤L≤5.0mm,N≤4		
		Bubble peeling		1:BM:No Count 2:Pixel area 0.15mm≤D<0.3mm,N≤4		
	Mura & leak		ND5%			

## **9.0 GENERAL PRECAUTION**

### **9.1 Use Restriction**

This product is not authorized for use in life supporting systems, aircraft navigation control systems, military systems and any other application where performance failure could be life threatening or otherwise catastrophic.

### **9.2 Disassembling or Modification**

Do not disassemble or modify the module. It may damage sensitive parts inside LCD module, and may cause scratches or dust on the display. AUO does not warrant the module, if customers disassemble or modify the module.

### **9.3 Breakage of LCD Panel**

9.3.1. If LCD panel is broken and liquid crystal spills out, do not ingest or inhale liquid crystal, and do not contact liquid crystal with skin.

9.3.2. If liquid crystal contacts mouth or eyes, rinse out with water immediately.

9.3.3. If liquid crystal contacts skin or cloths, wash it off immediately with alcohol and rinse thoroughly with water.

9.3.4. Handle carefully with chips of glass that may cause injury, when the glass is broken.

### **9.4 Electric Shock**

9.4.1. Disconnect power supply before handling LCD module.

9.4.2. Do not pull or fold the LED cable.

9.4.3. Do not touch the parts inside LCD modules and the fluorescent LED's connector or cables in order to prevent electric shock.

### **9.5 Absolute Maximum Ratings and Power Protection Circuit**

9.5.1. Do not exceed the absolute maximum rating values, such as the supply voltage variation, input voltage variation, variation in parts' parameters, environmental temperature, etc., otherwise LCD module may be damaged. 9.5.2. Please do not leave LCD module in the environment of high humidity and high temperature for a long time. 11.5.3. It's recommended to employ protection circuit for power supply.

### **9.6 Operation**

9.6.1 Do not touch, push or rub the polarizer with anything harder than HB pencil lead.

9.6.2 Use fingerstalls of soft gloves in order to keep clean display quality, when persons handle the LCD module for incoming inspection or assembly.

**9.6.3** When the surface is dusty, please wipe gently with absorbent cotton or other soft material.

**9.6.4** Wipe off saliva or water drops as soon as possible. If saliva or water drops contact with polarizer for a long time, they may causes deformation or color fading.

**9.6.5** When cleaning the adhesives, please use absorbent cotton wetted with a little petroleum benzine or other adequate solvent.

## **9.7 Mechanism**

Please mount LCD module by using mouting holes arranged in four corners tightly.

## **9.8 Static Electricity**

**9.8.1** Protection film must remove very slowly from the surface of LCD module to prevent from electrostatic occurrence.

**9.8.2.** Because LCD module use CMOS-IC on circuit board and TFT-LCD panel, it is very weak to electrostatic discharge. Please be careful with electrostatic discharge. Persons who handle the module should be grounded through adequate methods.

## **9.9 Strong Light Exposure**

The module shall not be exposed under strong light such as direct sunlight. Otherwise, display characteristics may be changed.

## **9.10 Disposal**

When disposing LCD module, obey the local environmental regulations.