



PRODUCT SPECIFICATION

CDTECH Model: **S050BWV119NN**

CUSTOMER Model: **-**

Description: **5.0 " TFT-LCD Module**

Version: **1.0**

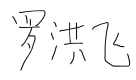
CDTECH	PREPARED BY	CHECKED BY	APPROVED BY
SIGNATURE			
DATE	2024.3.19	2024.3.19	2024.3.19

CUSTOMER APPROVAL	SIGNATURE	DATE



Contents

1. General Specifications	4
2. Absolute Maximum Ratings	4
3. Electrical Characteristics	5
4. Interface Pin Assignment	6
5. Interface Characteristics	7
6. Optical Specifications	14
7. Reliability Test Items	18
8. Mechanical Drawing	19
9. Packing	20
10. Precautions for Use of LCD modules	21

1. General Specifications

1.1 LCM General Information

Item	Specification	Unit
LCD Size	5.0	inch
Number of Pixels	480 (H) RGB x 854 (V)	pixels
Display Mode	Normally Black	-
Viewing Direction	Free	o' clock
Interface	RGB	-
Display Colors	16.7M	colors
Outline Dimension	66.4 (H) x 120.05 (V) x 2.05 (D)	mm
Active Area	61.56 (H) x 109.53 (V)	mm
Pixel Pitch	0.1282 (H) x 0.1282 (V)	mm
Driver IC	ST7701S	-
Operation Temperature	-20~70	°C
Storage Temperature	-30~80	°C

Note1:Requirements on environmental protection RoHS compliant.

2. Absolute Maximum Ratings

Item	Symbol	MIN.	MAX.	Unit	Note
Analog Supply voltage	VDD	-0.3	5.0	V	Note 1

Note 1:Permanent damage may occur to the LCD module if beyond this specification.

Functional operation should be restricted to the conditions described under normal operating conditions.

3. Electrical Characteristics

3.1 Recommended Operating Condition for TFT LCD

Item	Symbol	Min.	Typ.	Max.	Unit	Note
Analog Supply voltage	VDD	3.0	3.3	3.6	V	
Analog supply current	I _{VDD}	-	TBD	-	mA	VDD=3.3V
Logic input voltage	V _{IH}	0.7*VDD	-	VDD	V	
	V _{IL}	GND	-	0.3*VDD	V	

3.2 Recommended Driving Condition for Backlight

Item	Symbol	Min.	Typ.	Max.	Unit	Note
Driving Current	I _F	-	40	-	mA	
Driving Voltage	V _F	16.2	-	20.4	V	
Power consumption	W _{BL}	0.648	-	0.816	W	
LED Life-Time	N/A	-	50,000	-	Hours	Ta=25°C Note 1

Note 1:LED lifetime is defined as the module brightness decay 50% of original brightness at Ta=25 degree, typical current.

Note 2:LED circuit :

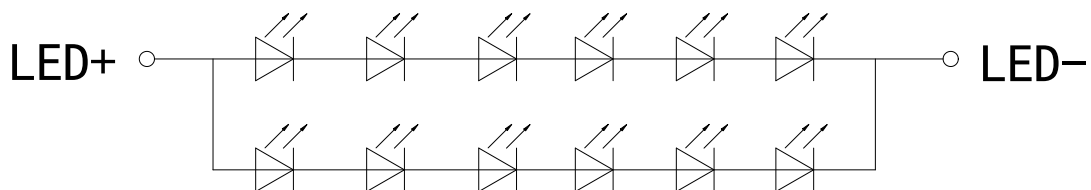

4. Interface Pin Assignment

4.1 LCM Pin Assignment

No.	Symbol	Description
1	NC	No connection
2	YU(NC)	No connection
3	XL(NC)	No connection
4	YD(NC)	No connection
5	XR(NC)	No connection
6	CS	Chip select input signal
7	SCL	Serial clock signal
8	SDA	Serial data input/output signal
9	RESET	Global reset pin
10	GND	Ground
11	NC	No connection
12	DE	Data enable input. Active high to enable the input data bus under “DE Mode”
13	VS	Vertical sync input. Negative polarity
14	HS	Horizontal sync input. Negative polarity
15	NC	No connection
16	PCLK	Dot clock signal input. Latching input data at its rising edge
17	GND	Ground
18-25	B7-B0	Data bus
26-33	G7-G0	Data bus
34-41	R7-R0	Data bus
42	VDD	Power supply
43	GND	Ground
44	LED+A	Power for LED backlight (Anode)
45	LED-K	Power for LED backlight (Cathode)

5. Interface Characteristics

5.1 POWER ON/OFF SEQUENCE

The power on/off sequence is illustrated below

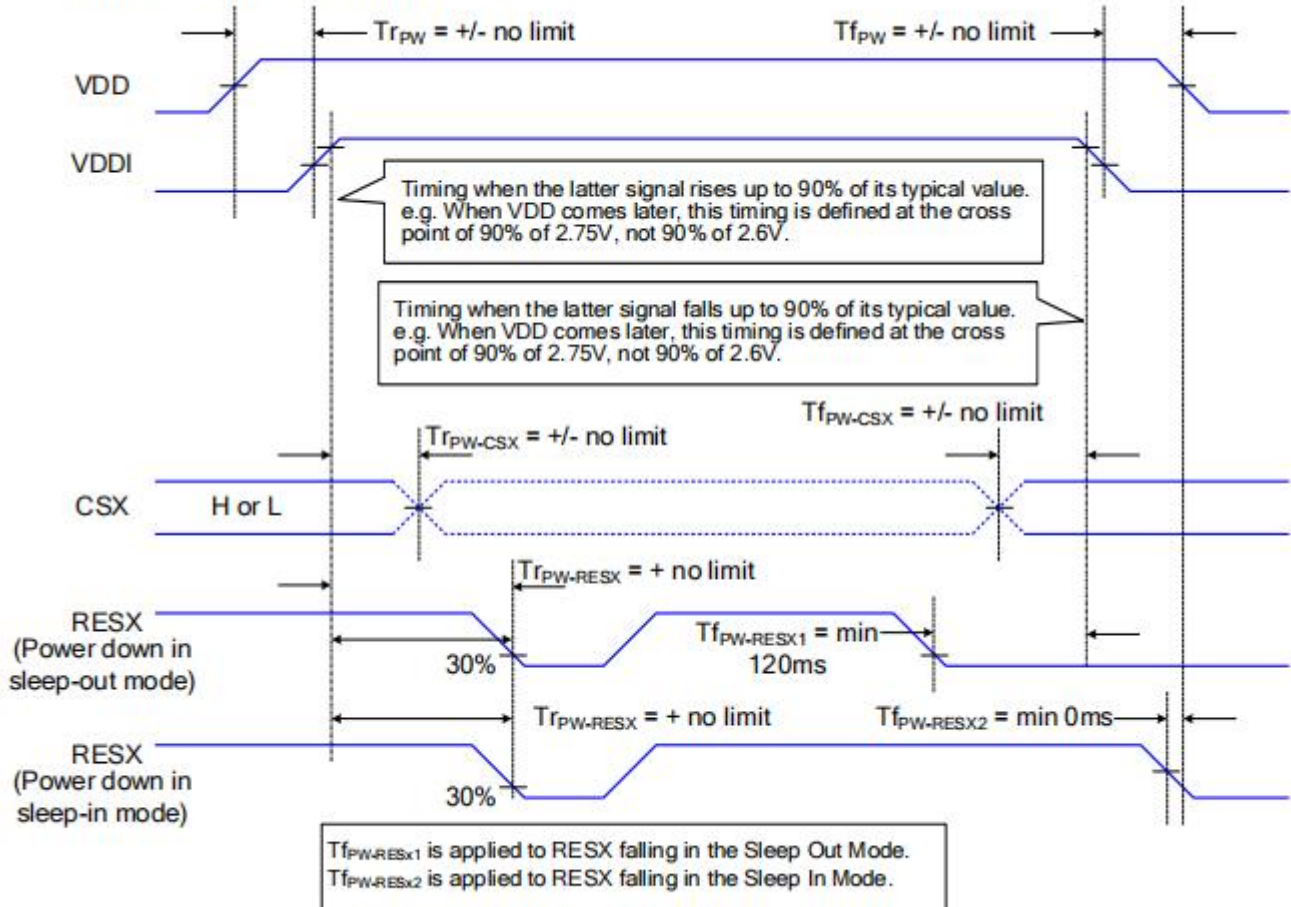

5.2 AC Characteristics

Serial Interface Characteristics (3-line serial):

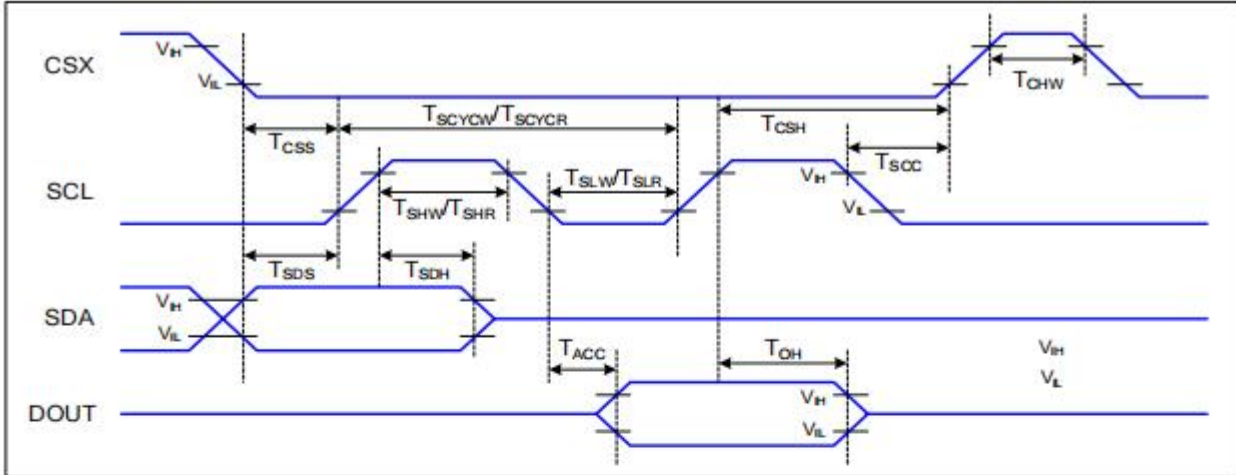

Figure 1 3-line serial Interface Timing Characteristics

VDDI=1.8, VDD=2.8, AGND=DGND=0V, Ta=25°C

Signal	Symbol	Parameter	Min	Max	Unit	Description
CSX	T _{CSS}	Chip select setup time (write)	15		ns	
	T _{Csh}	Chip select hold time (write)	15		ns	
	T _{CSS}	Chip select setup time (read)	60		ns	
	T _{SCC}	Chip select hold time (read)	60		ns	
	T _{CHW}	Chip select "H" pulse width	40		ns	
SCL	T _{SCYCW}	Serial clock cycle (Write)	66		ns	
	T _{SHW}	SCL "H" pulse width (Write)	15		ns	
	T _{SLW}	SCL "L" pulse width (Write)	15		ns	
	T _{SCYCR}	Serial clock cycle (Read)	150		ns	
	T _{SHR}	SCL "H" pulse width (Read)	60		ns	
	T _{SLR}	SCL "L" pulse width (Read)	60		ns	
SDA (DIN)	T _{SDS}	Data setup time	10		ns	
	T _{SDH}	Data hold time	10		ns	

Table 4 3-line serial Interface Characteristics

Note : The rising time and falling time (Tr, Tf) of input signal are specified at 15 ns or less. Logic high and low levels are specified as 30% and 70% of VDDI for Input signals.

Serial Interface Characteristics (4-line serial):

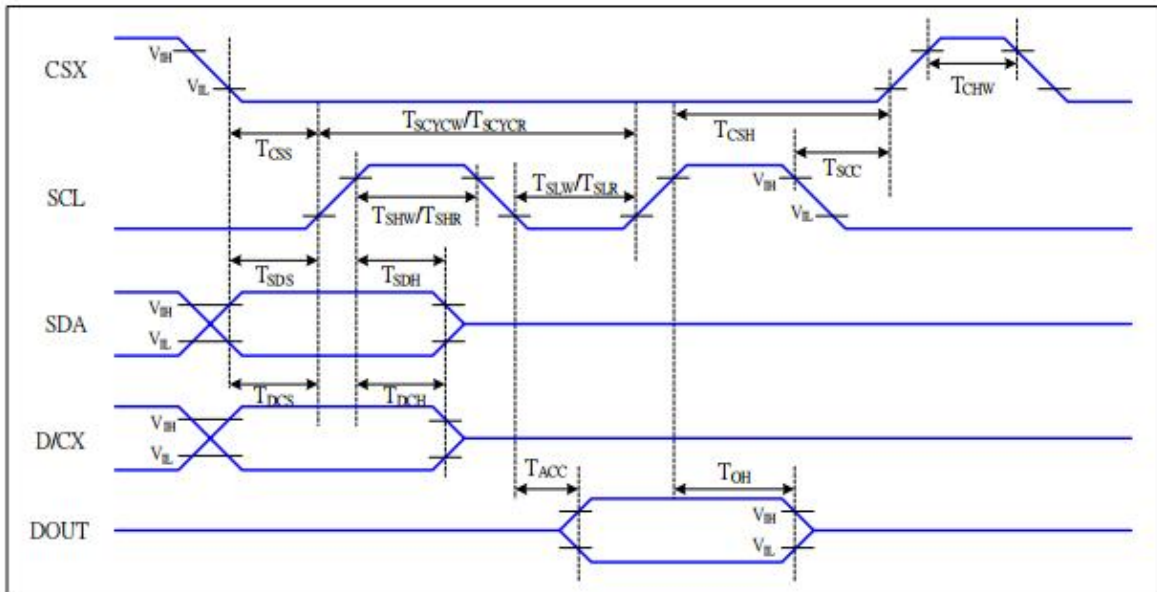

Figure 2 4-line serial Interface Timing Characteristics

VDDI=1.8, VDD=2.8, AGND=DGND=0V, Ta=25 °C

Signal	Symbol	Parameter	MIN	MAX	Unit	Description
CSX	T _{CSS}	Chip select setup time (write)	15		ns	
	T _{CSSH}	Chip select hold time (write)	15		ns	
	T _{CSS}	Chip select setup time (read)	60		ns	
	T _{SCC}	Chip select hold time (read)	65		ns	
	T _{CHW}	Chip select "H" pulse width	40		ns	
SCL	T _{SCYCW}	Serial clock cycle (Write)	66		ns	-write command & data ram
	T _{SHW}	SCL "H" pulse width (Write)	15		ns	
	T _{SLW}	SCL "L" pulse width (Write)	15		ns	
	T _{SCYCR}	Serial clock cycle (Read)	150		ns	-read command & data ram
	T _{SHR}	SCL "H" pulse width (Read)	60		ns	
	T _{SLR}	SCL "L" pulse width (Read)	60		ns	
D/CX	T _{DCS}	D/CX setup time	10		ns	
	T _{DCH}	D/CX hold time	10		ns	
SDA (DIN)	T _{SDS}	Data setup time	10		ns	
	T _{SDH}	Data hold time	10		ns	

Table 5 4-line serial Interface Characteristics

RGB Interface Characteristics :

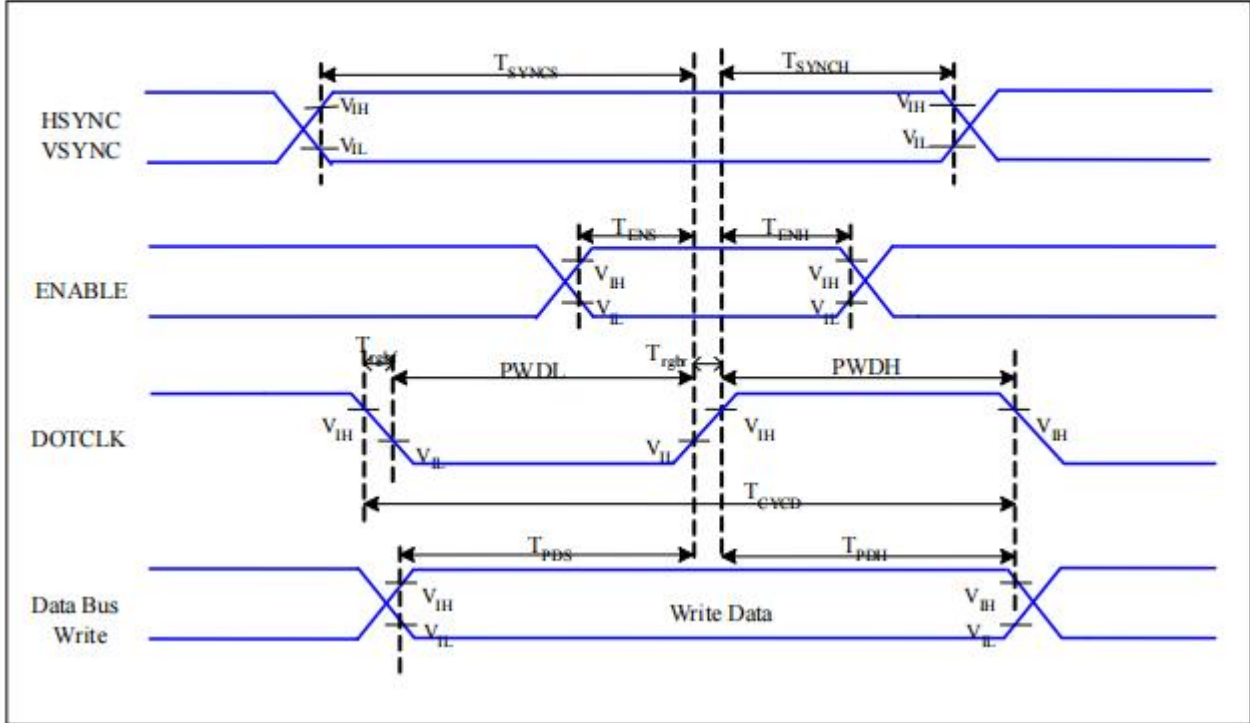

Figure 3 RGB Interface Timing Characteristics

$VDDI=1.8, VDD=2.8, AGND=DGND=0V, Ta=25\text{ }^{\circ}\text{C}$

Signal	Symbol	Parameter	MIN	MAX	Unit	Description
HSYNC, VSYNC	T_{SYNCS}	VSYNC, HSYNC Setup Time	5	-	ns	
ENABLE	T_{ENS}	Enable Setup Time	5	-	ns	
	T_{ENH}	Enable Hold Time	5	-	ns	
DOTCLK	PWDH	DOTCLK High-level Pulse Width	15	-	ns	
	PWDL	DOTCLK Low-level Pulse Width	15	-	ns	
	T_{cycD}	DOTCLK Cycle Time	33	-	ns	
	Trghr, Trghf	DOTCLK Rise/Fall time	-	15	ns	
DB	T_{PDS}	PD Data Setup Time	5	-	ns	
	T_{PDH}	PD Data Hold Time	5	-	ns	

Table 6 18/16 Bits RGB Interface Timing Characteristics

Reset Timing:

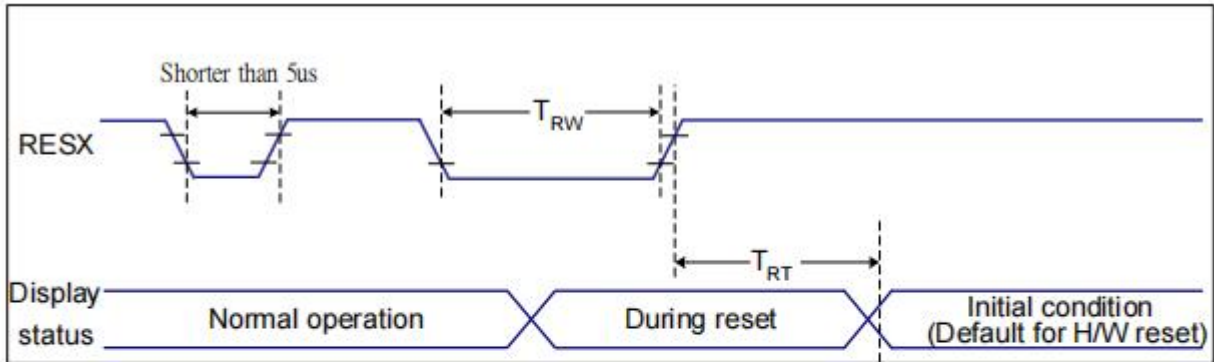

Figure 9 Reset Timing

$V_{DD1}=1.8, V_{DD}=2.8, A_{GND}=D_{GND}=0V, T_a=25\text{ }^{\circ}\text{C}$

Related Pins	Symbol	Parameter	MIN	MAX	Unit
RESX	TRW	Reset pulse duration	10	-	us
	TRT	Reset cancel	-	5 (Note 1, 5)	ms
			120 (Note 1, 6, 7)	ms	

Table 9 Reset Timing

5.3 RGB Interface Timing

The timing chart of RGB interface DE mode is shown as follows.

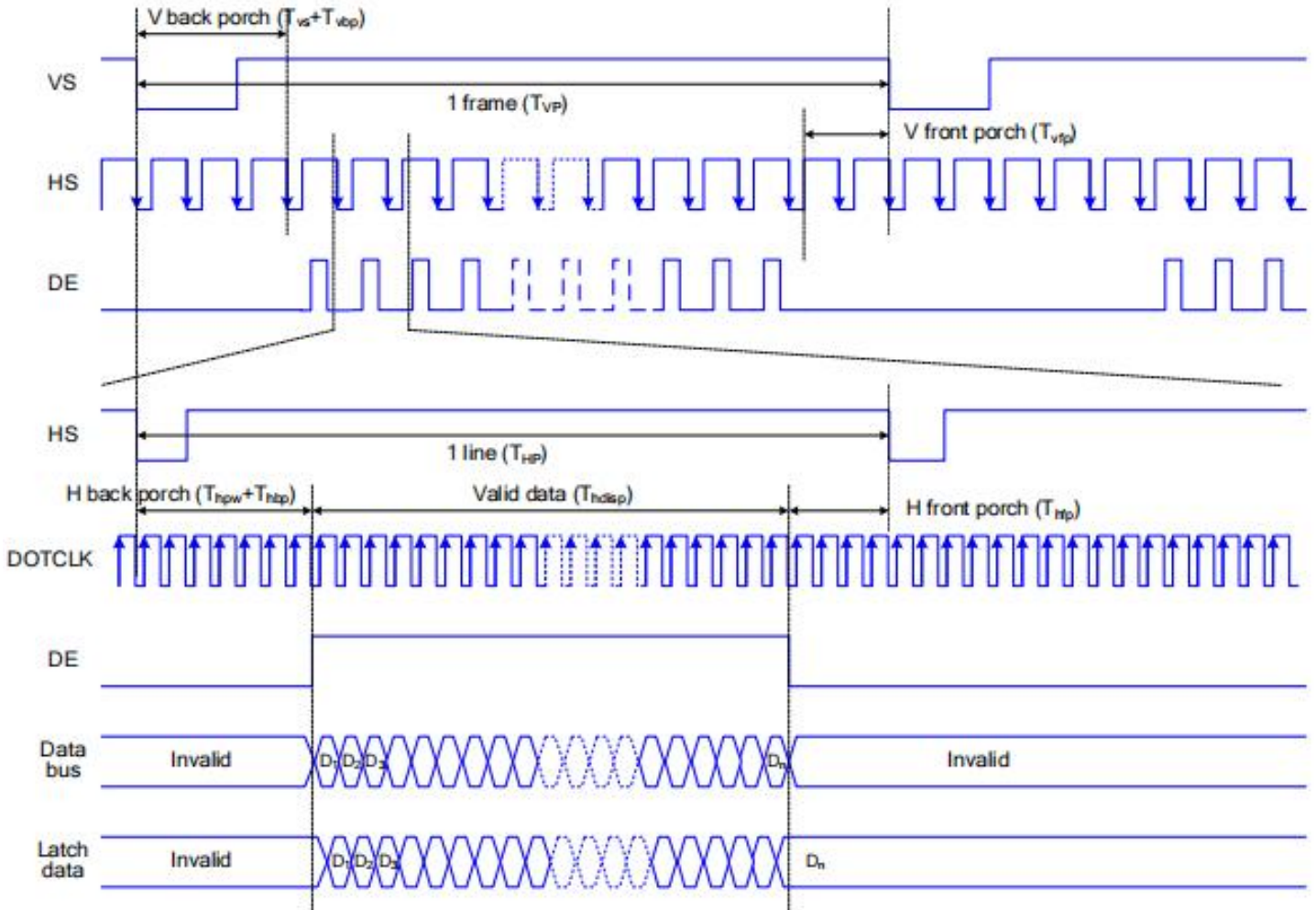

Note: The setting of front porch and back porch in host must match that in IC as this mode.

Figure 23 Timing Chart of Signals in RGB Interface DE Mode

The timing chart of RGB interface HV mode is shown as follows.

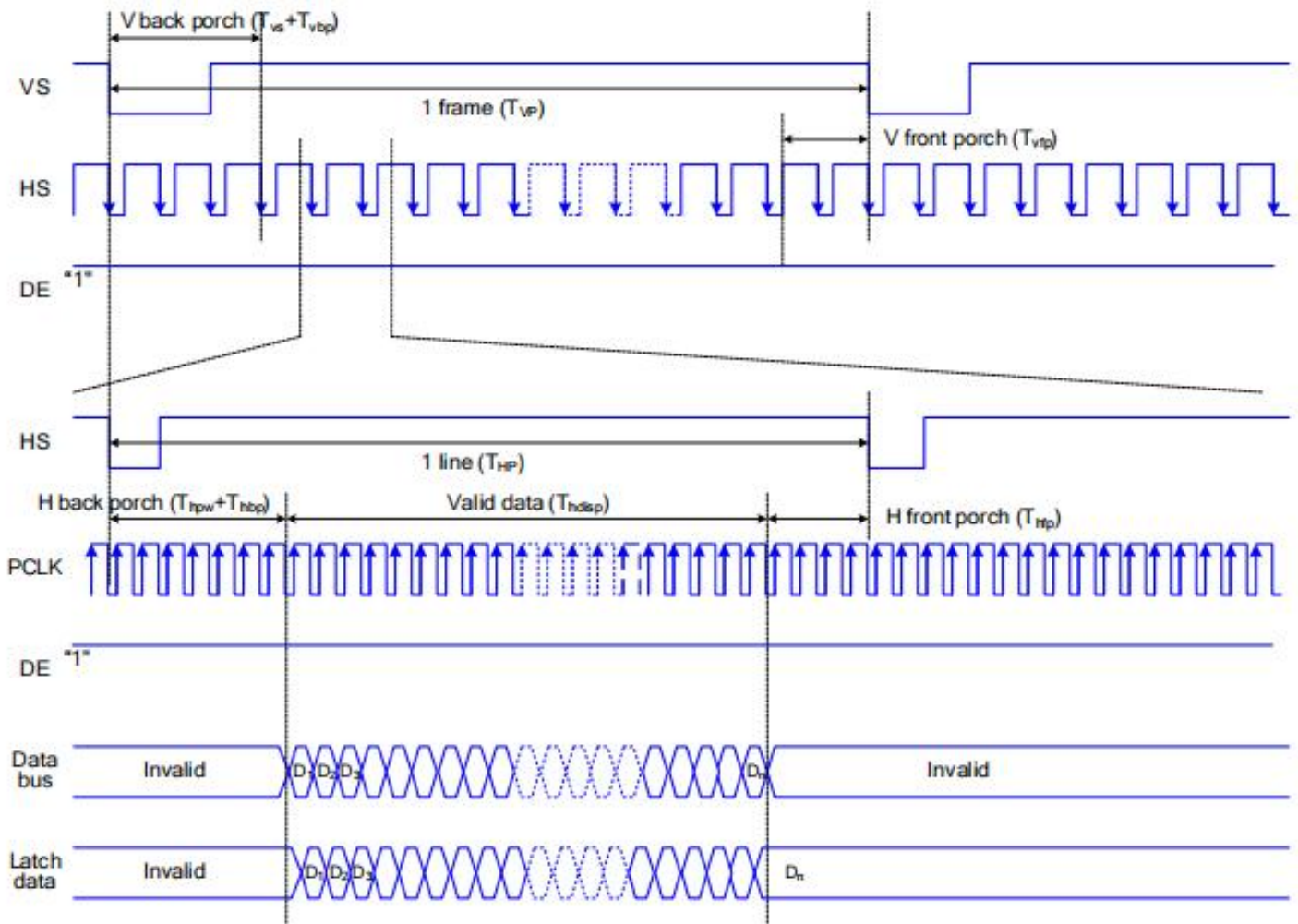

Figure 24 Timing chart of RGB interface HV mod

6. Optical Specifications

Item	Symbol	Condition	Min.	Typ.	Max.	Unit	Note
Viewing Angle (CR≥10) B/L ON	θ_T	$\Phi=90^\circ$ (12 o'clock)	-	80	85	deg	Note2
	θ_B	$\Phi=270^\circ$ (6 o'clock)	-	80	85	deg	Note2
	θ_L	$\Phi=180^\circ$ (9 o'clock)	-	80	85	deg	Note2
	θ_R	$\Phi=0^\circ$ (3 o'clock)	-	80	85	deg	Note2
Response Time	T_{ON}	Normal $\theta=\Phi=0^\circ$	-	15	17	msec	Note4
	T_{OFF}		-	15	17	msec	Note4
Contrast Ratio	CR		600	800	-	-	Note1 Note3
Color Chromaticity	W_X		0.275	0.305	0.335	-	Note1 Note5
	W_Y		0.286	0.316	0.346	-	Note1 Note5
Luminance	L		320	400	-	cd/m ²	Note1 Note7
Luminance Uniformity	Y_U		75	80	-	%	Note1 Note6
NTSC	-		-	67.3	-	%	-

Note 1: Definition of optical measurement system

The optical characteristics should be measured in dark room. After 5 minutes operation, the optical properties are measured at the center point of the LCD screen. All input terminals LCD panel must be ground when measuring the center area of the panel.

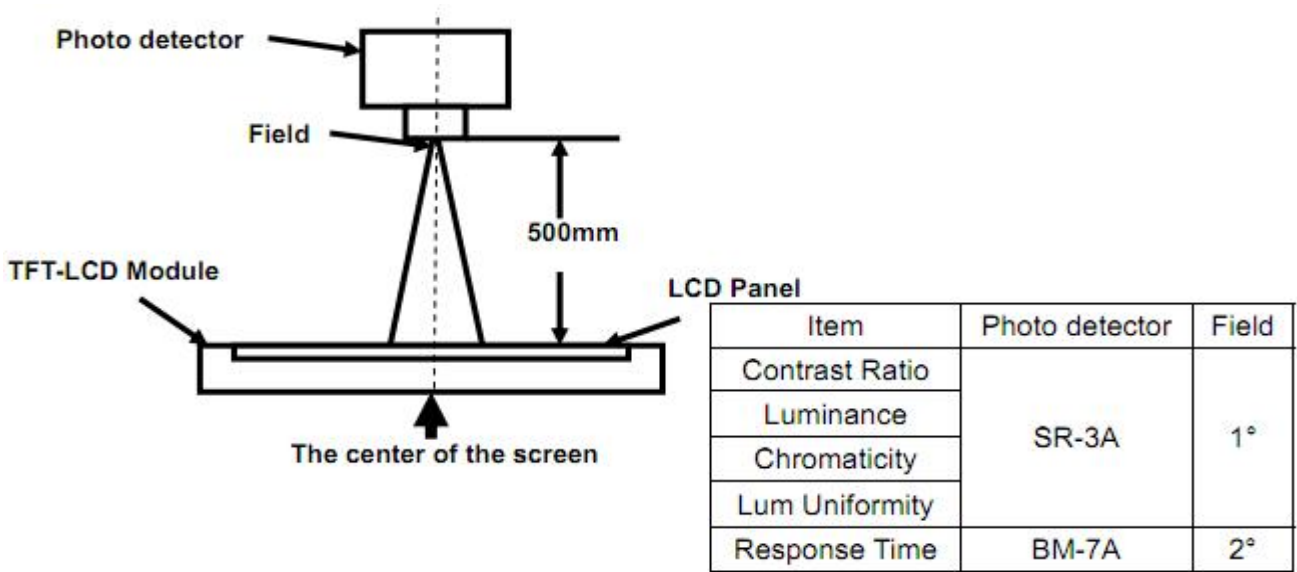

Fig 1

Note 2: Definition of viewing angle range and measurement system.

viewing angle is measured at the center point of the LCD by CONOSCOPE(ergo-80).

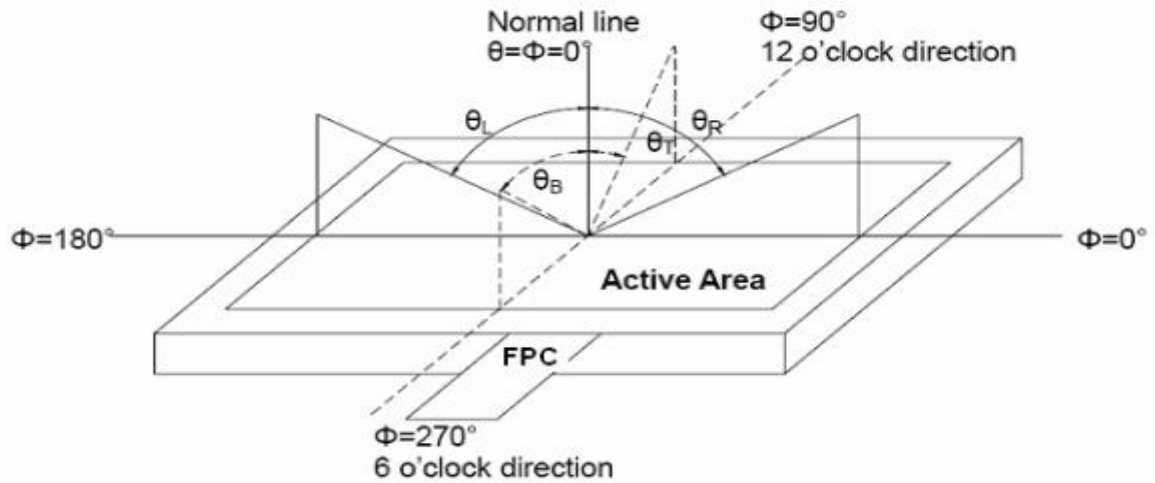

Fig 2 Definition of viewing angle

Note 3: Definition of contrast ratio

$$CR = \frac{\text{Luminance with all pixels white}}{\text{Luminance with all pixels black}}$$

Note 4: Definition of Response time

The response time is defined as the LCD optical switching time interval between “White” state and “Black” state. Rise time (TON) is the time between photo detector output intensity changed from 90% to 10%. And fall time (TOFF) is the time between photo detector output intensity changed from 10% to 90%.

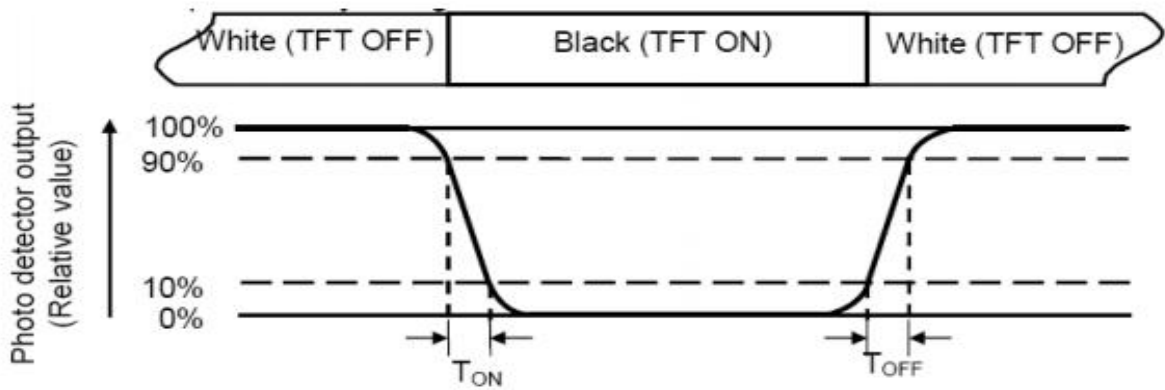

Note 5: Definition of color chromaticity (CIE1931)

Color coordinates measured at center point of LCD.

Note 6: Definition of Luminance Uniformity

The luminance uniformity in surface luminance is determined by measuring luminance at each test position 1 through n, and then dividing the maximum luminance of n points luminance by minimum luminance of n points luminance. For more information see FIG.3-a/b

Note 7: Surface luminance is the luminance with all pixels displaying white.

L_v = Average Surface Luminance with all white pixels (P1, P2, P3, ..., Pn)

For more information see FIG.3-a/b

Note 8: Size : $S \leq 5"$ (see Figure a) A : 5 mm B : 5 mm. H, V : Active area

Light spot size $\varnothing = 5\text{mm}$ (BM-5) or $\varnothing = 7.7\text{mm}$ (BM-7) 50cm distance or test spot position : see Figure a.

measurement instrument : TOPCON's luminance meter SR-3A or BM-7 or compatible (see Figure 1).

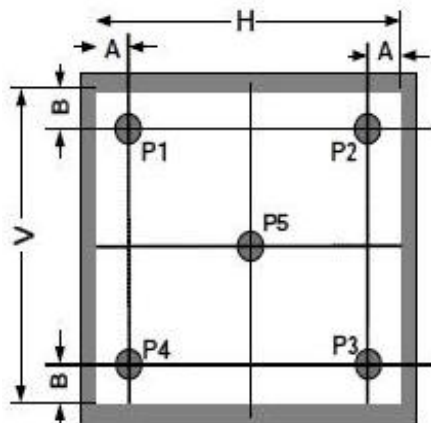

Fig. 3-a Definition of points

$5'' < S \leq 12.3''$ (see Figure b) . H,V : Active area

Light spot size $\varnothing = 5\text{mm}$ (BM-5) or $\varnothing = 7.7\text{mm}$ (BM-7) 50cm distance or compatible distance from the LCD surface to detector lens. test spot position : see Figure b.

measurement instrument : TOPCON's luminance meter SR-3A or BM-7 or compatible (see Figure 1).

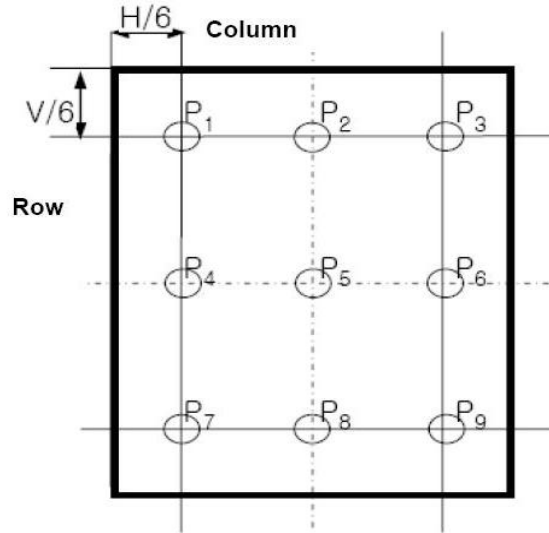

Fig. 3-b Definition of points

7. Reliability Test Items

Test Item	Test Conditions
High Temperature Storage	Ta= +80°C 96hrs
Low Temperature Storage	Ta= -30°C 96hrs
High Temperature Operation	Ta= +70°C 96hrs
Low Temperature Operation	Ta= -20°C 96hrs
High Temperature and Humidity Storage	Ta= +60°C, 90% RH 96hrs
Thermal Shock (Non-operation)	-30°C/30 min ~ +80°C/30 min for 20 cycles Start with cold temperature end with high temperature
Electro Static Discharge	Contact = ± 4 kV, class B Air = ± 8 kV, class B R=330Ω,C=150pF
Vibration	Sweep: 10Hz~55Hz~10Hz Stroke: 1.5mm 2 hrs for each direction of X .Y. Z.
Mechanical Shock	60G 6ms,±X,±Y,±Z 3 times for each direction
Package Drop Test	Height: 60 cm 1 corner, 3 edges, 6 surfaces

Notes: The test result shall be evaluated after the sample has been left at room temperature and humidity for 2 hours without load. No condensation shall be accepted. The sample will not be accepted if appear these defects:

- 1). Air bubble in the LCD
- 2). Seal leak or Glass crack
- 3). Non display or abnormal display
- 4). Brightness reduction >50%

8. Mechanical Drawing

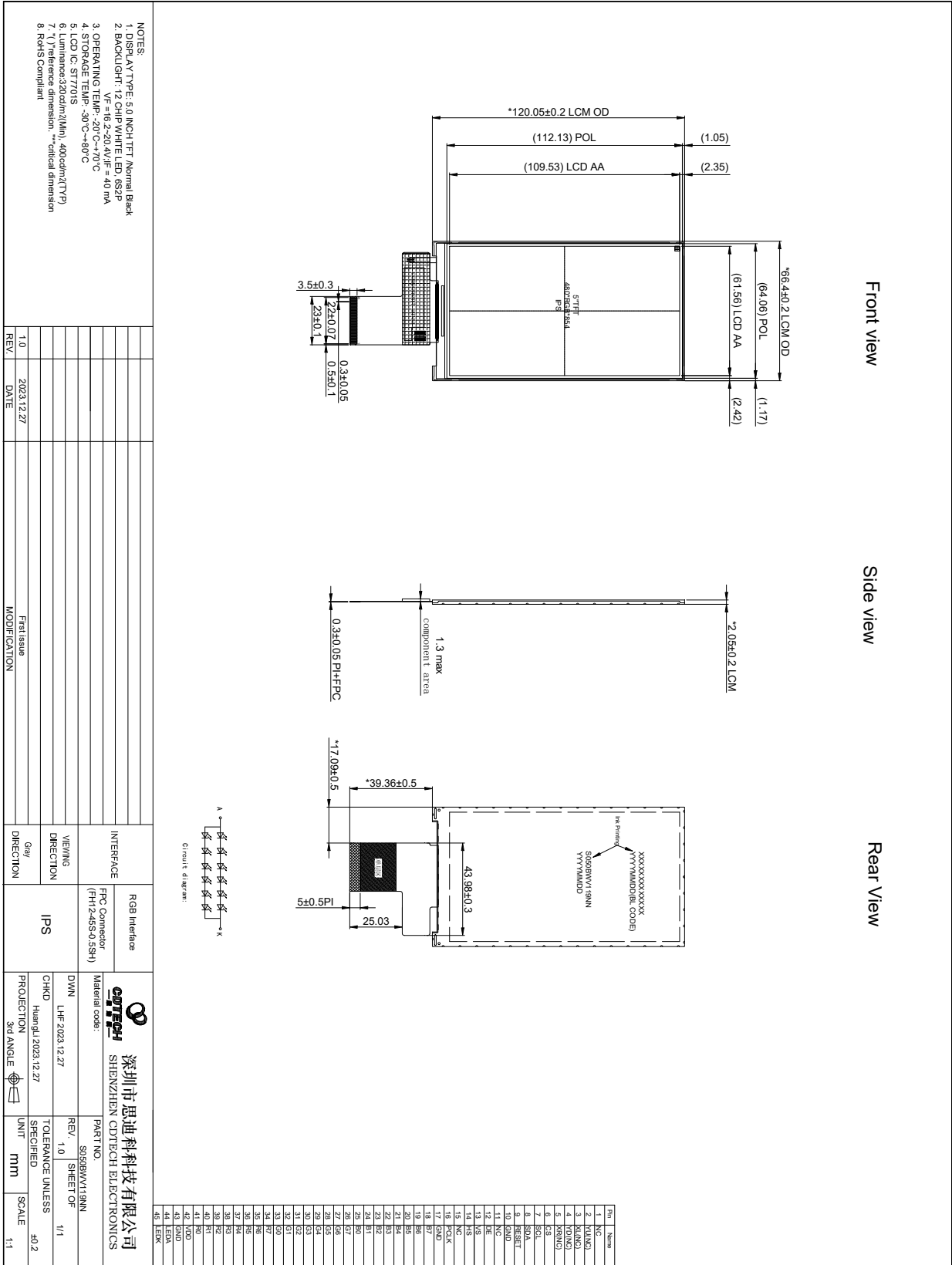

9. Packing

Packing Method

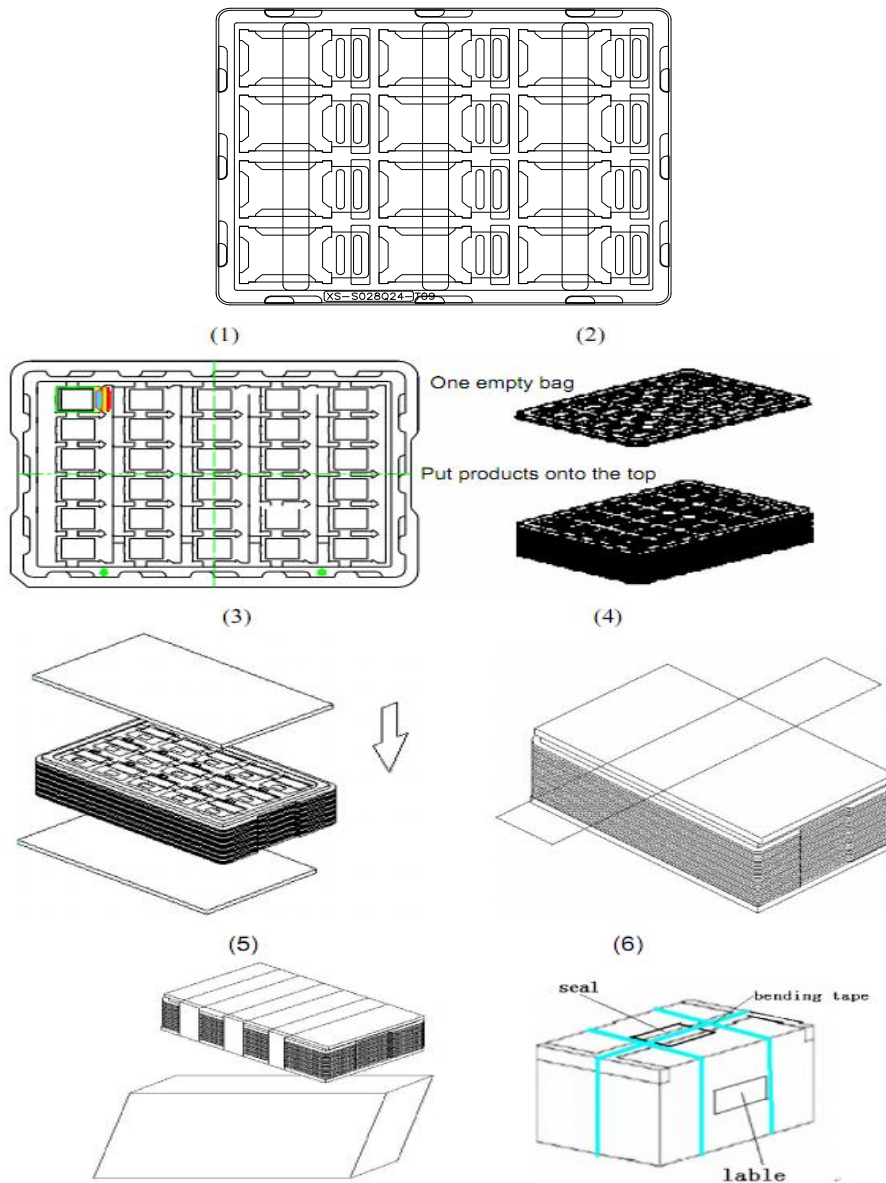

Steps:

1. Put module into tray cavity
2. Tray stacking
3. Put 1 cardboard under the tray stack and 1 cardboard above
4. Fix the cardboard to the tray stack with adhesive tape
5. Put the tray stack into carton
6. Carton sealing with adhesive tape

10. Precautions for Use of LCD modules

10.1 Handling Precautions

10.1.1. The display panel is made of glass. Do not subject it to a mechanical shock by dropping it from a high place, etc.

10.1.2. If the display panel is damaged and the liquid crystal substance inside it leaks out, be sure not to get any in your mouth, if the substance comes into contact with your skin or clothes, promptly wash it off using soap and water.

10.1.3. Do not apply excessive force to the display surface or the adjoining areas since this may cause the color tone to vary.

10.1.4. The polarizer covering the display surface of the LCD module is soft and easily scratched. Handle this polarizer carefully.

10.1.5. If the display surface is contaminated, breathe on the surface and gently wipe it with a soft dry cloth. If still not completely clear, moisten cloth with one of the following solvents:

- Isopropyl alcohol
- Ethyl alcohol

Solvents other than those mentioned above may damage the polarizer. Especially, do not use the following:

- Water
- Ketene
- Aromatic solvents

10.1.6. Do not attempt to disassemble the LCD Module.

10.1.7. If the logic circuit power is off, do not apply the input signals.

10.1.8. To prevent destruction of the elements by static electricity, be careful to maintain an optimum work environment.

10.1.8.1. Be sure to ground the body when handling the LCD Modules.

10.1.8.2. Tools required for assembly, such as soldering irons, must be properly ground.

10.1.8.3. To reduce the amount of static electricity generated, do not conduct assembly and other work under dry conditions.

10.1.8.4. The LCD Module is coated with a film to protect the display surface. Be care when peeling off this protective film since static electricity may be generated.

10.2 Storage Precautions

10.2.1. When storing the LCD modules, avoid exposure to direct sunlight or to the light of fluorescent lamps.

10.2.2. The LCD modules should be stored under the storage temperature range if the LCD modules will be stored for a long time, the recommend condition is :

Temperature : 0°C ~40°C Relatively humidity: ≤80%

10.2.3. The LCD modules should be stored in the room without acid, alkali and harmful gas.

10.3 Transportation Precautions

The LCD modules should be no falling and violent shocking during transportation, and also should avoid excessive press, water, damp and sunshine.