



CDTech(H.K.)Electronics Limited

Product Specification

Model Name	S058HWV04HS
Description	Standard LCD Module 5.8" WVGA 800(RGB)x320 Dots
Date	2019/3/27
Version	1.0

Approved by/Date	Check by/Date	Prepared by/Date
ZHP 2019/3/27	HZX 2019/3/27	Yigui.Han 2019/3/27

Customer Approval	
Date	



CDTech(H.K.)Electronics Limited

Table of Contents

1. Record of Revision.....	3
2. General Specifications.....	4
3. Input/OutputTerminals.....	5
4. Absolute Maximum Rating.....	8
5. Electrical Characteristics.....	8
6. Interface Timing.....	12
7. Optical Characteristics.....	16
8. Environmental / Reliability Tests.....	20
9. Mechanical Drawing.....	21
10. Packing.....	22
11. TFT-LCD Module Inspection Criteria.....	23
12. Precautions for Use of LCD modules.....	28

2. General Specifications

	Feature	Spec
Characteristics	Size	5.8 inch
	Resolution	800(horizontal)*320(Vertical)
	Interface	RGB-24bit
	Connect type	Connector
	Display Colors	16.2M
	Technology type	a-Si
	Pixel pitch (mm)	0.1719 x 0.1607
	Pixel Configuration	R.G.B.-Stripe
	Display Mode	Normally White
	Viewing Direction	12 O'clock
	Gray Inversion Direction	6 O'clock
Mechanical	LCM (W x H x D) (mm)	154.40*63.34*3.5
	Active Area(mm)	137.52 x51.44
	With /Without TSP	Without TSP
	Weight (g)	TBD
	LED Numbers	24 LEDs

Note 1: Requirements on Environmental Protection: RoHs

Note 2: LCM weight tolerance: +/- 5%

3. Input/Output Terminals

LCD PIN-MAP

No.	Symbol	Description
1	AGND	System Ground
2	AVDD	Analog power
3	VCC	Power supply for logic operation
4~11	R0~R7	Data bus
12~19	G0~G7	Data bus
20~27	B0~B7	Data bus
28	DOTCLK	Pixel clock signal
29	DE	Data Enable
30	HSD	Horizontal Sync signal
31	VSD	Vertical Sync signal
32	MODE3	DE/SYNC mode select. Normally pull high H: DE mode. L: HSD/VSD mode
33	RSTB	Global reset pin. Active low to enter reset state. Suggest to connecting with an RC reset circuit for stability. Normally pull high. (R=47K Ω , C=1 μ)
34	STBYB	Standby mode, normally pull high STBYB="1", normal operation STBYB="0", timing control, source driver will turn off, all output are high-Z
35	SHLR	Left or Right Display Control
36	VCC	Digital Power
37	UPDN	Up / Down Display Control
38	GND	Digital Ground
39	AGND	Analog Ground
40	AVDD	Analog Power
41	VCOM	Common Voltage
42	DITH	Dithering setting DITH="H" 6bit resolution(last 2 bit of input data truncated) (default setting) DITH="L" 8bit resolution

43,44	NC	Not connect
45	V10	Gamma correction voltage reference
46	V9	Gamma correction voltage reference
47	V8	Gamma correction voltage reference
48	V7	Gamma correction voltage reference
49	V6	Gamma correction voltage reference
50	V5	Gamma correction voltage reference
51	V4	Gamma correction voltage reference
52	V3	Gamma correction voltage reference
53	V2	Gamma correction voltage reference
54	V1	Gamma correction voltage reference
55	NC	Not connect
56	VGH	Positive Power for TFT
57	VCC	Digital Power
58	VGL	Negative Power for TFT
59	GND	Digital Ground
60	NC	Not connect

BL PIN-MAP

No.	Symbol	Description
1	LEDA	Backlight LED Anode
2	LEDK	Backlight LED Cathoder

【Note1】 Mating connector: HIROSE, FH28-60S-0.5SH, 60pin,pitch = 0.5mm

【Note2】 SHLR: left or right setting

UPDN: up or down setting

SHLR	UPDN	Data shifting
DVDD	GND	Left→Right , Up→Down(default)
GND	GND	Right→Left , Up→Down
DVDD	DVDD	Left→Right , Down→Up
GND	DVDD	Right→Left , Down→Up

Definition of scanning direction.

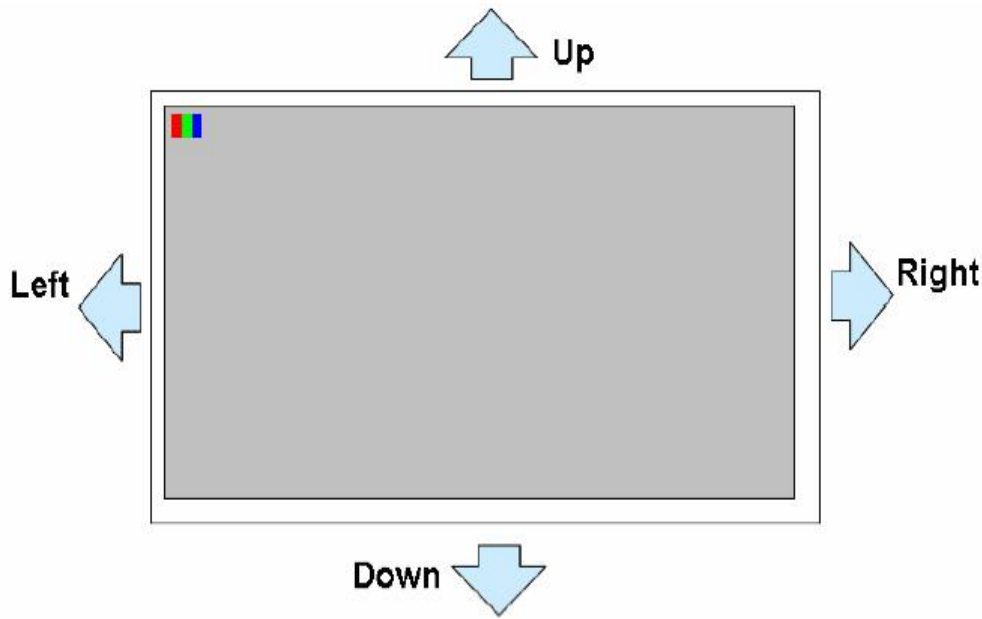

4. Absolute Maximum Rating

Item	Symbol	MIN	MAX	Unit	Remark
Supply Voltage	V_{DD}	-0.5	5.0	V	
Operating Temperature	T_{OPR}	-20	70	°C	
Storage Temperature	T_{STG}	-30	80	°C	

5. Electrical Characteristics

5.1 TFT LCD Module

Item	Symbol	Min.	Typ.	Max.	Unit	Note
Supply Voltage	Vcc	3.0	3.3	3.6	V	
	VGH	12	15	23	V	
	VGL	-12	-7	-5	V	
	AVDD	9.9	10	10.1	V	
VCOM	VCOMin	-	3.4	-	V	
Input signal voltage	ViH	0.7 Vcc	-	Vcc	V	Note (1)
	ViL	0	-	0.3 Vcc	V	
Current of power supply	IDD	-	12.37	-	mA	Vcc =3.3V
	IADD	-	13.599	-	mA	AVDD=10 V (Black)
	IGH	-	0.099	-	mA	VGH=15V
	IGL	-	0.371	-	mA	VGL= -7V
Input level of V1~V5	Vx	AVDD/2-		AVDD-0.1-	V	
Input level of V6~V10	Vx	0.1-		AVDD/2-	V	

Note (1): HSYNC, VSYNC, DE, Digital Data

Note (2): Be sure to apply the power voltage as the power sequence spec.

Note (3): DGND=AGND=0V,)

5.2 AC Characteristics

Item	Symbol	Min.	Typ.	Max.	Unit	Note
DCLK cycle time	Tcph	25			ns	
DCLK frequency	fclk		30	40	MHz	
DCLK pulse duty	Tcwh	40	50	60	%	
VSD setup time	Tvst	8			ns	
VSD hold time	Tvhd	8			ns	
HSD setup time	Thst	8			ns	
HSD hold time	Thhd	8			ns	
Data setup time	Tdsu	8			ns	
Data hold time	Tdhd	8			ns	
DE setup time	Tesu	8			ns	
DE hold time	Tehd	8			ns	
Horizontal display area	thd		800		Tcph	
HSD period time	th		928		Tcph	
HSD pulse width	thpw	1	48		Tcph	
HSD back porch	thb		88		Tcph	
HSD front porch	thfp		40		Tcph	
Vertical display area	tvd		480		th	
VSD period time	tv		525		th	
VSD pulse width	tvpw		3		th	
VSD back porch	tvb		32		th	
VSD front porch	tvfp		13		th	

5.3 LED Driving Conditions

Item	Symbol	MIN	TYP	MAX	Unit	Remark
Forward Current	I_F	-	160	-	mA	
Forward Voltage	V_F	8.6	9.6	10.6	V	
Backlight Power consumption	W_{BL}	-	1.536	-	W	
LED Lifetime		-	30000	-	Hrs	

Note 1: Each LED: $I_F = 20 \text{ mA}$, $V_F = 3.2 \pm 0.2 \text{ V}$.

Note 2: Optical performance should be evaluated at $T_a = 25^\circ \text{C}$ only.

Note 3: If LED is driven by high current, high ambient temperature & humidity condition. The life Time of LED will be reduced. Operating life means brightness goes down to 50% initial brightness. Typical operating life time is estimated data.

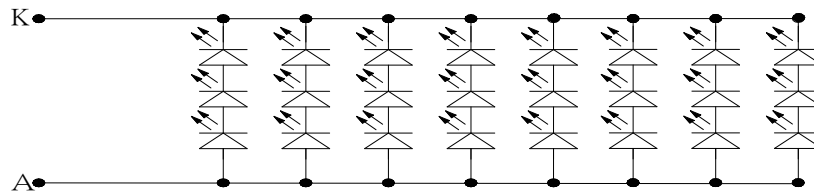

CIRCUIT DIAGRAM

Figure: LED connection of backlight(Constant Current)

5.4 Block Diagram

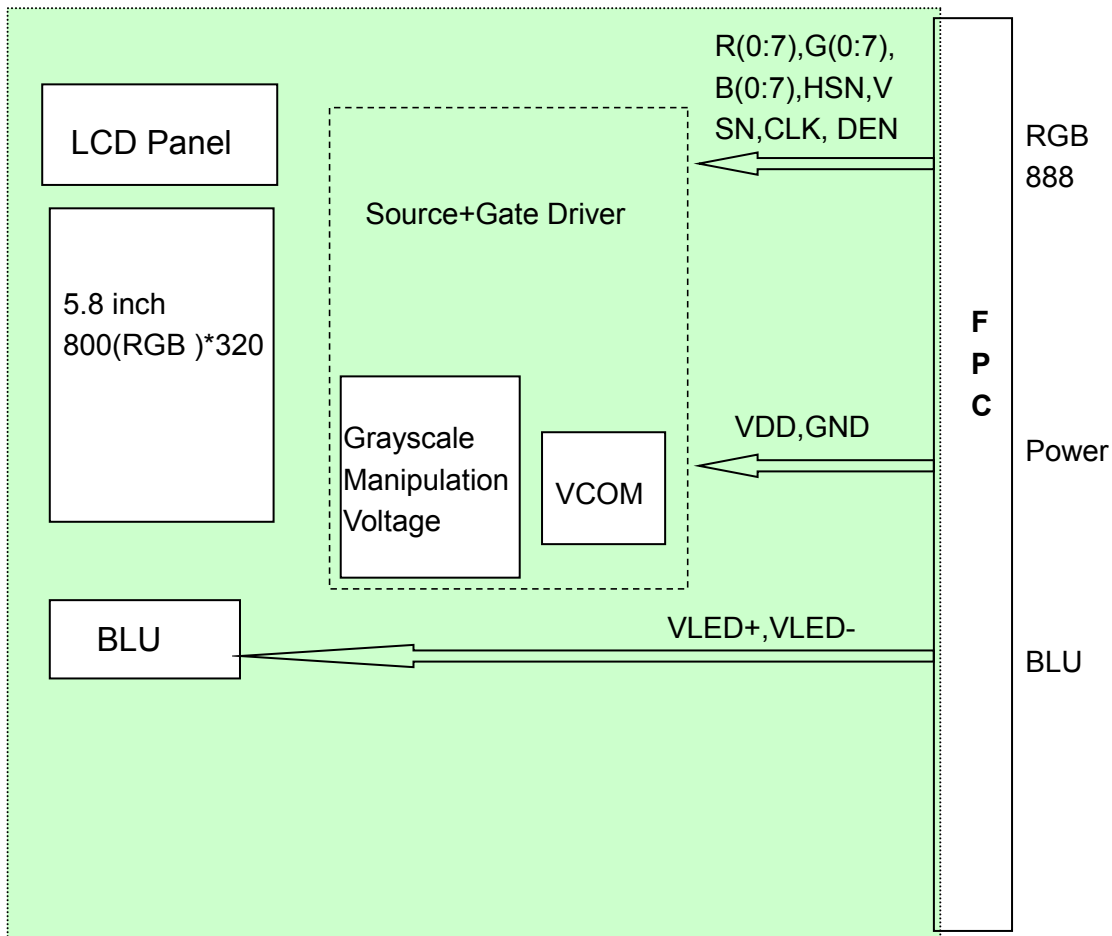

6. Interface Timing

6.1 Timing Diagram of Interface Signal

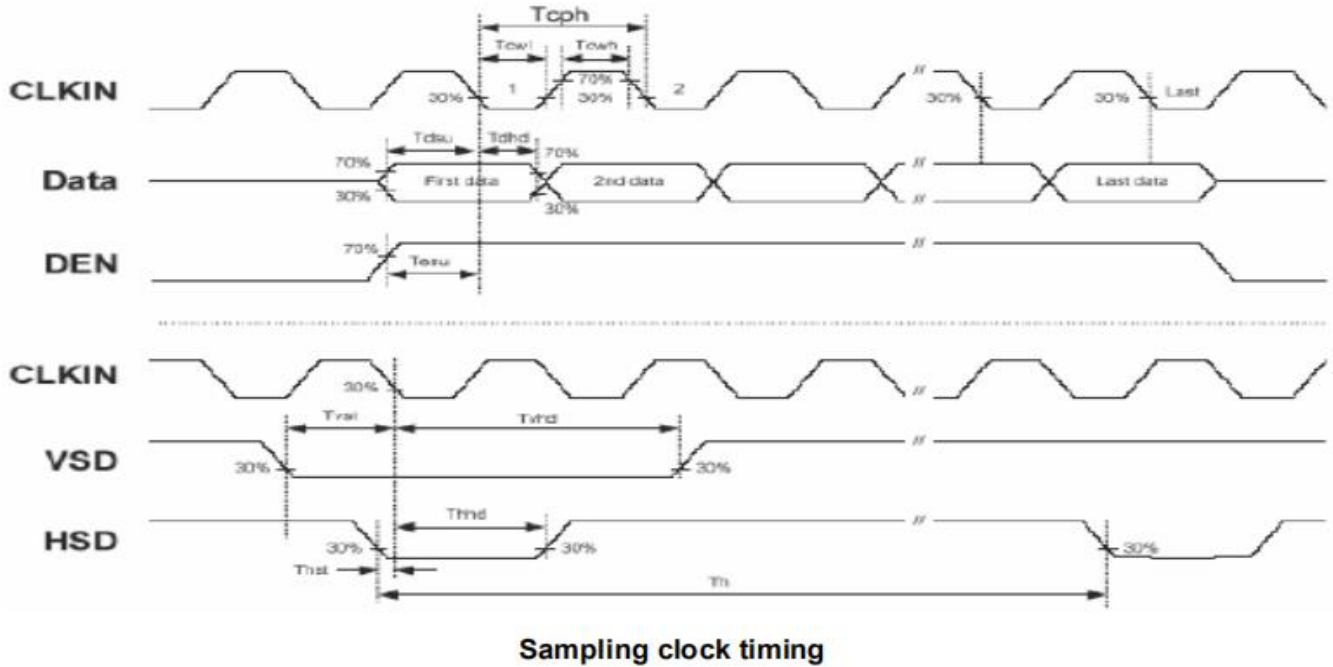

Horizontal input timing

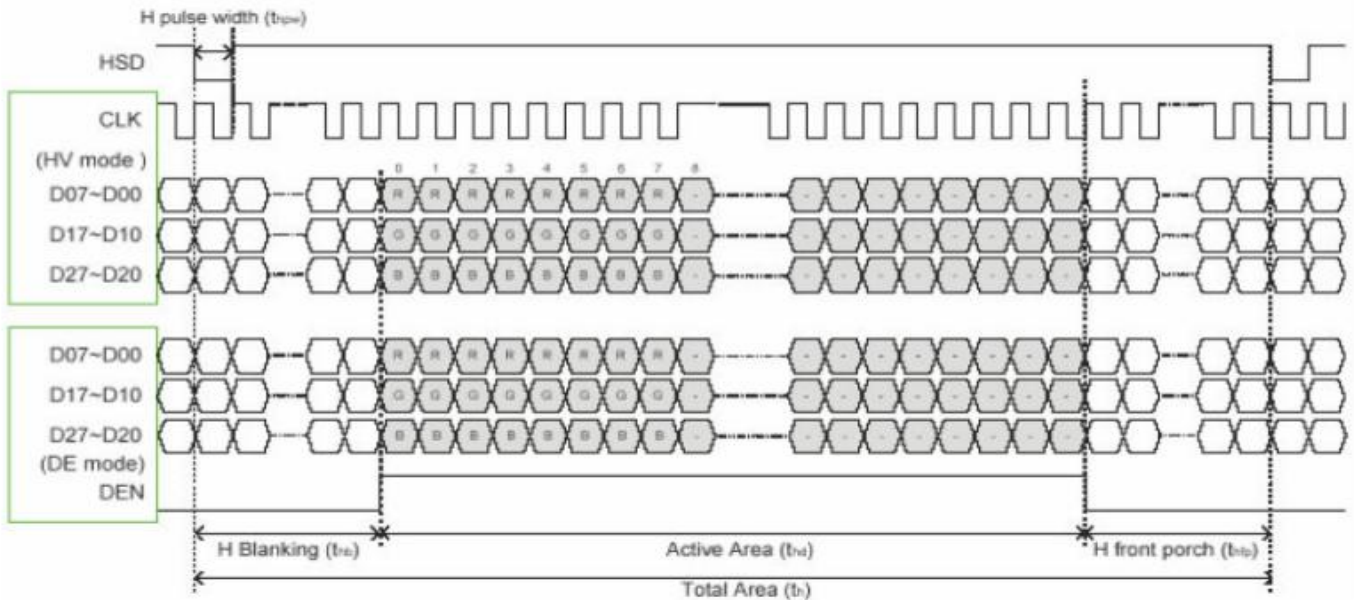

Vertical Input timing

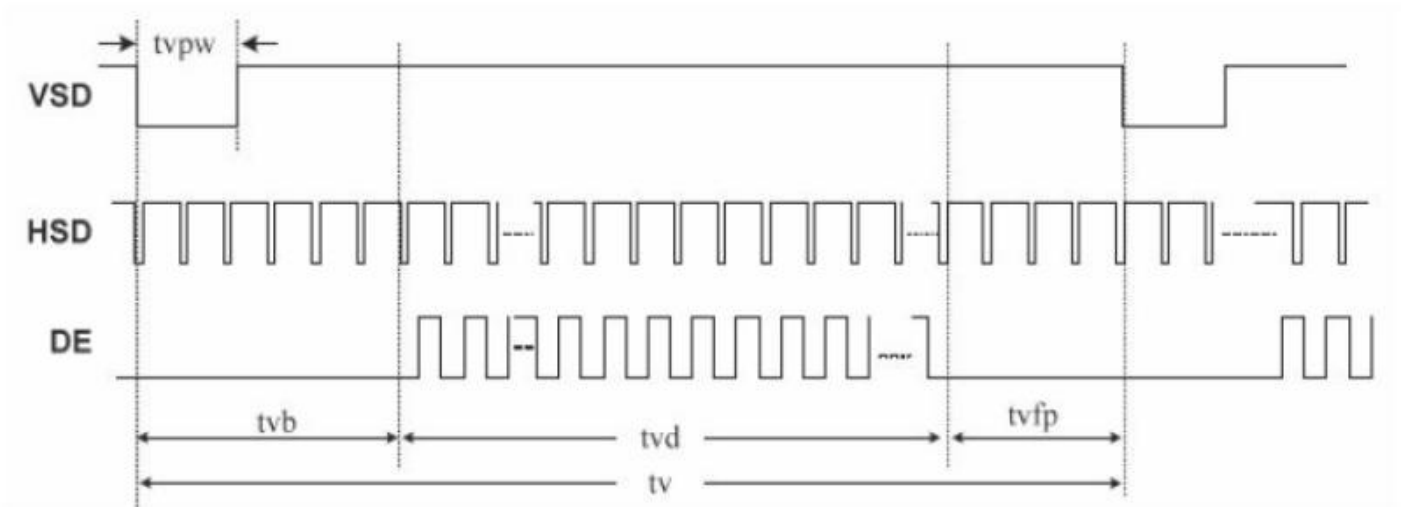

Vertical timing

6.2 Power Sequence

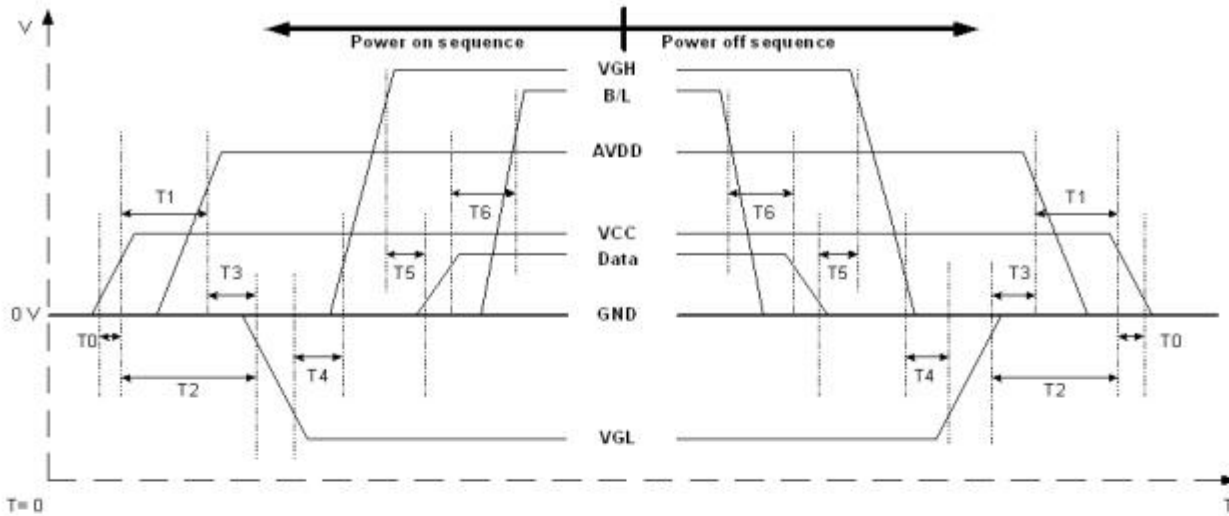

Item	Min.	Typ.	Max.	Unit
T0	0.5	--	20	msec
T1	16			msec
T2	20			msec
T3	0			msec
T4	20		--	msec
T5	20			msec
T6	50			msec

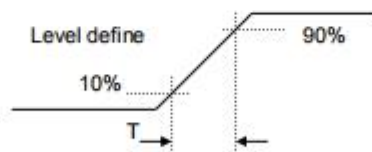

Power On Sequence: VCC-> AVDD -> VGL -> VGH -> Data -> B/L

Power Off Sequence: B/L-> Data -> VGH -> VGL -> AVDD -> VCC

Notes: Data include R0~R7, G0~G7, B0~B7, HSD, VSD, DCLK, SHLR, UPDN, DE MODE, RSTB, STBYB, SHLR, UPDN, DITH

6.3 Gamma Circuit

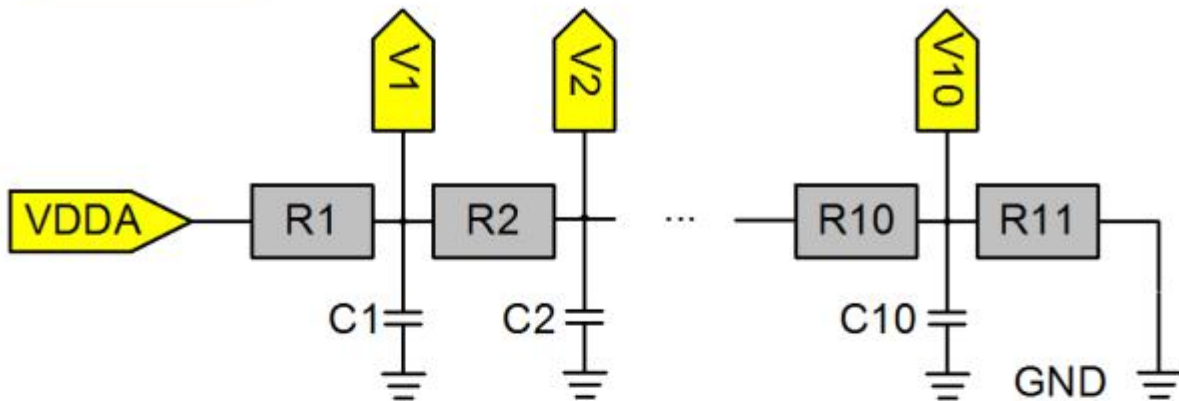

Gamma volt.(V)	Gamma Res.(Ω)	Gamma Cap.(μF)
VDDA	10.000	R1 71.5 C1 ≥ 4.7
V1	9.389	R2 221.0 C2 ≥ 4.7
V2	7.499	R3 40.2 C3 ≥ 4.7
V3	7.155	R4 34.0 C4 ≥ 4.7
V4	6.865	R5 150.0 C5 ≥ 4.7
V5	5.582	R6 54.9 C6 ≥ 4.7
V6	5.113	R7 205.0 C7 ≥ 4.7
V7	3.360	R8 48.7 C8 ≥ 4.7
V8	2.944	R9 56.2 C9 ≥ 4.7
V9	2.463	R10 237.0 C10 ≥ 4.7
V10	0.437	R11 51.1

Vertical timing :

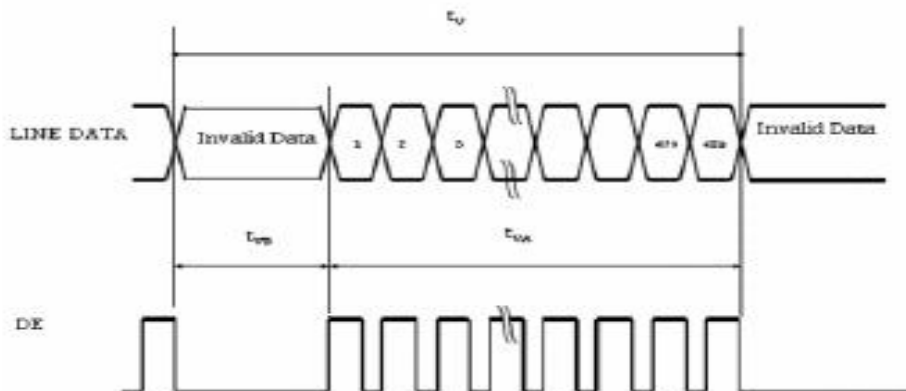

7. Optical Characteristics

Items		Symbol	Condition	Min.	Typ.	Max.	Unit	Remark	Note
Transmittance (With PZ)		T	-	3.77	4.1	-	ms	FIG.1	Note4
Contrast Ratio		CR		480	600	-	-	FIG.2	Note1
Surface luminance		LV	$\theta = 0^\circ$	450	500	-	cd/m2	FIG.2	Note2
Response Time	Rising	TR	$\theta = 0^\circ$		2	4	msec	FIG.2	Note3
	Falling	TF			6	12			
NTSC		-	$\theta = 0^\circ$	-	50	-	%	FIG.2	Note5
Viewing angle		θ_T	Center CR \geq 10	-	65	-	deg	FIG.3	Note6
		θ_B		-	55	-	deg	FIG.3	
		θ_L		-	65	-	deg	FIG.3	
		θ_R		-	65	-	deg	FIG.3	
Chromaticity	Red	R _X	$\theta = 0^\circ$ $\phi = 0^\circ$ T _a =25°	TBD	TBD	TBD	-	FIG.2 CIE1931	Note5
		R _Y		TBD	TBD	TBD	-		
	Green	G _X		TBD	TBD	TBD	-		
		G _Y		TBD	TBD	TBD	-		
	Blue	B _X		TBD	TBD	TBD	-		
		B _Y		TBD	TBD	TBD	-		
	White	W _X		TBD	TBD	TBD	-		
		W _Y		TBD	TBD	TBD	-		

Note1. Definition of contrast ratio

Contrast ratio(Cr) is defined mathematically by the following formula. For more information see FIG.2.

$$\text{Contrast ratio} = \frac{\text{Luminance measured when LCD on the "White" state}}{\text{Luminance measured when LCD on the "Black" state}}$$

For contrast ratio, Surface Luminance, Luminance uniformity and CIE, the testing data is based on TOPCON's BM-5 or BM-7 photo detector or compatible.

Note2. Definition of surface luminance.

Surface luminance is the luminance with all pixels displaying white. For more information see FIG.2.

L_v = Average Surface Luminance with all white pixels ($P_1, P_2, P_3, \dots, P_n$)

Note3. Definition of luminance uniformity

The luminance uniformity in surface luminance is determined by measuring luminance at each test position 1 through n, and then dividing the maximum luminance of n points luminance by minimum luminance of n points luminance. For more information see FIG.2.

$$YU = \frac{\text{Minimum surface luminance with all white pixels } (P_1, P_2, P_3, \dots, P_n)}{\text{Maximum surface luminance with all white pixels } (P_1, P_2, P_3, \dots, P_n)}$$

Note4. Definition of response time

The response time is defined as the LCD optical switching time interval between "White" state and "Black" state. Rise time (T_r) is the time between photo detector output intensity changed from 90% to 10%. And fall time (T_f) is the time between photo detector output intensity changed from 10% to 90%.

For additional information see FIG1.

Note5. Definition of color chromaticity (CIE1931)

CIE (x,y) chromaticity, The x,y value is determined by screen active area center position P5. For more information see FIG.2.

Note6. Definition of viewing angle

Viewing angle is the angle at which the contrast ratio is greater than 10. Angles are determined for the horizontal or x axis and the vertical or y axis with respect to the z axis which is normal to the LCD surface. For more information see FIG.3.

For viewing angle and response time testing, the testing data is based on Autronic-Melchers' s ConoScope or DMS series Instruments or compatible.

FIG.1.The definition of response Time

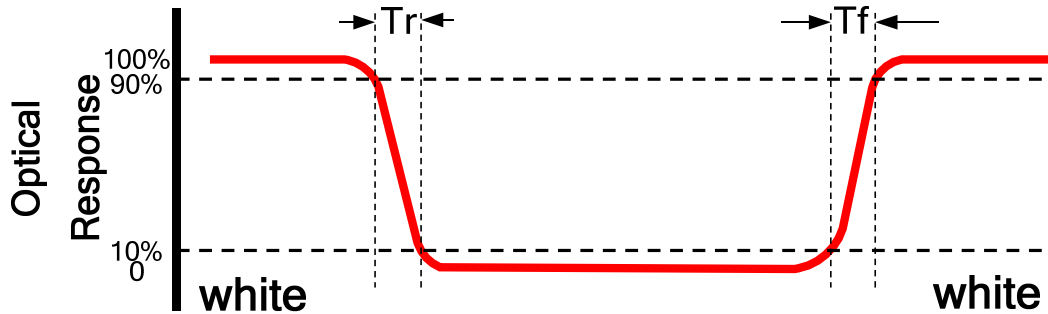

FIG.2. Measuring method for contrast ratio, surface luminance,

luminance uniformity, CIE (x,y) chromaticity

Size : $S \leq 5''$ (see Figure a) A : 5 mm B : 5 mm

H,V : Active area

Light spot size $\varnothing = 5\text{mm}$ (BM-5) or $\varnothing = 7.7\text{mm}$ (BM-7) 50cm distance or compatible distance from the LCD surface to detector lens.

test spot position : see Figure a.

measurement instrument : TOPCON's luminance meter BM-5 or BM-7 or compatible (see Figure c).

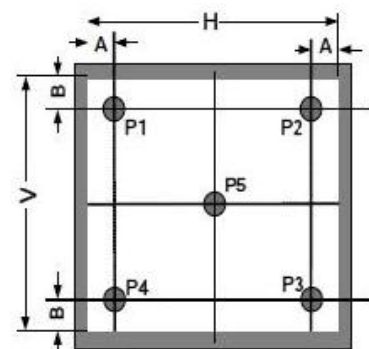

Figure a

Size : $5'' < S \leq 12.3''$ (see Figure b) H,V : Active area

Light spot size $\varnothing = 5\text{mm}$ (BM-5) or $\varnothing = 7.7\text{mm}$ (BM-7) 50cm distance or compatible distance from the LCD surface to detector lens.

test spot position : see Figure b.

measurement instrument : TOPCON's luminance meter BM-5 or BM-7 or compatible (see Figure c).

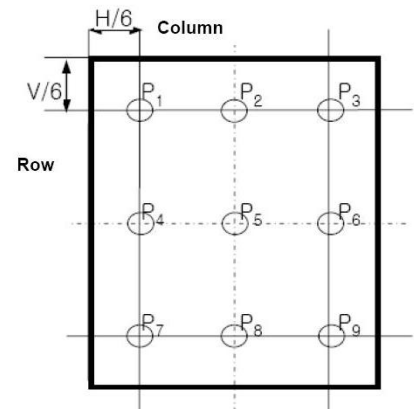

Figure b

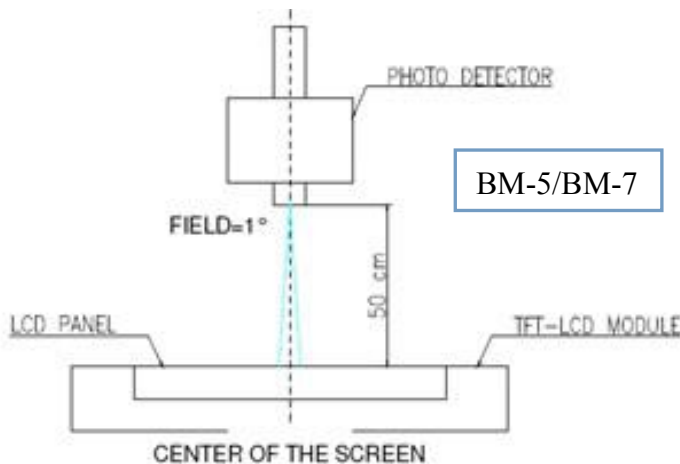
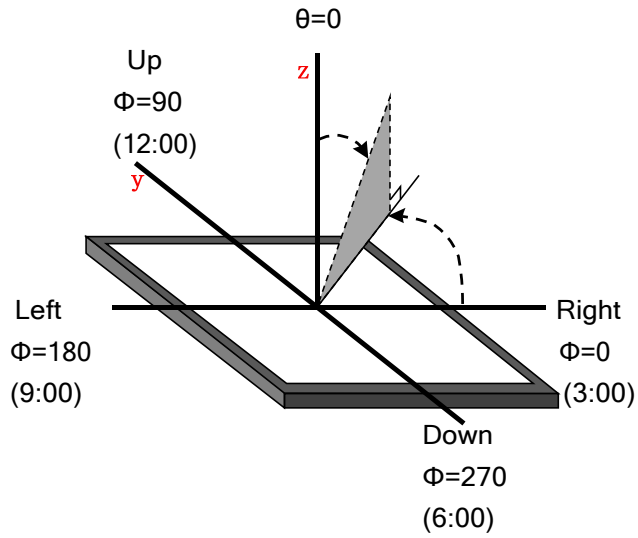

Figure c

FIG.3.The definition of viewing angle



8. Environmental / Reliability Tests

No	Test Item	Condition	Remarks
1	High Temperature Operation	Ts= +70°C, 96hrs	Note 1 IEC60068-2-2, GB2423. 2-89
2	Low Temperature Operation	Ta= -20°C, 96hrs	Note 2 IEC60068-2-1 GB2423.1-89
3	High Temperature Storage	Ta= +80°C, 120hrs	IEC60068-2-2 GB2423. 2-89
4	Low Temperature Storage	Ta= -30°C, 120hrs	IEC60068-2-1 GB/T2423.1-89
5	High Temperature & Humidity Storage	Ta= +60°C, 90% RH max, 120 hours	IEC60068-2-3 GB/T2423.3-2006
6	Thermal Shock (Non-operation)	-20°C 30 min ~ +60°C 30 min Change time: 5min, 30 Cycle	Start with cold temperature, end with high temperature IEC60068-2-14, GB2423.22-87
7	Electro Discharge (Operation)	Static C=150pF, R=330 Ω, 5 points/panel Air:±8KV, 5 times; Contact: ±4KV, 5 times; (Environment: 15°C ~ 35°C, 30% ~ 60%, 86Kpa ~ 106Kpa)	IEC61000-4-2 GB/T17626.2-1998
8	Vibration (Non-operation)	Frequency range: 10~55Hz, Stroke: 1mm Sweep: 10Hz~55Hz~10Hz 2 hours for each direction of X .Y. Z. (package condition)	IEC60068-2-6 GB/T2423.5-1995
9	Shock (Non-operation)	60G 6ms, ± X, ±Y , ± Z 3 times for each direction	IEC60068-2-27 GB/T2423.5-1995
10	Package Drop Test	Height: 80 cm, 1 corner, 3 edges, 6 surfaces	IEC60068-2-32 GB/T2423.8-1995

- Note: 1. Ts is the temperature of panel's surface.
2. Ta is the ambient temperature of sample.
3. The size of sample is 5pcs.

9. Mechanical Drawing

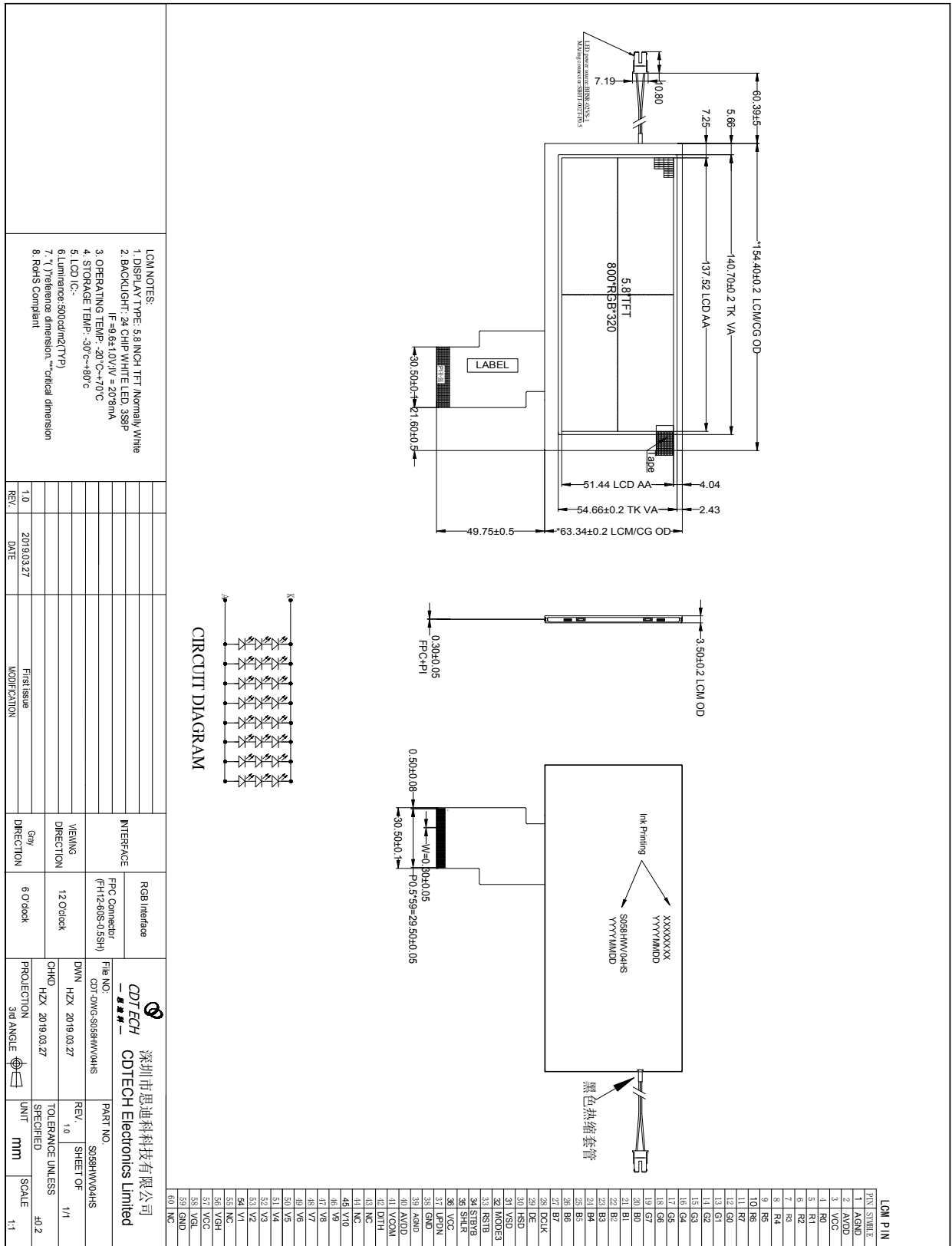



10. Packing

TBD

11. TFT-LCD Module Inspection Criteria

11.1 Scope

The incoming inspection standards shall be applied to TFT - LCD Modules (hereinafter Called "Modules") that supplied by CDTech Technology LTD.

11.2 Incoming Inspection

The customer shall inspect the modules within twenty calendar days of the delivery date (the “inspection period”) at its own cost. The result of the inspection (acceptance or rejection) shall be recorded in writing, and a copy of this writing will be promptly sent to The seller, If the results of the inspecting from buyer does not send to the seller within twenty Calendar days of the delivery date. The modules shall be regards as acceptance. Should the customer fail to notify the seller within the inspection period, the buyers Right to reject the modules shall be lapsed and the modules shall be deemed to have Been accepted by the buyer

11.3 Inspection Sampling

- 3.1. Lot size: Quantity per shipment lot per model
- 3.2. Sampling type: Normal inspection, Single sampling
- 3.3. Inspection level: II
- 3.4. Sampling table: MIL-STD-105E
- 3.5. Acceptable quality level (AQL)
Major defect: AQL=0.65 Minor defect: AQL=1.50

11.4 Inspection Conditions

4.1 Ambient conditions:

- a. Temperature: Room temperature $25 \pm 5^{\circ}\text{C}$
- b. Humidity: $(60 \pm 10) \% \text{RH}$
- c. Illumination: Single fluorescent lamp non-directive (300 to 700 Lux)

4.2 Viewing distance

The distance between the LCD and the inspector's eyes shall be at least 35 ± 5 cm.

4.3 Viewing Angle

U/D: $45^{\circ} / 45^{\circ}$, L/R: $45^{\circ} / 45^{\circ}$

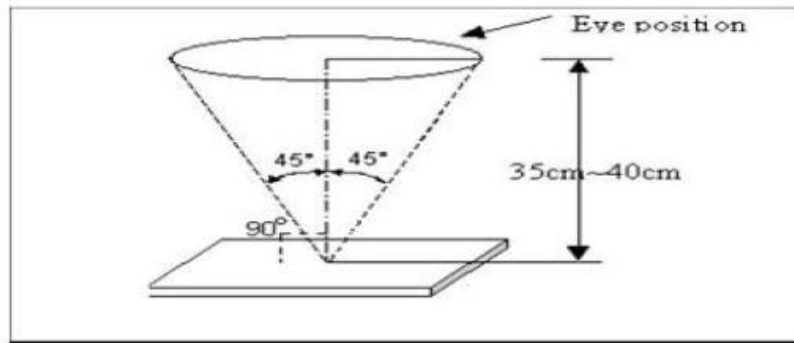

11.5 Inspection Criteria

Defects are classified as major defects and minor defects according to the degree of Defectiveness defined herein.

11.5.1 Major defect

Item No	Items to be inspected	Inspection Standard
5.1.1	All functional defects	1) No display 2) Display abnormally 3) Short circuit 4) line defect
5.1.2	Missing	Missing function component
5.1.3	Crack	Glass Crack

11.5.2 Minor defect

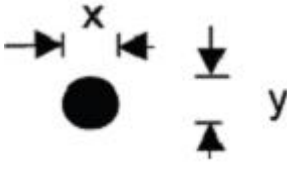
Item No	Items to be inspected	Inspection standard	
5.2.1	Spot Defect Including Black spot White spot Pinhole Foreign particle Polarizer dirt	For dark/white spot is defined $\varphi = (x+y) / 2$ 	
		Size φ (mm)	Acceptable Quantity
		$\varphi \leq 0.1$	Ignore
		$0.1 < \varphi \leq 0.2$	N \leq 3
		$0.2 < \varphi \leq 0.3$	N \leq 2
$0.3 < \varphi$	Not allowed		

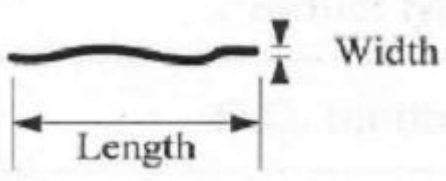
5.2.2	Line Defect Including Black line White line Scratch	Define:	
			
		Width(mm) Length(mm)	Acceptable Quantity
		$W \leq 0.03$	Ignore
		$0.03 < W \leq 0.05, L \leq 3.0$	$N \leq 2$
		$0.05 < W \leq 0.08, L \leq 3.0$	$N \leq 1$
	$0.08 < W$	Not allowed	

5.2.3	Polarizer Dent/Bubble	Size φ (mm)	Acceptable Quantity
		$\varphi \leq 0.1$	Ignore
		$0.1 < \varphi \leq 0.2$	$N \leq 3$
		$0.2 < \varphi \leq 0.3$	$N \leq 2$
		$0.3 < \varphi$	Not allowed

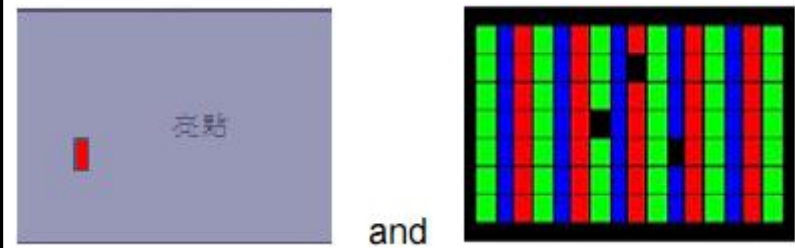
5.2.4	Electrical Dot Defect	Bright and Black dot define:			
					
		Two Adjacent Dot			
		Inspection pattern: Full white 、 Full black 、 Red 、 green and blue screens			
		Item	Acceptable Quantity		
			I	O	Total
Black dot defect	2	4	5		
Bright dot defect	1	3	3		
Total Dot	2	5	6		
3% Bright Dot is allowed					

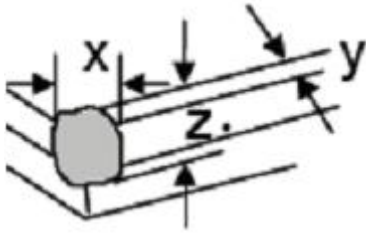
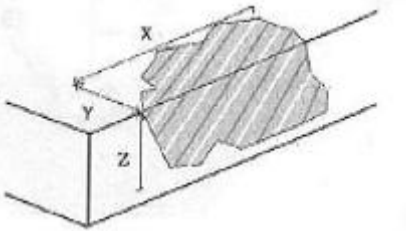
5.2.5	Glass defect		
		1. Corner Fragment:	
		Size(mm)	Acceptable Quantity
		$X \leq 3\text{mm}$ $Y \leq 1\text{mm}$ $Z \leq T$	Ignore T: Glass thickness X: Length Y: Width Z: thickness
		2. Side Fragment: 	
		Size(mm)	Acceptable Quantity
$X \leq 5.0\text{mm}$ $Y \leq 1\text{mm}$ $Z \leq T$	T: Glass thickness X: Length Y: Width Z: thickness		

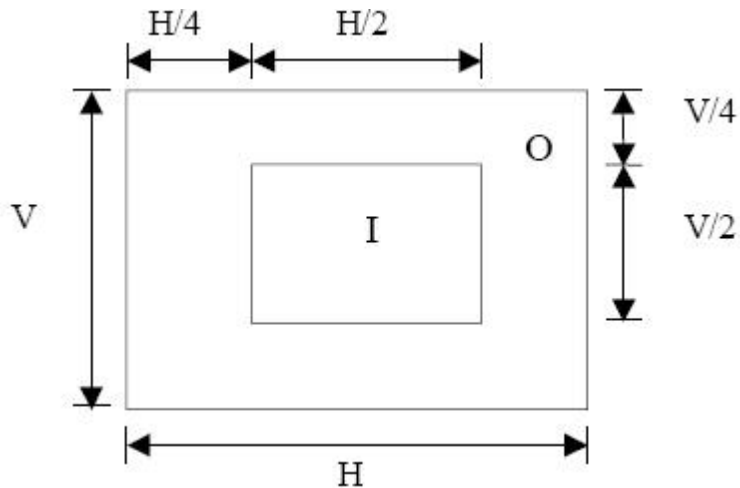

I area & O area

- Note:
- 1). Dot defect is defined as the defective area of the dot area is larger than 50% of the dot area.
 - 2). The distance between two bright dot defects (red, green, blue, and white) should be larger than 15mm.
 - 3). The distance between black dot defects or black and bright dot defects should be more than 5mm apart.
 - 4). Polarizer bubble is defined as the bubble appears on active display area. The defect of polarizer bubble shall be ignored if the polarizer bubble appears on the outside of active display area.

11.6 Mechanics specification

As for the outside dimension, weight of the modules, please refer to product specification
For more details

12. Precautions for Use of LCD modules

12.1 Handling Precautions

12.1.1. The display panel is made of glass. Do not subject it to a mechanical shock by dropping it from a high place, etc.

12.1.2. If the display panel is damaged and the liquid crystal substance inside it leaks out, be sure not to get any in your mouth, if the substance comes into contact with your skin or clothes, promptly wash it off using soap and water.

12.1.3. Do not apply excessive force to the display surface or the adjoining areas since this may cause the color tone to vary.

12.1.4. The polarizer covering the display surface of the LCD module is soft and easily scratched. Handle this polarizer carefully.

12.1.5. If the display surface is contaminated, breathe on the surface and gently wipe it with a soft dry cloth. If still not completely clear, moisten cloth with one of the following solvents:

- Isopropyl alcohol
- Ethyl alcohol

Solvents other than those mentioned above may damage the polarizer. Especially, do not use the following:

- Water
- Ketene
- Aromatic solvents

12.1.6. Do not attempt to disassemble the LCD Module.

12.1.7. If the logic circuit power is off, do not apply the input signals.

12.1.8. To prevent destruction of the elements by static electricity, be careful to maintain an optimum work environment.

12.1.8.1. Be sure to ground the body when handling the LCD Modules.

12.1.8.2. Tools required for assembly, such as soldering irons, must be properly ground.

12.1.8.3. To reduce the amount of static electricity generated, do not conduct assembly and other work under dry conditions.

12.1.8.4. The LCD Module is coated with a film to protect the display surface. Be care when peeling off this protective film since static electricity may be generated.

12.2 Storage Precautions

12.2.1. When storing the LCD modules, avoid exposure to direct sunlight or to the light of fluorescent lamps.

12.2.2. The LCD modules should be stored under the storage temperature range. If the LCD modules will be stored for a long time, the recommend condition is:

Temperature : 0°C ~ 40°C Relatively humidity: ≤80%

12.2.3. The LCD modules should be stored in the room without acid, alkali and harmful gas.

12.3 Transportation Precautions

The LCD modules should be no falling and violent shocking during transportation, and also should avoid excessive press, water, damp and sunshine.