

--	--	--	--	--

SPEC. NUMBER	PRODUCT GROUP TFT- LCD	REV. P0	ISSUE DATE 2020.07.03	PAGE 1 OF 31
--------------	---------------------------	------------	--------------------------	-----------------

**B5 AV156FHB-N10**  
**Product Specification Rev.P0**

SUPPLIER	



SPEC. NUMBER

PRODUCT GROUP

REV.

ISSUE DATE

PAGE

TFT- LCD

P0

2020.07.03

3 OF 31

## Contents

No.	Items	Page
	REVISION HISTORY	2
	CONTENTS	3
1.0	General Description	4
2.0	Absolute Maximum ratings	6
3.0	Electrical specifications.	7
4.0	Optical Specification	9
5.0	Interface Connection	13
6.0	Signal Timing Specification	16
7.0	Input Signals, Display Colors & Gray Scale of Colors	18
8.0	Power Sequence	19
9.0	Connector description	20
10.0	Mechanical Characteristics	21
11.0	Reliability Test	22
12.0	Handling & Cautions.	22
13.0	Label	23
14.0	Packing information	25
15.0	Mechanical Outline Dimension	26
16.0	EDID Table	28

## 1.0 GENERAL DESCRIPTION

### 1.1 Introduction

AV156FHB-N10 is a color active matrix TFT LCD module using amorphous silicon TFT's (Thin Film Transistors) as an active switching devices. This module has a 15.6 inch diagonally measured active area with FHD resolutions (1920 horizontal by 1080 vertical pixel array). Each pixel is divided into RED, GREEN, BLUE dots which are arranged in vertical Stripe and this module can display 262,144 colors. The TFT-LCD panel used for this module is a low reflection and higher color type. Therefore, this module is suitable for Notebook PC. The LED Driver for back-light driving is built in this model.

All input signals are eDP1.2 interface compatible.

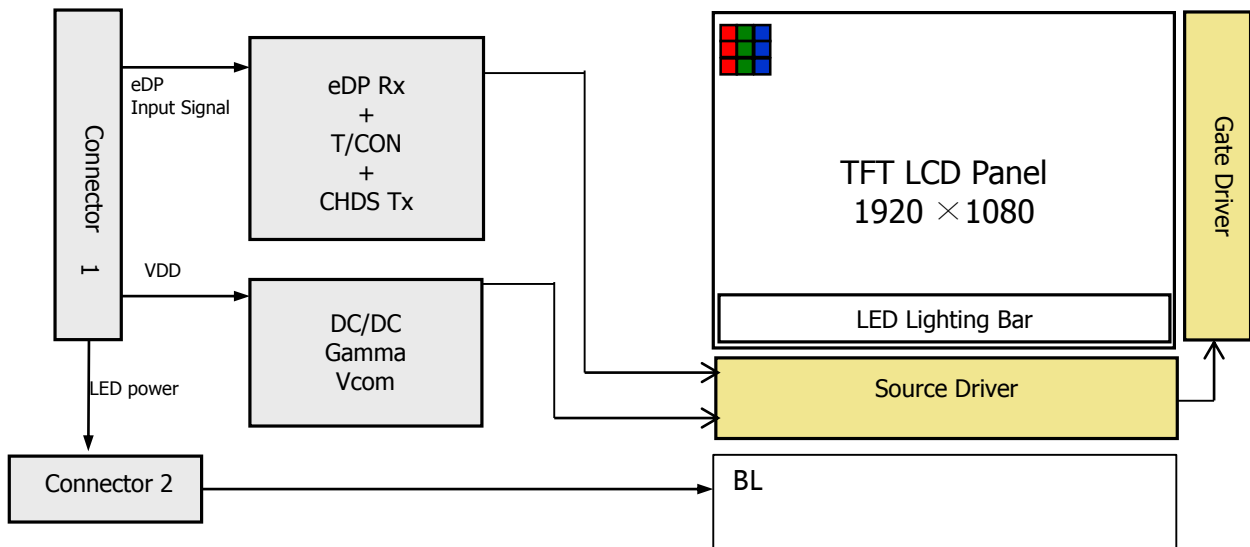

### 1.2 Features

- 2 lane eDP Interface with 2.7Gbps Link Rates
- Thin and light weight
- 6-bit color depth, display 262K colors
- Green Product (RoHS & Halogen free product)
- Low driving voltage and low power consumption
- On board EDID chip

SPEC. NUMBER

PRODUCT GROUP

REV.

ISSUE DATE

PAGE

TFT- LCD

P0

2020.07.03

5 OF 31

&lt;Table 1. General Specifications&gt;

Parameter	Specification	Unit	Remarks
Active area	344.16 (H) × 193.59 (V)	mm	
Number of pixels	1920 (H) × 1080 (V)	pixels	
Pixel pitch	0.17925 (H) X 0.17925 (V)	mm	
Pixel arrangement	RGB Vertical stripe		
Display colors	262K	colors	
Display mode	Normally Black		
Dimensional outline	359.5(H)*223.8(V) (W/PCB)*3.2(Max)	mm	
Weight	TBD	g	
Surface treatment	AG		
Back-light	Lower Down side, 1-LED Lighting Bar type		Note 1

## 2.0 ABSOLUTE MAXIMUM RATINGS

The followings are maximum values which, if exceed, may cause faulty operation or damage to the unit. The operational and non-operational maximum voltage and current values are listed in Table 2.

< Table 2. Absolute Maximum Ratings >

Ta=25+/-2°C

Parameter	Symbol	Min.	Max.	Unit	Remarks
Power Supply Voltage	V <sub>DD</sub>	-0.3	4.0	V	Note 1
Logic Supply Voltage	V <sub>IN</sub>	V <sub>SS</sub> -0.3	V <sub>DD</sub> +0.3	V	
Operating Temperature	T <sub>OP</sub>	0	+50	°C	Note 2
Storage Temperature	T <sub>ST</sub>	-20	+60	°C	

- Notes : 1. Permanent damage to the device may occur if maximum values are exceeded functional operation should be restricted to the condition described under normal operating conditions.
2. Temperature and relative humidity range are shown in the figure below.  
 95 % RH Max. ( 40 °C ≥ Ta)  
 Maximum wet - bulb temperature at 39 °C or less. (Ta > 40 °C) No condensation.

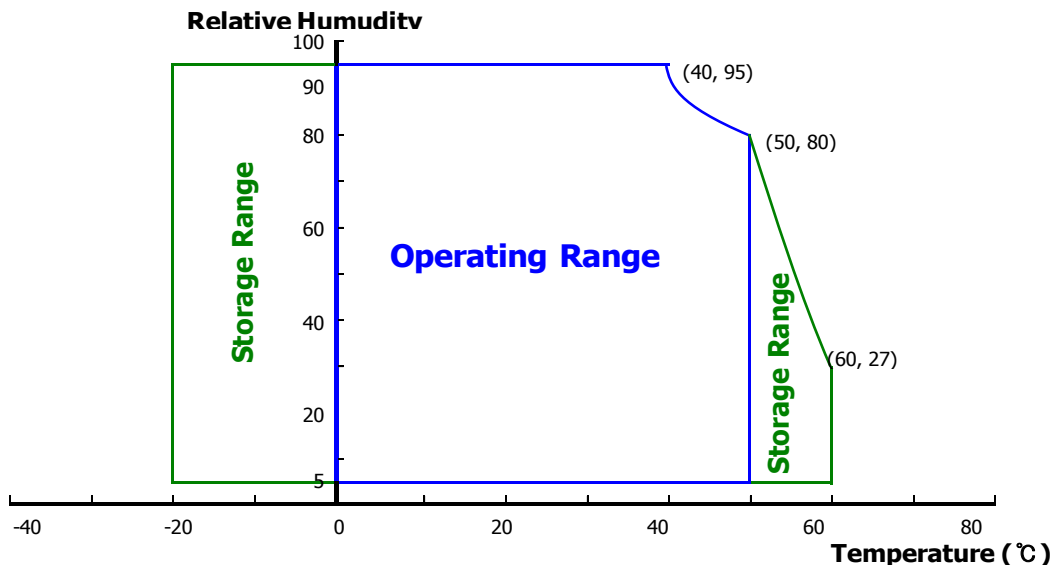

**3.0 ELECTRICAL SPECIFICATIONS****3.1 Electrical Specifications**

&lt; Table 3. Electrical specifications &gt;

Ta=25+/-2°C

Parameter		Min.	Typ.	Max.	Unit	Remarks
Power Supply Voltage	$V_{DD}$	3.0	3.3	3.6	V	Note 1
Permissible Input Ripple Voltage	$V_{RF}$	-	-	100	mV	At $V_{DD} = 3.3V$
Power Supply Current	$I_{DD}$	-	303	-	mA	Note 1
Differential Input Voltage	$V_{ID}$	200	-	600	mV	
Power Consumption	$P_D$	-	1.0	1.8	W	Note 1

Notes : The supply voltage is measured and specified at the interface connector of LCM.  
The current draw and power consumption specified is for 3.3V at 25°C.

a) Typ : Mosaic Pattern

b) Max : R/G/B Pattern

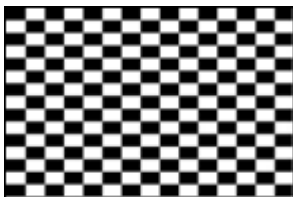

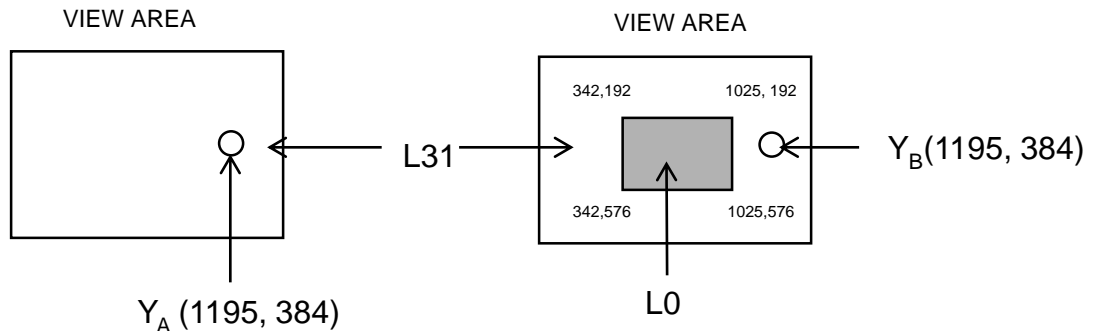
**Figure 5. Cross Modulation Test Description**

$$\text{Cross-Talk (\%)} = \left| \frac{Y_B - Y_A}{Y_A} \right| \times 100$$

Where:

$Y_A$  = Initial luminance of measured area ( $\text{cd/m}^2$ )

$Y_B$  = Subsequent luminance of measured area ( $\text{cd/m}^2$ )

The location measured will be exactly the same in both patterns

Cross-Talk of one area of the LCD surface by another shall be measured by comparing the luminance ( $Y_A$ ) of a 25mm diameter area, with all display pixels set to a gray level, to the luminance ( $Y_B$ ) of that same area when any adjacent area is driven dark (Refer to FIGURE 5).

SPEC. NUMBER		PRODUCT GROUP	REV.	ISSUE DATE	PAGE
		TFT- LCD	P0	2020.07.03	9 OF 31

**4.0 OPTICAL SPECIFICATION**

**4.1 Overview**

The test of Optical specifications shall be measured in a dark room (ambient luminance  $\leq 1$  lux and temperature =  $25 \pm 2^\circ\text{C}$ ) with the equipment of Luminance meter system (Goniometer system and PR730) and test unit shall be located at an approximate distance 50cm from the LCD surface at a viewing angle of  $\theta$  and  $\phi$  equal to  $0^\circ$ . We refer to  $\theta=0$  ( $=\theta_3$ ) as the 3 o'clock direction (the "right"),  $\theta=90$  ( $=\theta_{12}$ ) as the 12 o'clock direction ("upward"),  $\theta=180$  ( $=\theta_9$ ) as the 9 o'clock direction ("left") and  $\theta=270$  ( $=\theta_6$ ) as the 6 o'clock direction ("bottom"). While scanning  $\theta$  and/or  $\phi$ , the center of the measuring spot on the Display surface shall stay fixed. The backlight should be operating for 30 minutes prior to measurement. VDD shall be  $3.3 \pm 0.3\text{V}$  at  $25^\circ\text{C}$ . Optimum viewing angle direction is 6 o'clock.

**4.2 Optical Specifications**

<Table 5. Optical Specifications>

Parameter		Symbol	Condition	Min.	Typ.	Max.	Unit	Remark
Viewing Angle range	Horizontal	$\theta_3$	CR > 10	-	85	-	Deg.	Note 1
		$\theta_9$		-	85	-	Deg.	
	Vertical	$\theta_{12}$		-	85	-	Deg.	
		$\theta_6$		-	85	-	Deg.	
Luminance Contrast ratio		CR	$\theta = 0^\circ$	-	800			Note 2
Reproduction of color	Red	$x_R$	$\theta = 0^\circ$	-0.03	0.661	+0.03		@C light CF only
		$y_R$			0.324			
	Green	$x_G$			0.261			
		$y_G$			0.592			
	Blue	$x_B$			0.137			
		$y_B$			0.082			
Response Time (Rising + Falling)		$T_{RT}$	$T_a = 25^\circ\text{C}$ $\theta = 0^\circ$	-	30	35	ms	Note 3
Cross Talk		CT	$\theta = 0^\circ$	-	-	2.0	%	Note 4

SPEC. NUMBER	PRODUCT GROUP TFT- LCD	REV. P0	ISSUE DATE 2020.07.03	PAGE 10 OF 31

Notes :

1. Viewing angle is the angle at which the contrast ratio is greater than 10. The viewing angles are determined for the horizontal or 3, 9 o'clock direction and the vertical or 6, 12 o'clock direction with respect to the optical axis which is normal to the LCD surface (see FIGURE 1).

2. Contrast measurements shall be made at viewing angle of  $\Theta = 0$  and at the center of the LCD surface. Luminance shall be measured with all pixels in the view field set first to white, then to the dark (black) state .  
(see FIGURE 1) Luminance Contrast Ratio (CR) is defined mathematically.

$$CR = \frac{\text{Luminance when displaying a white raster}}{\text{Luminance when displaying a black raster}}$$

3. The electro-optical response time measurements shall be made as FIGURE 4 by switching the "data" input signal ON and OFF. The times needed for the luminance to change from 10% to 90% is Tr, and 90% to 10% is Td.

4. Cross-Talk of one area of the LCD surface by another shall be measured by comparing the luminance (YA) of a 25mm diameter area, with all display pixels set to a gray level, to the luminance (YB) of that same area when any adjacent area is driven dark.  
(See FIGURE 5).

### 4.3 Optical measurements

**Figure 1. Measurement Set Up**

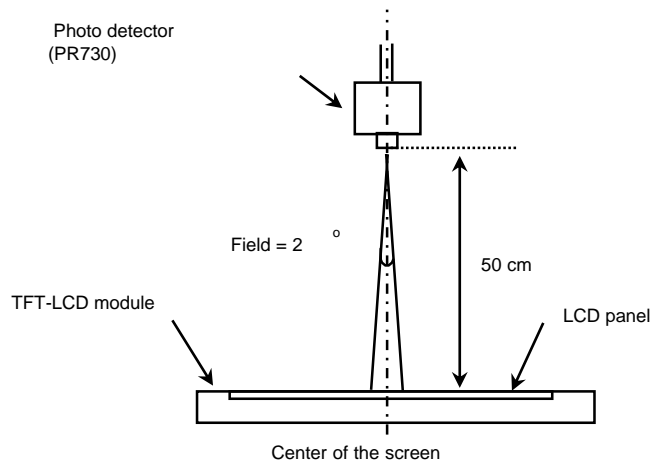

Optical characteristics measurement setup

**Figure 2. Response Time Testing**

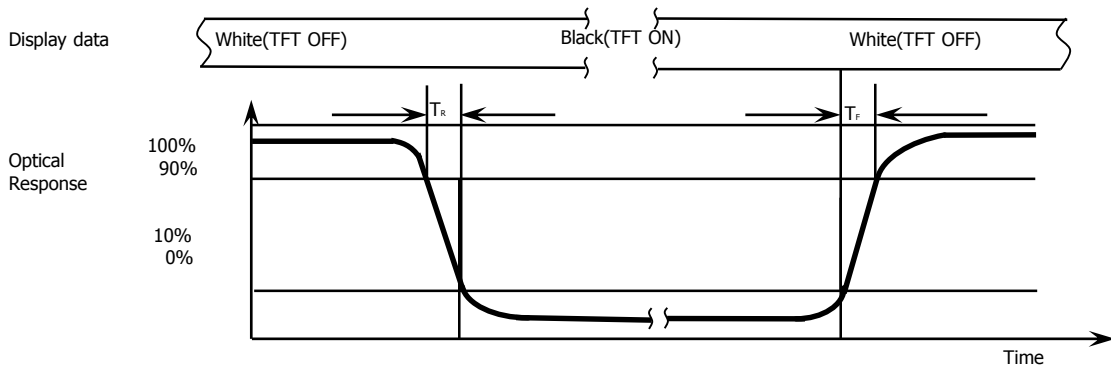

The electro-optical response time measurements shall be made as shown in FIGURE 4 by switching the “data” input signal ON and OFF. The times needed for the luminance to change from 10% to 90% is  $T_d$  and 90% to 10% is  $T_r$ .

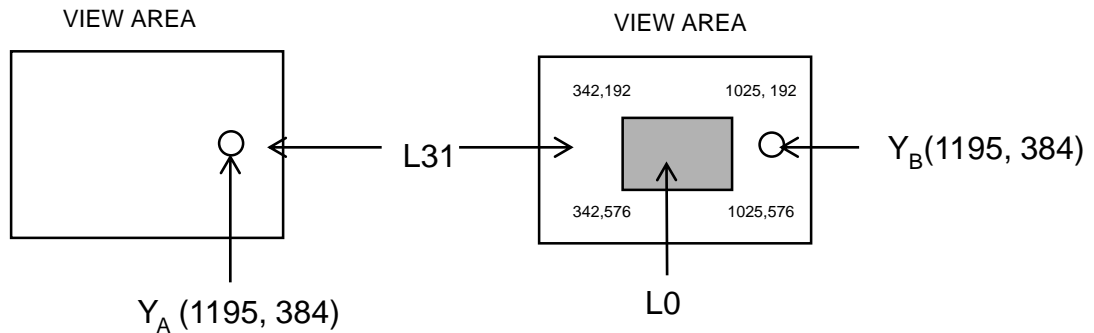
**Figure 3. Cross Modulation Test Description**

$$\text{Cross-Talk (\%)} = \left| \frac{Y_B - Y_A}{Y_A} \right| \times 100$$

Where:

$Y_A$  = Initial luminance of measured area ( $\text{cd/m}^2$ )

$Y_B$  = Subsequent luminance of measured area ( $\text{cd/m}^2$ )

The location measured will be exactly the same in both patterns

Cross-Talk of one area of the LCD surface by another shall be measured by comparing the luminance ( $Y_A$ ) of a 25mm diameter area, with all display pixels set to a gray level, to the luminance ( $Y_B$ ) of that same area when any adjacent area is driven dark (Refer to FIGURE 5).

**5.0 INTERFACE CONNECTION.****5.1 Electrical Interface Connection**

The electronics interface connector is UJU IS050-L30B-C10 or Compatible.

The connector interface pin assignments are listed in Table 6.

<Table 6. Pin Assignments for the Interface Connector>

Terminal	Symbol	Functions
Pin No.	Symbol	Description
1	CABC_ENABLE	Test enable
2	H_GND	Ground
3	LANE1_N	eDP RX channel 1 negative
4	LANE1_P	eDP RX channel 1 positive
5	H_GND	Ground
6	LANE0_N	eDP RX channel 0 negative
7	LANE0_P	eDP RX channel 0 positive
8	H_GND	Ground
9	AUX_CH_P	eDP AUX CH positive
10	AUX_CH_N	eDP AUX CH negative
11	H_GND	Ground
12	LCD_VCC	Power Supply, 3.3V (typ.)
13	LCD_VCC	Power Supply, 3.3V (typ.)
14	LCD_Self_Test	Panel self test enable
15	H_GND	Ground
16	H_GND	Ground
17	HPD	Hot plug detect output
18	NC	No Connection
19	LED1	LED cathode connection
20	LED2	LED cathode connection
21	LED3	LED cathode connection
22	LED4	LED cathode connection
23	NC	No Connection
24	Hsync	预留Hsync, 暂不开启
25	NC	No Connection
26	Vout	LED anode connection
27	Vout	LED anode connection
28	Vout	LED anode connection
29	Vout	LED anode connection
30	NC	No Connection

## 5-2. eDP Interface

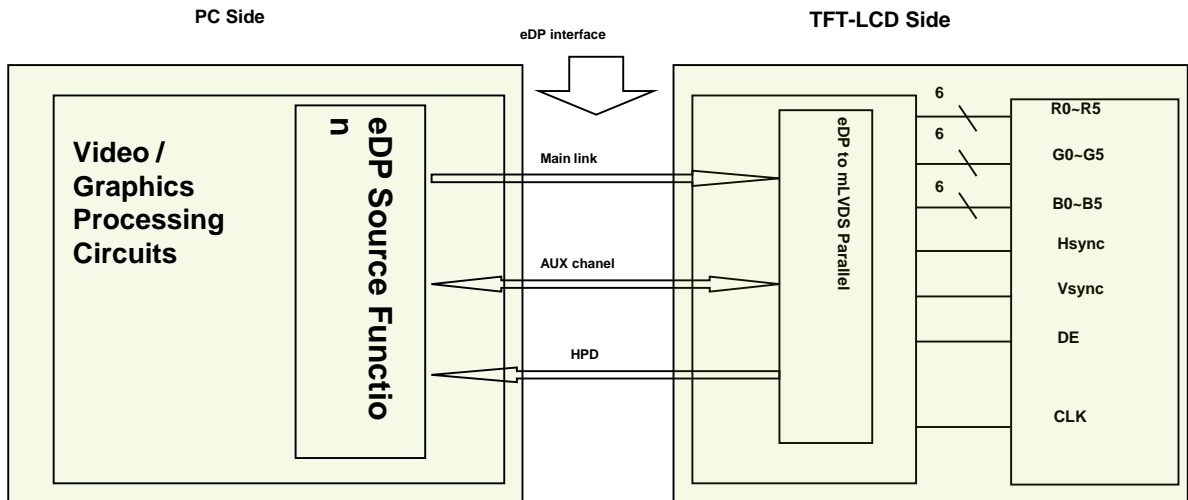

**Note. Transmitter : HX8876-LG4 or equivalent.  
Transmitter is not contained in Module.**

## 5.3.eDP Input signal

Lane 0	Lane 1
R0-5:0 G0-5:4	R1-5:0 G1-5:4
G0-3:0 B0-5:2	G1-3:0 B1-5:2
B0-1:0 R2-5:0	B1-1:0 R3-5:0
G2-5:0 B2-5:4	G3-5:0 B3-5:4
B2-3:0 R4-5:2	B3-3:0 R5-5:2
R4-1:0 G4-5:0	R5-1:0 G5-5:0
B4-5:0 R6-5:4	B5-5:0 R7-5:4
R6-3:0 G6-5:2	R7-3:0 G7-5:2
R6-1:0 G6-5:0	R7-1:0 G7-5:0

## 5.4 Back-light & LCM Interface Connection

BLU Interface Connector: STM MSK24022P10 or Compatible.

<Table 7. Pin Assignments for the BLU Connector>

Pin No.	Symbol	Description	Pin No.	Symbol	Description
1	LED1	LED cathode connection	6	NC	No Connection
2	LED2	LED cathode connection	7	Vout	LED anode connection
3	LED3	LED cathode connection	8	Vout	LED anode connection
4	LED4	LED cathode connection	9	Vout	LED anode connection
5	NC	No Connection	10	Vout	LED anode connection

**6.0 SIGNAL TIMING SPECIFICATION****6.1 The 15.6车载 is operated by the DE only.**

Item		Symbols	Min	Typ	Max	Unit
Clock	Frequency	1/Tc	100	141.4	146	MHz
	High Time	Tch	-	-	-	Tc
	Low Time	Tcl	-	-	-	Tc
Frame Period		Tv	1090	1100	1238	lines
			-	60	-	Hz
			-	16.7	-	ms
Vertical Display Period		Tvd	-	1080	-	lines
One line Scanning Period		Th	2096	2142	2400	clocks
Horizontal Display Period		Thd	-	1920	-	clocks

Note※: This Module can support low frame refresh rate 50Hz & 40Hz.

## 6.2 eDP Rx Interface Timing Parameter

The specification of the eDP Rx interface timing parameter is shown in Table 8.

<Table 8. eDP Rx Interface Timing Specification>

Item	Symbol	Min	Typ	Max	Unit	Remark
Spread spectrum clock	ssc			0.5	%	
Differential peak-to-peak input voltage at package pins	VRX-DIFFp-p	$\pm 60$	0	$\pm 600$	mV	Pins are AC-coupled
Rx input DC common mode voltage	VRX_DC_CM	0	-	2.0	V	
Differential termination resistance	RRX-DIFF	90	100	110	$\Omega$	
Single-ended termination resistance	RRX-SE	45	50	55	$\Omega$	
Rx short circuit current limit	IRX_SHORT	-	-	20	mA	
Intra-pair skew at Rx package pins (HBR) RX intra-pair skew tolerance at HBR	LRX_SKEW_INTRA_PAIR	-	-	60	ps	

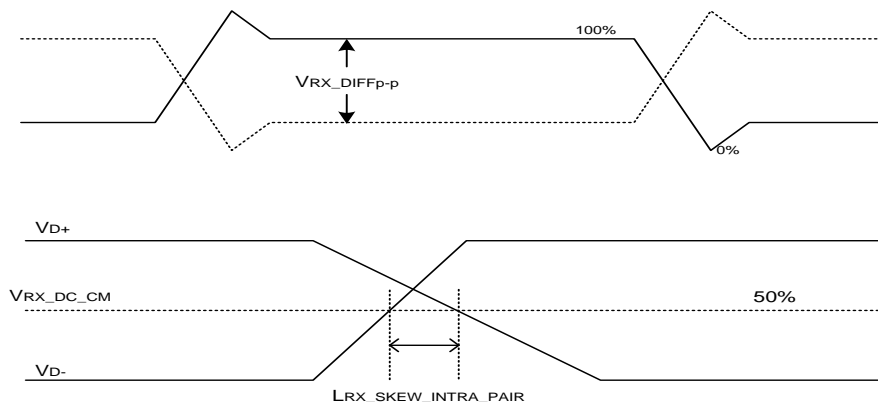

## 7.0 INPUT SIGNALS, BASIC DISPLAY COLORS &amp; GRAY SCALE OF COLORS

	Colors & Gray scale	Data signal																	
		R0	R1	R2	R3	R4	R5	G0	G1	G2	G3	G4	G5	B0	B1	B2	B3	B4	B5
Basic colors	Black	0	0	0	0	0	0	0	0	0	0	0	0	0	0	0	0	0	0
	Blue	0	0	0	0	0	0	0	0	0	0	0	0	1	1	1	1	1	1
	Green	0	0	0	0	0	0	1	1	1	1	1	1	0	0	0	0	0	0
	Light Blue	0	0	0	0	0	0	1	1	1	1	1	1	1	1	1	1	1	1
	Red	1	1	1	1	1	1	0	0	0	0	0	0	0	0	0	0	0	0
	Purple	1	1	1	1	1	1	0	0	0	0	0	0	1	1	1	1	1	1
	Yellow	1	1	1	1	1	1	1	1	1	1	1	1	0	0	0	0	0	0
White	1	1	1	1	1	1	1	1	1	1	1	1	1	1	1	1	1	1	
Gray scale of Red	Black	0	0	0	0	0	0	0	0	0	0	0	0	0	0	0	0	0	0
	△	1	0	0	0	0	0	0	0	0	0	0	0	0	0	0	0	0	0
	Darker	0	1	0	0	0	0	0	0	0	0	0	0	0	0	0	0	0	0
	△				↑						↑						↑		
	▽				↓						↓						↓		
	Brighter	1	0	1	1	1	1	0	0	0	0	0	0	0	0	0	0	0	0
▽	0	1	1	1	1	1	0	0	0	0	0	0	0	0	0	0	0	0	
Red	1	1	1	1	1	1	0	0	0	0	0	0	0	0	0	0	0	0	
Gray scale of Green	Black	0	0	0	0	0	0	0	0	0	0	0	0	0	0	0	0	0	0
	△	0	0	0	0	0	0	1	0	0	0	0	0	0	0	0	0	0	0
	Darker	0	0	0	0	0	0	0	1	0	0	0	0	0	0	0	0	0	0
	△				↑						↑						↑		
	▽				↓						↓						↓		
	Brighter	0	0	0	0	0	0	1	0	1	1	1	1	0	0	0	0	0	0
▽	0	0	0	0	0	0	0	1	1	1	1	1	0	0	0	0	0	0	
Green	0	0	0	0	0	0	1	1	1	1	1	1	0	0	0	0	0	0	
Gray scale of Blue	Black	0	0	0	0	0	0	0	0	0	0	0	0	0	0	0	0	0	0
	△	0	0	0	0	0	0	0	0	0	0	0	0	1	0	0	0	0	0
	Darker	0	0	0	0	0	0	0	0	0	0	0	0	0	1	0	0	0	0
	△				↑						↓						↑		
	▽				↓						↓						↓		
	Brighter	0	0	0	0	0	0	0	0	0	0	0	0	1	0	1	1	1	1
▽	0	0	0	0	0	0	0	0	0	0	0	0	0	1	1	1	1	1	
Blue	0	0	0	0	0	0	0	0	0	0	0	0	1	1	1	1	1	1	
Gray scale of White & Black	Black	0	0	0	0	0	0	0	0	0	0	0	0	0	0	0	0	0	0
	△	1	0	0	0	0	0	1	0	0	0	0	0	1	0	0	0	0	0
	Darker	0	1	0	0	0	0	0	1	0	0	0	0	0	1	0	0	0	0
	△				↑						↑						↑		
	▽				↓						↓						↓		
	Brighter	1	0	1	1	1	1	1	0	1	1	1	1	1	0	1	1	1	1
▽	0	1	1	1	1	1	0	1	1	1	1	1	0	1	1	1	1	1	
White	1	1	1	1	1	1	1	1	1	1	1	1	1	1	1	1	1	1	

## 8.0 POWER SEQUENCE

To prevent a latch-up or DC operation of the LCD module, the power on/off sequence shall be as shown in below

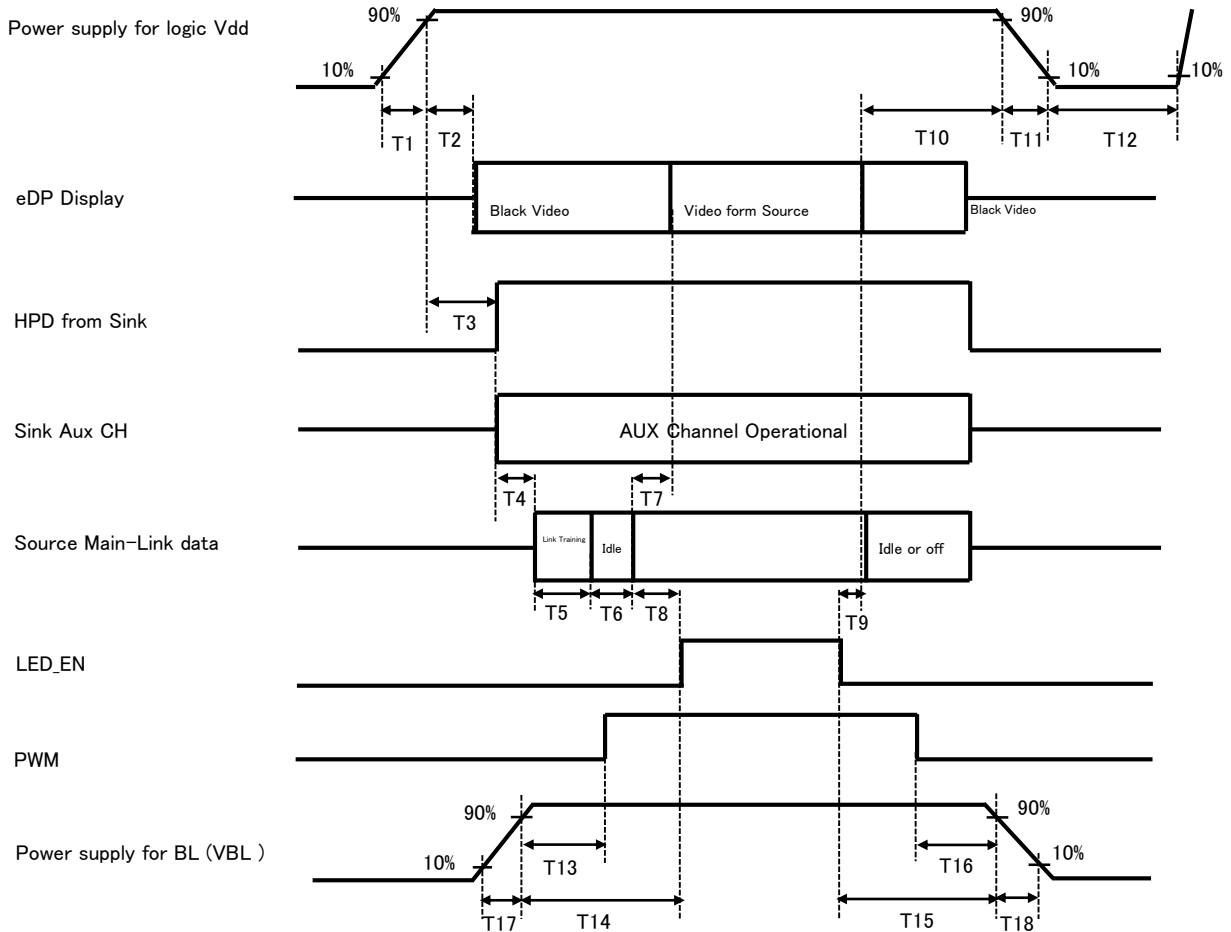

- $0.5\text{ms} \leq T1 \leq 10\text{ms}$
- $0\text{ms} \leq T2 \leq 200\text{ms}$
- $0\text{ms} \leq T3 \leq 200\text{ms}$
- $0\text{ms} \leq T13$
- $0\text{ms} \leq T14$
- $0\text{ms} \leq T17$

- $0\text{ms} \leq T7 \leq 50\text{ms}$
- $0\text{ms} \leq T10 \leq 500\text{ms}$
- $0\text{ms} \leq T11 \leq 10\text{ms}$
- $150\text{ms} \leq T12$
- $0\text{ms} \leq T15$
- $0\text{ms} \leq T16$
- $0\text{ms} \leq T18$

### Notes:

1. When the power supply VDD is 0V, keep the level of input signals on the low or keep high impedance.
2. Do not keep the interface signal high impedance when power is on. Back Light must be turn on after power for logic and interface signal are valid.

SPEC. NUMBER

PRODUCT GROUP

REV.

ISSUE DATE

PAGE

TFT- LCD

P0

2020.07.03

20 OF 31

## 9.0 Connector Description

Physical interface is described as for the connector on LCM.

These connectors are capable of accommodating the following signals and will be following components.

### 9.1 TFT LCD Module

Connector Name /Description	For Signal Connector
Manufacturer	STM or Compatible
Type/ Part Number	MSAK24025P30 or Compatible
Mating Housing/ Part Number	MSK24022P10 or Compatible

**10.0 MECHANICAL CHARACTERISTICS****10.1 Dimensional Requirements**

FIGURE 6 shows mechanical outlines for the model AV156FHB-N10.  
Other parameters are shown in Table 9.

&lt;Table 9. Dimensional Parameters&gt;

Parameter	Specification	Unit
Active Area	344.16 (H) × 193.59(V)	
Number of pixels	1920 (H) X 1080 (V) (1 pixel = R + G + B dots)	
Pixel pitch	0.17925 (H) X 0.17925 (V)	mm
Pixel arrangement	RGB Vertical stripe	
Display colors	262K	
Display mode	Normally Black	
Dimensional outline	359.5(H)*223.75(V) (W/PCB)*3.3(Max)	mm
Weight	TBD	gram

**10.2 Mounting**

See FIGURE 6.

**10.3 Anti-Glare and Polarizer Hardness.**

The surface of the LCD has an AG coating to minimize reflection and a coating to reduce scratching.

**10.4 Light Leakage**

There shall not be visible light from the back-lighting system around the edges of the screen as seen from a distance 50cm from the screen with an overhead light level of 350lux.

**11.0 RELIABILITY TEST**

The Reliability test items and its conditions are shown in below.

<Table 10. Reliability test>

No	Test Items	Conditions
1	High temperature storage test	Ta = 60 °C, 240 hrs
2	Low temperature storage test	Ta = -20 °C, 240 hrs
3	High temperature & high humidity operation test	Ta = 50 °C, 80%RH, 240 hrs
4	High temperature operation test	Ta = 50 °C, 240 hrs
5	Low temperature operation test	Ta = 0 °C, 240 hrs
6	Thermal shock	Ta = -20 °C ↔ 60 °C (0.5 hr), 100 cycle
7	Vibration test (non-operating)	1.5G, 10~500Hz, Half Sine X,Y,Z / Sweep rate : 1 hour
8	Shock test (non-operating)	220G, Half Sine Wave 2msec ±X, ±Y, ±Z Once for each direction
9	Electro-static discharge test (non-operating)	Air : 150 pF, 330Ω, 15 KV Contact : 150 pF, 330Ω, 8 KV
10	Image Sticking	25degC 1 hr, 6*8chess pattern, @L127 grey scale, Couldn't detect any image sticking after 5 seconds

**12.0 HANDLING & CAUTION**

## (1) Cautions when taking out the module

- Pick the pouch only, when taking out module from a shipping package.

## (2) Cautions for handling the module

- As the electrostatic discharges may break the LCD module, handle the LCD module with care. Peel a protection sheet off from the LCD panel surface as slowly as possible.
- As the LCD panel and back - light element are made from fragile glass material, impulse and pressure to the LCD module should be avoided.
- As the surface of the polarizer is very soft and easily scratched, use a soft dry cloth without chemicals for cleaning.
- Do not pull the interface connector in or out while the LCD module is operating.
- Put the module display side down on a flat horizontal plane.
- Handle connectors and cables with care.

## (3) Cautions for the operation

- When the module is operating, do not lose CLK, ENAB signals. If any one of these signals is lost, the LCD panel would be damaged.
- Obey the supply voltage sequence. If wrong sequence is applied, the module would be damaged.

SPEC. NUMBER	PRODUCT GROUP TFT- LCD	REV. P0	ISSUE DATE 2020.07.03	PAGE 23 OF 31	

- (4) Cautions for the atmosphere
- Dew drop atmosphere should be avoided.
  - Do not store and/or operate the LCD module in a high temperature and/or humidity atmosphere. Storage in an electro-conductive polymer packing pouch and under relatively low temperature atmosphere is recommended.
- (5) Cautions for the module characteristics
- Do not apply fixed pattern data signal to the LCD module at product aging.
  - Applying fixed pattern for a long time may cause image sticking.
- (6) Other cautions
- Do not disassemble and/or re-assemble LCD module.
  - Do not re-adjust variable resistor or switch etc.
  - When returning the module for repair or etc., Please pack the module not to be broken. We recommend to use the original shipping packages.

**13.0 LABEL**

(1) MDL label

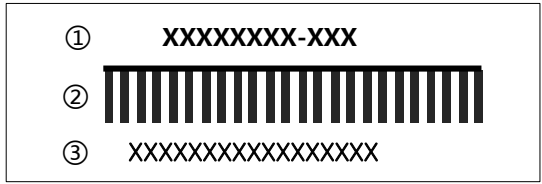

序列号标注部分需打印, 说明如下:

- 1.FG-CODE(前12位)
  - 2.产品 ID条形码
  - 3.产品 ID
- Total Size:35\*6mm

Digit	1	2	3	4	5	6	7	8	9	10	11	12	13	14	15	16	17
Code	S	L	S	5	1	2	3	5	9	4	2	0	0	0	1	D	B
Description	Model Code/GBN		Grade	Line	Year		Month	Model Extension Code (Last 4 Digits Of FG-Code)				Serial Number:00001~ZZZZZZ					

产品 ID编码规则

## (2) Box label

HF XINSHENG OPTOELECTRONICS TECHNOLOGY Co., LTD

MODEL:      XXXXXXXX-XXX ①      Q'TY:      XX      ②

SERIAL NO:    XXXXXXXXXXXXX ③      DATE:    XXXX/XX/XX ④

Box ID bar code

XXXX-XXXXXX ⑤      XXXX ⑥      XXXXX ⑦      (QA)

序列号标注部分需打印, 说明如下:

1. FG-CODE(前12位)
2. 产品数量
3. Box ID
4. 包装日期
5. 客户端物料号(客户端)
6. FG-Code后四位
7. 供应商代码

Total Size:110×55mm

Digit	1	2	3	4	5	6	7	8	9	10	11	12	13
Code	S	L	S	5	1	2	3	D	0	0	0	6	8
Description	Products/GBN		Grade	Line	Year		Month	Revision Code	Serial Number				

Box ID编码规则

**14.0 PACKING INFORMATION****14.1 Packing order**

1-将1pcs OC 放入Tray中（显示面朝上），然后放置1pcs EPE Spacer

-容量:1pcs OC /Tray

2-堆叠放置20pcs Tray，顶部再放置1pcs 空Tray

-将21pcs PET Tray 平放入Shielding Bag进行抽真空，建议热封两道，防止一道热封不良

3-在Inner Box放置1pcs EPE Cover，将堆叠好的21pcs Tray平放入Box

-再放置1pcs EPE Board，封箱

- 容量：20pcs OC/Box

4-每个Pallet上放3层Box，1层4箱,共计12ea Box

-Pallet外进行缠膜包装

-240 pcs OC/Pallet

**14.2 Notes**

- Box Dimension: 496mm×396mm×290mm
- Package Quantity in one Box:20pcs

15.0 MECHANICAL OUTLINE DIMENSION

Figure 6. TFT-LCD Module Outline Dimension (Front View)

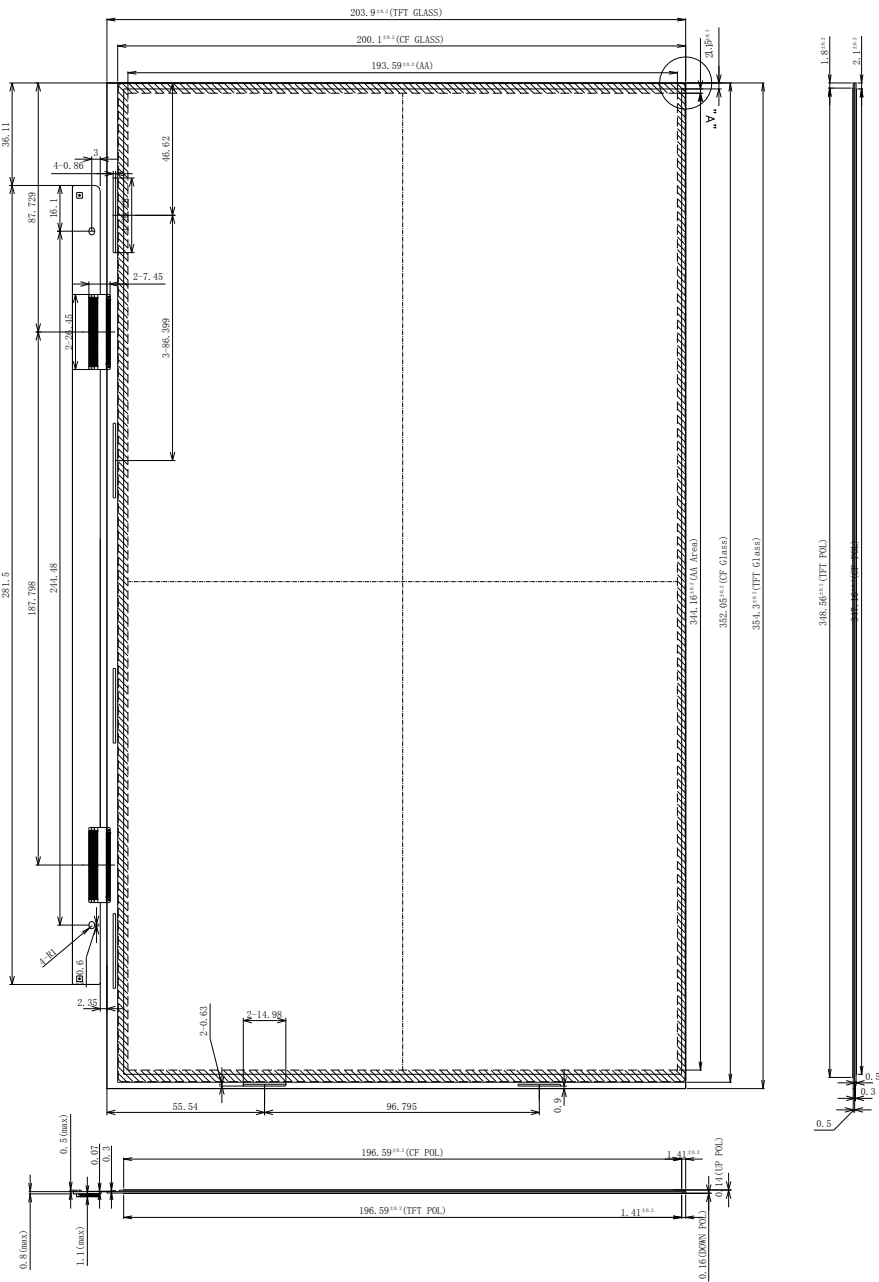



Date:	Page: 1/1	THE THIRD ANGLE	Customer Code.:	EDITION: 01
			CUSTOMER'S P/N:	FX'S P/N: (include wrapper)
			FX'S P/N(exclude wrapper):	Approval (核准)
				Check (检查)
				Design (设计)

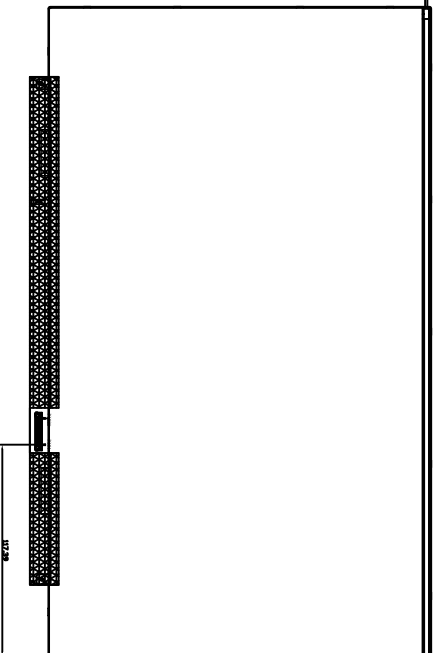
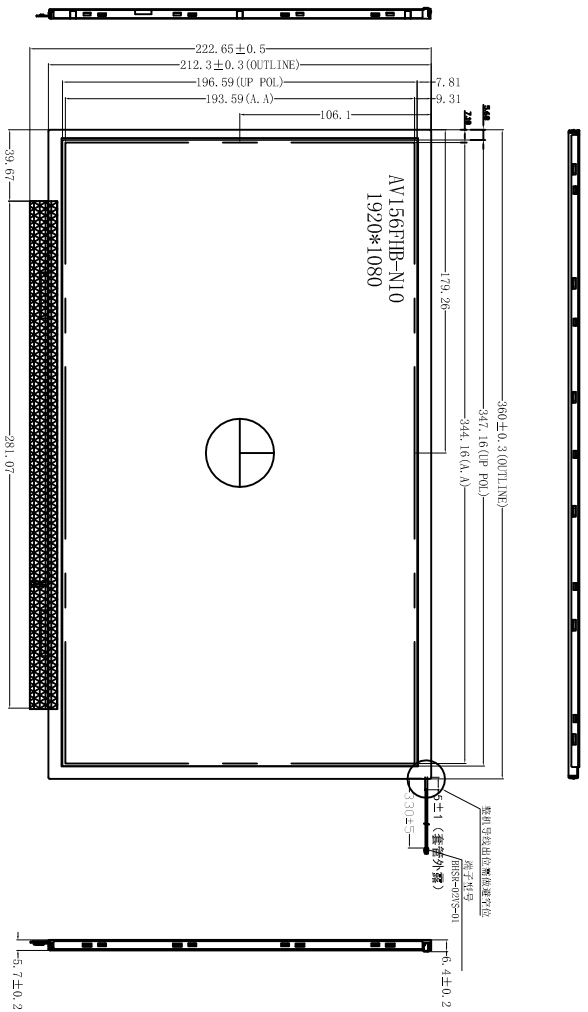

- Notes:
- Unit:mm. IF= 360mA, 亮度1000-1100
  - Do not scale drawing. IF= 380mA, 亮度1100-1150
  - All radii without dimension R0.2. IF= 400mA, 亮度1150-1200
  - Modification Mark. IF= 420mA, 亮度1200-1300
  - draft angle: 1°
  - Backlight luminance :模组1000cd/m<sup>2</sup>(TYP)
  - Luminance uniformity: 75% (min) (min/max\*100%)
  - Unspecified Tolerance is ±0.2
  - Operation conditions : IF= 360mA (TYP) 420mA (MAX), VF=33-36V (MAX)
  - Color coordinate:X=0.27-0.35, Y=0.27-0.35 (模组)
  - All materials comply with RoHS
  - The measured value of luminance and color coordinate bases FX' s BM-7
  - Check item: 1~9

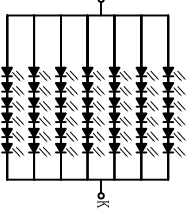

Backlight LED Circuit

REV	DATE	DESCRIPTION (修改内容)	REVISER	NO.	TITLE	Quantity
12		Front iron Frame (上铁框)		1		1
11		PPC (印制电路板)		0		0
10		Double sided stick (双面胶)		2		2
9		HOUSING (塑胶框)		1		1
8		PCB(印制电路板)		1		1
7		Wire (导线)		1		1
6		LED (发光二极管)		42		42
5		BEF(薄片)		2		2
4		Diffuser film(扩散片)		1		1
3		Light guide plate (导光板)		1		1
2		Reflector film (反射膜)		1		1
1		Rear iron frame (下铁框)		1		1

Customer:	Approval Date:	Approve by:
客户:	确认日期:	确认

**16.0 EDID Table**

Address (HEX)	Function	Hex	Dec	crc	Input values.	Notes
00	Header	00	0		0	EDID Header
01		FF	255		255	
02		FF	255		255	
03		FF	255		255	
04		FF	255		255	
05		FF	255		255	
06		FF	255		255	
07		00	0		0	
08	ID Manufacturer Name	09	9		BOE	ID = BOE
09		E5	229			
0A	ID Product Code	32	50		1586	ID = 1586
0B		06	6			
0C	32-bit serial No.	00	0			
0D		00	0			
0E		00	0			
0F		00	0			
10	Week of manufacture	01	1		1	
11	Year of Manufacture	19	25		2015	Manufactured in 2015
12	EDID Structure Ver.	01	1		1	EDID Ver 1.0
13	EDID revision #	04	4		4	EDID Rev. 0.4
14	Video input definition	95	149		-	
15	Max H image size	22	34		34	34 cm (Approx)
16	Max V image size	13	19		19	19 cm (Approx)
17	Display Gamma	78	120		2.2	Gamma curve = 2.2
18	Feature support	0A	10			RGB display, Preferred Timming mode
19	Red/Green low bits	49	73		-	Red / Green Low Bits
1A	Blue/White low bits	50	80		-	Blue / White Low Bits
1B	Red x high bits	A4	164	657	0.642	Red (x) = 10100100 (0.642)
1C	Red y high bits	58	88	352	0.344	Red (y) = 01011000 (0.344)
1D	Green x high bits	51	81	326	0.319	Green (x) = 01010001 (0.319)
1E	Green y high bits	9C	156	625	0.611	Green (y) = 10011100 (0.611)
1F	Blue x high bits	26	38	153	0.15	Blue (x) = 00100110 (0.15)
20	Blue y high bits	0B	11	45	0.044	Blue (y) = 00001011 (0.044)
21	White x high bits	50	80	320	0.313	White (x) = 01010000 (0.313)
22	White y high bits	54	84	336	0.329	White (y) = 01010100 (0.329)
23	Established timing 1	00	0		-	
24	Established timing 2	00	0		-	

SPEC. NUMBER	PRODUCT GROUP	REV.	ISSUE DATE	PAGE
	TFT- LCD	P0	2020.07.03	29 OF 31

Address (HEX)	Function	Hex	Dec	crc	Input values.	Notes
25	Established timing 3	00	0		-	
26	Standard timing #1	01	1			Not Used
27		01	1			
28	Standard timing #2	01	1			Not Used
29		01	1			
2A	Standard timing #3	01	1			Not Used
2B		01	1			
2C	Standard timing #4	01	1			Not Used
2D		01	1			
2E	Standard timing #5	01	1			Not Used
2F		01	1			
30	Standard timing #6	01	1			Not Used
31		01	1			
32	Standard timing #7	01	1			Not Used
33		01	1			
34	Standard timing #8	01	1			Not Used
35		01	1			
36	Detailed timing/monit or descriptor #1	99	153		139.78	139.776MHz Main clock
37		36	54			
38		80	128		1920	Hor Active = 1920
39		A0	160		160	Hor Blanking = 160
3A		70	112		-	4 bits of Hor. Active + 4 bits of Hor. Blanking
3B		38	56		1080	Ver Active = 768
3C		28	40		40	Ver Blanking = 40
3D		40	64		-	4 bits of Ver. Active + 4 bits of Ver. Blanking
3E		30	48		48	Hor Sync Offset = 48
3F		20	32		32	H Sync Pulse Width = 32
40		36	54		3	V sync Offset = 3 line
41		00	0		6	V Sync Pulse width : 6 line
42		58	88		344	Horizontal Image Size = 344 mm (Low 8 bits)
43		C2	194		194	Vertical Image Size = 194 mm (Low 8 bits)
44		10	16		-	4 bits of Hor Image Size + 4 bits of Ver Image Size
45		00	0		0	Hor Border (pixels)
46		00	0		0	Vertical Border (Lines)
47	1A	26			Refer to right table	

--	--	--	--	--

SPEC. NUMBER	PRODUCT GROUP TFT- LCD	REV. P0	ISSUE DATE 2020.07.03	PAGE 30 OF 31
--------------	---------------------------	------------	--------------------------	------------------

Address (HEX)	Function	Hex	Dec	crc	Input values	Notes
48	Detailed timing/mo nitor descriptor #2	AE	174		111.82	111.8208MHz Main clock
49		2B	43			
4A		80	128		1920	Hor Active = 1920
4B		A0	160		160	Hor Blanking = 160
4C		70	112		-	4 bits of Hor. Active + 4 bits of Hor. Blanking
4D		38	56		1080	Ver Active = 768
4E		28	40		40	Ver Blanking = 40
4F		40	64		-	4 bits of Ver. Active + 4 bits of Ver. Blanking
50		30	48		48	Hor Sync Offset = 48
51		20	32		32	H Sync Pulse Width = 32
52		36	54		3	V sync Offset = 3 line
53		00	0		6	V Sync Pulse width : 6 line
54		58	88		344	Horizontal Image Size = 344 mm (Low 8 bits )
55		C2	194		194	Vertical Image Size = 194 mm (Low 8 bits)
56		10	16		-	4 bits of Hor Image Size + 4 bits of Ver Image Size
57		00	0		0	Hor Border (pixels)
58		00	0		0	Vertical Border (Lines)
59	1A	26				
5A	Detailed timing/mo nitor descriptor #3	00	0			ASCII Data Sting Tag
5B		00	0			
5C		00	0			
5D		FE	254			
5E		00	0			
5F		56	86		V	D/PN: VMX8X
60		4D	77		M	
61		58	88		X	
62		38	56		8	EDID:A00
63		58	88		X	
64		80	128		10000000	
65		4E	78		N	
66		56	86		V	
67	31	49		1		
68	35	53		5		
69	4E	78		N		
6A	34	52		4	BOE PN	
6B	33	51		3		

SPEC. NUMBER

PRODUCT GROUP

REV.

ISSUE DATE

PAGE

TFT- LCD

P0

2020.07.03

31 OF 31

Address (HEX)	Function	Hex	Dec	crc	Input values.	Notes
6C	Detailed timing/monitor descriptor #4	00	0			Product Name Tag (ASCII)
6D		00	0			
6E		00	0			
6F		00	0			
70		00	0			
71		00	0		00000000	
72		41	65		01000001	WLED & single light bar & one light bar
73		11	17		00010001	Frame rate 40Hz~65Hz
74		96	150		10011110	Light Controller:PWM & Max. Luminance 300
75		00	0		00000000	Front Surface:Anti-Glare& RGB v-stripe
76		00	0		00010000	with DBC
77		00	0		00000000	no Motion Blur & no Active Gamma
78		00	0		00000000	no Wireless Enhancement & no In-Cell Scanner
79		0A	10		00001010	2 Lane edp1.3
7A		01	1		00000001	Built-In Self Test
7B		0A	10			
7C	20	32				
7D	20	32				
7E	Extension flag	00	0			
7F	Checksum	6D	109	109	-	