

规格书

Product Specification

客户名称 Customer	
客户项目号 Part NO	
产品型号 Part NO	H0102Y006-V0
产品内容 Product type	Mode:Transmissive type .Normally black. TFTLCD Module LCD Module: 1.02"128RGB*115Dot 圆 4SPI
客户确认签章 Signature by Customer:	

PREPARED BY	CHECKED BY	APPROVED BY

Table of Contents 目录

1	General Description 规格简介.....	4
2	Module Parameter 模组参数.....	4
3	Mechanical Drawings 结构图.....	5
4	Module Interface 模组接口定义.....	6
5	Application Circuit 应用电路.....	6
6	Absolute Maximum Ratings 绝对最大额定值.....	7
7	Electrical Specification 电性规格.....	7
8	Initialization Code 初始化代码.....	8
9	Optical Specifications 光学规格.....	8
9.1	Optical Specifications 光学规格.....	8
9.2	The power on/off sequence is illustrated below 电源启动/关闭顺序.....	9
9.3	Definition of Contrast Ratio 对比度的定义.....	9
9.4	Definition of Viewing Angles 视角的定义.....	10
9.5	Definition of Color Appearance 色域的定义.....	10
9.6	Definition of Surface Luminance, Uniformity and Transmittance.....	10
	表面亮度、均匀性和透光率的定义.....	10
10	Quality Assurance 质量标准.....	14
10.1	Purpose 目的.....	11
10.2	Agreement Items 协议项目.....	11
10.3	Standard of the Product Visual Inspection 产品外观检验标准.....	11
10.4	Inspection Specification 检验标准.....	11
10.5	Classification of Defects 缺陷的分类.....	16
10.6	Identification/marketing criteria 识别/评分标准.....	16
10.7	Packing 包装.....	16
11	Reliability Specification 可靠性规范.....	16
12	Precautions and Warranty 注意事项和保证.....	17
12.1	Safety 安全.....	17
12.2	Handling 处理.....	17
12.3	Operation 操作.....	17
12.4	Static Electricity 静电.....	17
12.5	Limited Warranty 有限质量保证.....	17
13	Packaging 包装.....	17
14	Prior Consult Matter 免责声明.....	18

1 General Description 规格简介

This display module is a transmissive type color active matrix TFT(Thin Film Transistor) liquid crystal display (LCD) that uses amorphous silicon TFT as a switching device. This module is composed of a TFT LCD module, a driver circuit, and a back-light unit. The resolution of a 1.02" contains 128RGB x 115 dots and can display up to 262K colors.

该显示模块是一种采用非晶硅 TFT 作为开关器件的透射型彩色有源矩阵 TFT(薄膜晶体管)液晶显示器。该模块由 TFT 液晶显示模块、驱动电路和背光单元组成。1.02 英寸的分辨率包含 128RGB x 115 点，可显示高达 262K 的颜色。

2 Module Parameter 模组参数

Features	Details	Unit
Display Size(Diagonal) 显示尺寸(对角线)	1.02	inch
LCD type 液晶显示屏类型	α -Si TFT	-
Display Mode 显示模式	IPS / Transmissive / Normally Black	-
Resolution 分辨率	128RGB x 115	-
Active Area 显示区	24.36(H) \times .21.89(V)	mm
Module Outline 模组外形	26.71(H) \times 26.22(V) \times 1.86(T)	mm
Display Colors 显示颜色	262K	-
Interface 接口	4SPI	-
Driver IC 驱动 IC	GC9107	-
TP Viewing Area TP 视窗	-	mm
TP Outline(assembly) TP 外形	-	mm
Luminance on surface 亮度	400	cd/m ²
View Direction 视角方向	All	Best image
Contrast ratio 对比度	1200:1	
Color gamut 色域	70%	
PPI 图像点密集度	133	-
Window effect 视窗效果	无一体黑	-
Cover plate surface effect 盖板表面效果	无 AF/AG	-
Operating Temperature 工作温度	-20~60	°C
Storage Temperature 储存温度	-30~70	°C
Weight 重量	TBD	g
对应连接器	OK-F501-12325	

Note 1: Excluding hooks, posts , FPC/FPC tail etc.

3 Mechanical Drawings 结构图

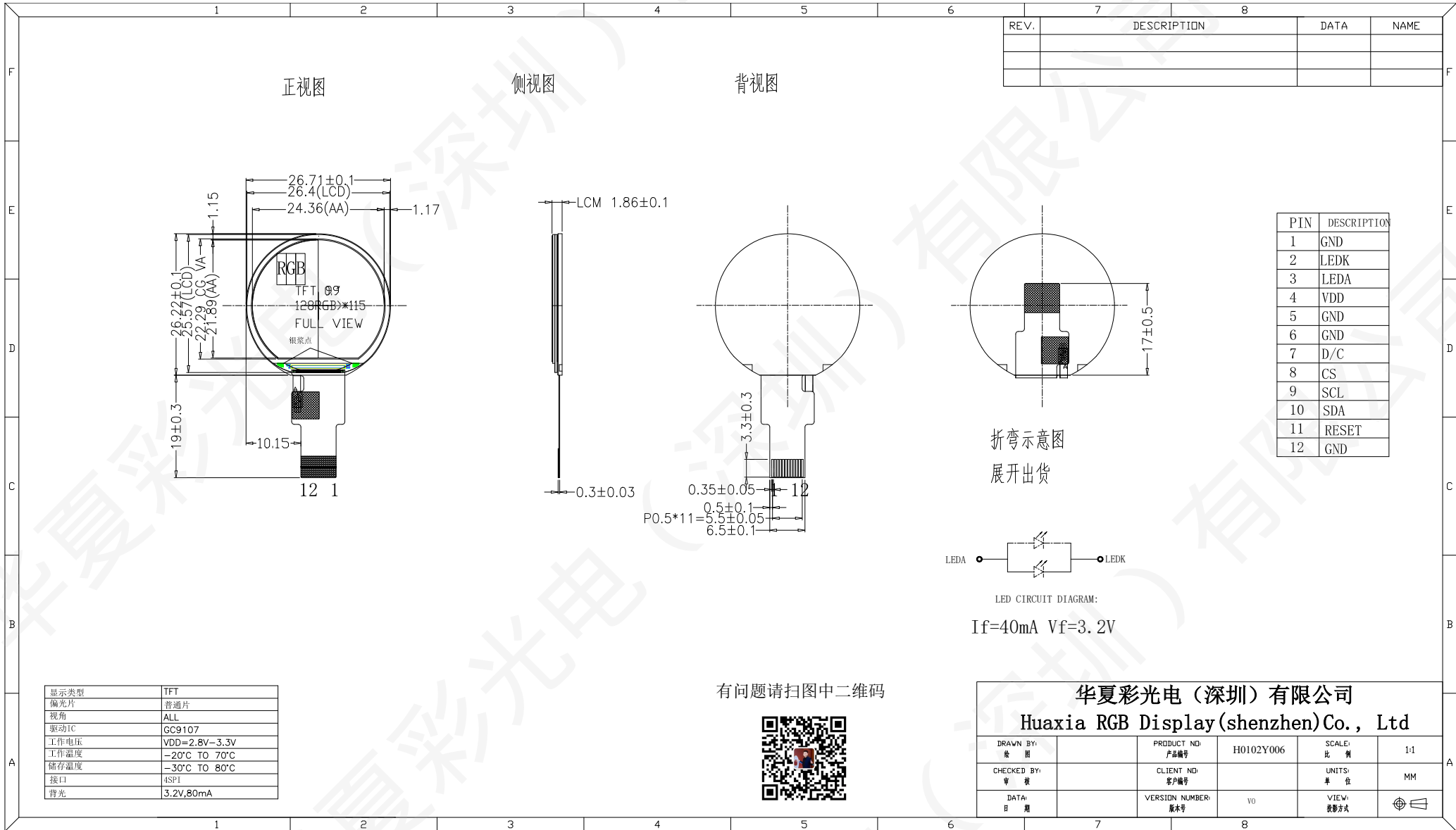

4 Module Interface 模组接口定义

NO	SYMBOL	FUNCTION
1	GND	Power Ground
2	LEDK	LED Cathode
3	LEDA	LED Anode
4	VDD	Power Supply for Analog, VCC=2.5V~3.3V
5	GND	Power Ground
6	GND	Power Ground
7	D/C	Display data/command Selection Pin in MCU Interface
8	CS	Chip Selection Pin
9	SCL	Serial Clock Signal
10	SDA	Serial Data Input
11	RESET	This signal will reset the device and it must be applied to properly initialize the chip.
12	GND	Power Ground

5 Application Circuit 应用电路

5.1 Backlight recommended circuit 背光电路参考

Motherboard driver backlight is need constant current circuit, if the rated voltage screen after light brightness difference. Current and power consumption of the machine are inconsistent, so recommend a backlight driving circuit is best rated current. It is recommended to use IC (AW9364). The reference circuit is as follows:

5.2 Backlight recommended circuit 背光电路参数推荐

Motherboard driver backlight is need constant current circuit:

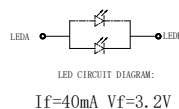

2 灯并联

Note: constant current circuit for every LED, and though LED lamp current is less than 20mA. Recommend between 15mA and 20 mA for every LED.

6 Absolute Maximum Ratings 绝对最大额定值

VSS=0V, Ta=25°C

Item 项目	Symbol	Min.最小	Max.最大	Unit 单位	
Supply Voltage 电源电压	Power supply 电力供应	VDD	-0.3	+4.6	V
	Analog 模拟	-	-	-	V
	IO	IOVDD	-0.3	+4.6	V
Input Voltage 输入电压	V_i	-0.3	IOVDD+0.3	V	
Storage temperature 储存温度	T_{stg}	-30	+70	°C	
Operating temperature 工作温度	T_{op}	-20	+60	°C	
Storage humidity 存储湿度	H_{stg}	10	Note 1	%RH	
Operating humidity 操作湿度	H_{op}	10	Note 1	%RH	

Note 1: 90%RH max, If Ta is below 50°C; 60%RH max, If Ta is over 60°C.

7 Electrical Specification 电性规格

DC Characteristics 直流特性

Item 项目	Symbol	Min.最小	Typ.中间	Max.最大	Unit 单位
Supply Voltage 电源电压	Powersupply 电力供应 VDD	2.4	2.8	3.3	V
	Analog VCI	2.4	2.8	3.3	V
	IO IOVDD	1.65	1.8/2.8	3.3	V
Logic Low input voltage 输入电压低	V _{IL}	-0.3IOVDD	-	0.3IOVDD	V
Logic High input voltage 输入电压高	V _{IH}	0.7IOVDD	-	IOVDD	V
Logic Low output voltage 输出电压低	V _{OL}	-	-	0.2IOVDD	V
Logic High output voltage 输出电压高	V _{OH}	0.8IOVDD	-	-	V
Current Consumption 电流消耗	Normal display 正常的显示 Ivdd	-	-	-	mA
	Standby mode 待机模式 Ivdd	-	-	-	uA
Frame Frequency 帧频	f _{FR}	-	60	-	Hz

8 Initialization Code 初始化代码

9 Optical Specifications 光学规格

9.1 Optical Specifications 光学规格

Ta=25°C, VDD=2.8V, TN LC+ Polarizer

On	Item 项目	Symbol 标志	Condition 条件	Specification 规范			Unit 单位
				Min. 最小	Typ. 中间	Max. 最大	
acklight	Luminance on surface(I _f =20mA) 表面亮度	L _v	Normally viewing angle		400	-	cd/m ²
	Contrast ratio 对比度	CR	θ _x =θ _y =0°	900	1200	-	-

Response time 响应时间		<i>TR</i>	-	10	15	ms	
		<i>TF</i>	-	20	20		
Chromaticity Transmissive 色度	Red 红	<i>XR</i>	-	0.614	0.634	0.654	-
		<i>YR</i>	-	0.318	0.338	0.358	-
	Green 绿	<i>XG</i>	-	0.276	0.296	0.316	-
		<i>YG</i>	-	0.552	0.572	0.592	-
	Blue 蓝	<i>XB</i>	-	0.114	0.134	0.154	-
		<i>YB</i>	-	0.107	0.127	0.147	-
	White 白	<i>XW</i>	-	0.296	0.316	0.336	-
		<i>YW</i>	-	0.325	0.345	0.365	-
Viewing Angle 视角	Horizo ntal	$\theta X+$	Center $CR \geq 10$	80	85	-	Deg.
		$\theta X-$		80	85	-	
	Vertical	$\theta Y+$		80	85	-	
		$\theta Y-$		80	85	-	
NTSC Ratio(Gamut)		-	-	65	70	-	%

9.2 The power on/off sequence is illustrated below 电源启动/关闭顺序

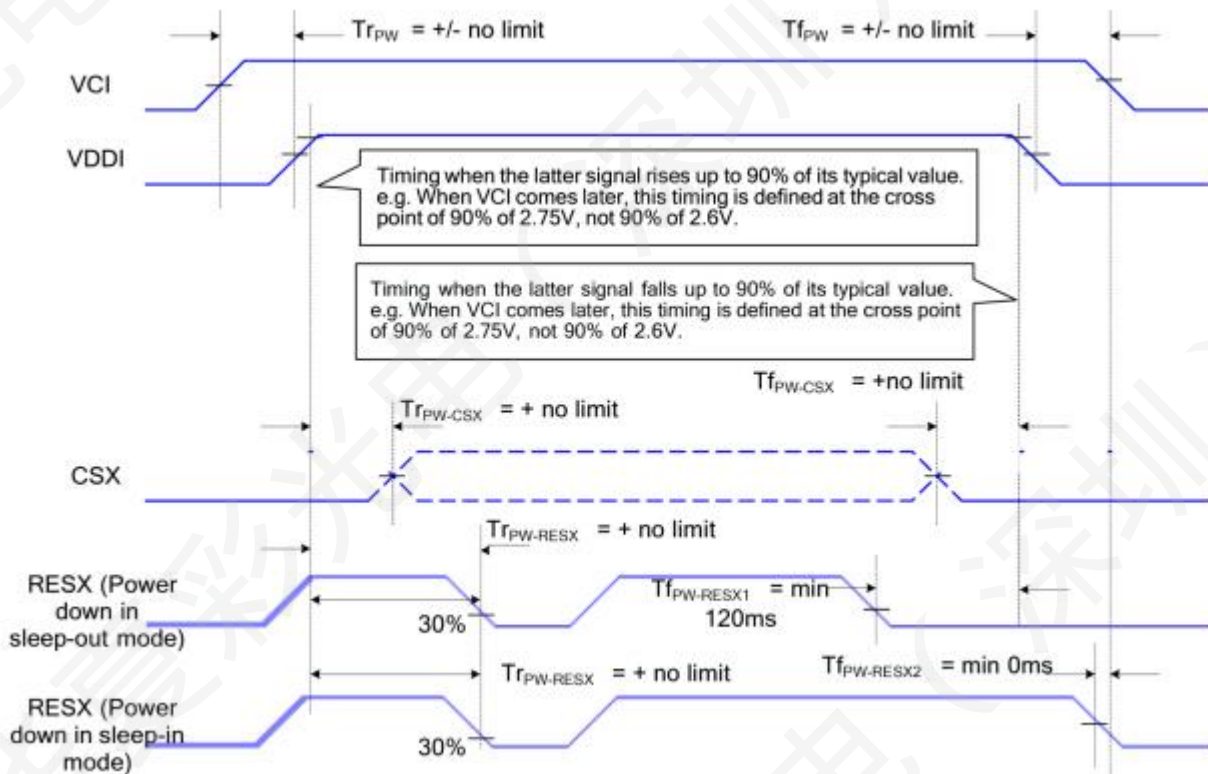

9.3 Definition of Contrast Ratio 对比度的定义

Contrast is measured perpendicular to display surface in reflective and transmissive mode. The measurement condition is:

Measuring Equipment 测量设备	BM-7 or EQUI
Measuring Point Diameter 测点直径	3mm//1mm
Measuring Point Location 测点位置	Active Area centre point
Test pattern 测试模式	A: All Pixels white

	B: All Pixel black
Contrast setting	Maximum

Definitions: CR (Contrast) = Luminance of White Pixel / Luminance of Black Pixel

9.4 Definition of Viewing Angles 视角的定义

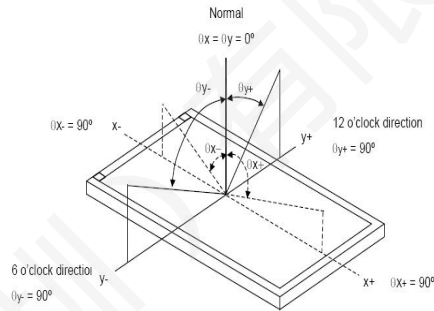

Measuring machine: LCD-5100 or EQUI

9.5 Definition of Color Appearance 色域的定义

R,G,B and W are defined by (x, y) on the IE chromaticity diagram

NTSC=area of RGB triangle/area of NTSC triangleX100%

Measuring picture: Red, Green, Blue and White (Measuring machine: BM-7)

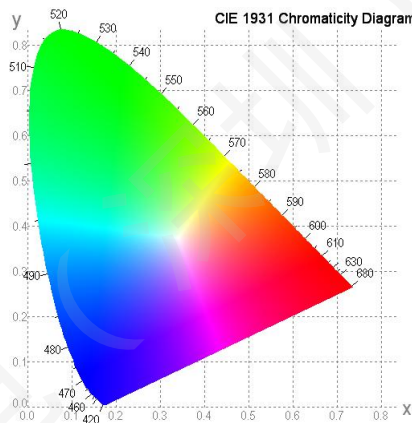

9.6 Definition of Surface Luminance, Uniformity and Transmittance

表面亮度、均匀性和透光率的定义

Using the transmissive mode measurement approach, measure the white screen luminance of the display panel and backlight.

9.6.1 Surface Luminance: LV = average (LP1:LP5)

9.6.2 Uniformity = Minimal (LP1:LP5) / Maximal (LP1:LP5) * 100%

9.6.3 Transmittance = LV on LCD / LV on Backlight * 100%

Note :Measuring machine:BM-7

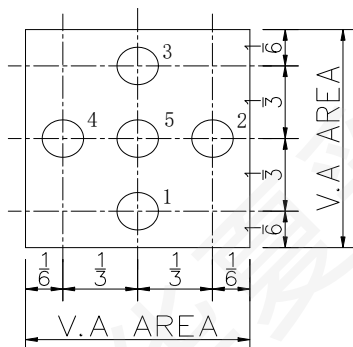

10 Quality Assurance 质量标准

10.1 Purpose 目的

This standard for Quality Assurance assures the quality of LCD module products supplied to customer by HuaXia RGB Display.

10.2 Agreement Items 协议项目

HuaXia RGB Display and customer shall negotiate if the following situation occurs:

10.2.1 Discrepancies between HuaXia RGB Display's QA standards and customer's QA standards.

10.2.2 Additional requirement to be added in product specification.

10.2.3 Any other special problem.

10.3 Standard of the Product Visual Inspection 产品外观检验标准

10.3.1 Appearance inspection:

10.3.1.1 The inspection must be under illumination about 1000 – 1500 lx, and the distance of view must be at 30cm ± 2cm.

10.3.1.2 The viewing angle should be 45° from the vertical line without reflection light or follows customer's viewing angle specifications.

10.3.1.3 Definition of area: A Zone: Active Area, B Zone: Viewing Area.

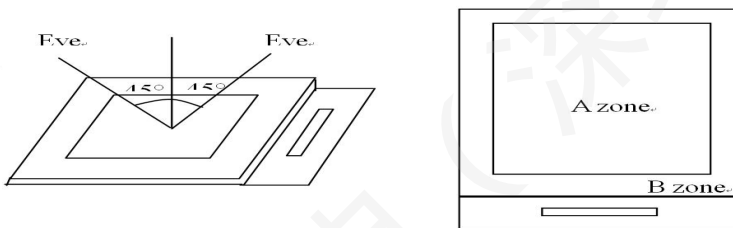

10.3.2 Basic principle: A set of sample to indicate the limit of acceptable quality level must be discussed by both HuaXia RGB Display and customer when there is any dispute happened.

10.4 Inspection Specification 检验标准

Sampling plan according to GB/T2828.1-2012/ISO 2859-1: 1999 and ANSI/ASQC

Z1.4-1993, normal level 2 and based on:



Major defect: AQL 0.4

Minor defect: AQL 1.0

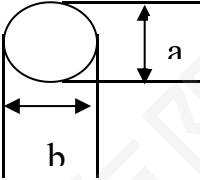
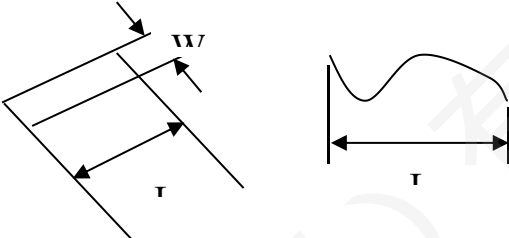
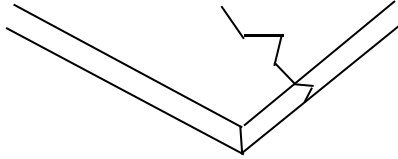
No.	Item 项目	Criteria (Unit: mm) 标准
-----	---------	------------------------

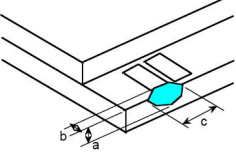
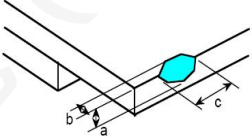
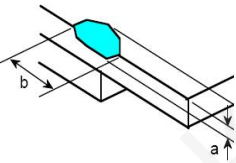
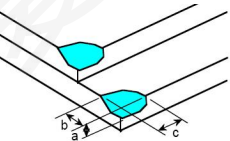
No.	Item 项目	Criteria (Unit: mm) 标准															
01	Black / White spot Foreign material (Round type) Pinholes Stain Particles inside cell. (Minor defect) 黑/白斑/异物 (圆类型)细胞内的针孔染色颗粒。(小瑕疵)	 <table border="1" data-bbox="954 219 1433 618"> <thead> <tr> <th>Size \ Area</th> <th>Acc. Qty</th> </tr> </thead> <tbody> <tr> <td>$\phi \leq 0.10$</td> <td>Ignore</td> </tr> <tr> <td>$0.10 < \phi \leq 0.2$</td> <td>2</td> </tr> <tr> <td>$0.2 < \phi$</td> <td>0</td> </tr> <tr> <td>Total</td> <td>$N \leq 3$ NO include $\phi \leq 0.10$</td> </tr> </tbody> </table> <p>$\phi = (a + b) / 2$</p> <p>Distance between 2 defects should more than 10mm apart.</p>	Size \ Area	Acc. Qty	$\phi \leq 0.10$	Ignore	$0.10 < \phi \leq 0.2$	2	$0.2 < \phi$	0	Total	$N \leq 3$ NO include $\phi \leq 0.10$					
Size \ Area	Acc. Qty																
$\phi \leq 0.10$	Ignore																
$0.10 < \phi \leq 0.2$	2																
$0.2 < \phi$	0																
Total	$N \leq 3$ NO include $\phi \leq 0.10$																
02	Black and White line Scratch Foreign material (Line type) (Minor defect) 黑白线刮伤异物(类型)行 (小瑕疵)	 <table border="1" data-bbox="635 958 1257 1249"> <thead> <tr> <th>Length</th> <th>Width</th> <th>Acc. Qty</th> </tr> </thead> <tbody> <tr> <td>/</td> <td>$W \leq 0.03$</td> <td>Ignore</td> </tr> <tr> <td>$L \leq 3$</td> <td>$0.05 < W \leq 0.08$</td> <td>2</td> </tr> <tr> <td>/</td> <td>$0.08 < W$</td> <td>0</td> </tr> <tr> <td colspan="2">Total</td> <td>$N \leq 2$</td> </tr> </tbody> </table> <p>Distance between 2 defects should more than 10mm apart. Scratches not viewable through the back of the display are acceptable.</p>	Length	Width	Acc. Qty	/	$W \leq 0.03$	Ignore	$L \leq 3$	$0.05 < W \leq 0.08$	2	/	$0.08 < W$	0	Total		$N \leq 2$
Length	Width	Acc. Qty															
/	$W \leq 0.03$	Ignore															
$L \leq 3$	$0.05 < W \leq 0.08$	2															
/	$0.08 < W$	0															
Total		$N \leq 2$															
03	Glass Crack (Minor defect) 玻璃裂纹(小瑕疵)	 <p>LCD with extensible crack line is unacceptable(When press the cracked LCD area, the line will expand, we define it is extensible crack line)</p>															
04	Glass Chipping Pad Area: (Minor defect) 玻璃碎片面积:(轻微缺陷)	<table border="1" data-bbox="774 1877 1244 1977"> <thead> <tr> <th>Length and Width</th> <th>Acc. Qty</th> </tr> </thead> <tbody> <tr> <td>$c < 5.0, b < 0.4$</td> <td>Ignore</td> </tr> </tbody> </table>	Length and Width	Acc. Qty	$c < 5.0, b < 0.4$	Ignore											
Length and Width	Acc. Qty																
$c < 5.0, b < 0.4$	Ignore																

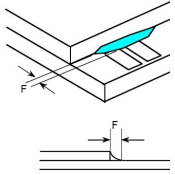
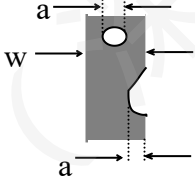
No.	Item 项目	Criteria (Unit: mm) 标准										
												
05	<p>Glass Chipping Rear of Pad Area: (Minor defect) 玻璃切屑垫区后方: (小瑕疵)</p> 	<table border="1"> <thead> <tr> <th>Length and Width</th> <th>Acc. Qty</th> </tr> </thead> <tbody> <tr> <td>$c > 3.0, b < 1.0$</td> <td>1</td> </tr> <tr> <td>$c < 3.0, b < 1.0$</td> <td>2</td> </tr> <tr> <td>$c < 3.0, b < 0.5$</td> <td>4</td> </tr> <tr> <td colspan="2" style="text-align: center;">$a < \text{Glass Thickness}$</td> </tr> </tbody> </table>	Length and Width	Acc. Qty	$c > 3.0, b < 1.0$	1	$c < 3.0, b < 1.0$	2	$c < 3.0, b < 0.5$	4	$a < \text{Glass Thickness}$	
Length and Width	Acc. Qty											
$c > 3.0, b < 1.0$	1											
$c < 3.0, b < 1.0$	2											
$c < 3.0, b < 0.5$	4											
$a < \text{Glass Thickness}$												
06	<p>Glass Chipping Except Pad Area: (Minor defect) 除垫区外的玻璃切屑: (小瑕疵)</p> 	<table border="1"> <thead> <tr> <th>Length and Width</th> <th>Acc. Qty</th> </tr> </thead> <tbody> <tr> <td>$c \leq 0.6, b < 5.0$</td> <td>Ignore</td> </tr> <tr> <td colspan="2" style="text-align: center;">$a < \text{Glass Thickness}$</td> </tr> </tbody> </table>	Length and Width	Acc. Qty	$c \leq 0.6, b < 5.0$	Ignore	$a < \text{Glass Thickness}$					
Length and Width	Acc. Qty											
$c \leq 0.6, b < 5.0$	Ignore											
$a < \text{Glass Thickness}$												
07	<p>Glass Corner Chipping: (Minor defect) 玻璃切角: (小瑕疵)</p> 	<table border="1"> <thead> <tr> <th>Length and Width</th> <th>Acc. Qty</th> </tr> </thead> <tbody> <tr> <td>$c < 2.0, b < 1.5$</td> <td>Ignore</td> </tr> <tr> <td>$c < 1.5, b < 2$</td> <td>Ignore</td> </tr> <tr> <td colspan="2" style="text-align: center;">$a < \text{Glass Thickness}$</td> </tr> </tbody> </table>	Length and Width	Acc. Qty	$c < 2.0, b < 1.5$	Ignore	$c < 1.5, b < 2$	Ignore	$a < \text{Glass Thickness}$			
Length and Width	Acc. Qty											
$c < 2.0, b < 1.5$	Ignore											
$c < 1.5, b < 2$	Ignore											
$a < \text{Glass Thickness}$												

No.	Item 项目	Criteria (Unit: mm) 标准										
08	Glass Burr: (Minor defect) 玻璃磨:(小瑕疵) 	Glass burr don't affect assemble and module dimension. <table border="1" data-bbox="775 311 1246 412"> <thead> <tr> <th>Length</th> <th>Acc. Qty</th> </tr> </thead> <tbody> <tr> <td>$F < 0.5$</td> <td>Ignore</td> </tr> </tbody> </table>	Length	Acc. Qty	$F < 0.5$	Ignore						
Length	Acc. Qty											
$F < 0.5$	Ignore											
09	FPC Defect: (Minor defect) FPC 缺陷:(小瑕疵) 	9.1 Dent, pinhole width $a < w/3$. (w: circuitry width.) 9.2 Open circuit is unacceptable. 9.3 No oxidation, contamination and distortion.										
10	Screen deformation 屏幕上的变形 	Test for insertion of plug gauge at highest warping point: (3.1-6.0inches) $H \cong 0.3MM$ The client has special requirements,according to drawing										
11	Bubble on Polarizer (Minor defect) 偏光片上的气泡(小瑕疵)	<table border="1" data-bbox="775 1252 1246 1509"> <thead> <tr> <th>Diameter</th> <th>Acc. Qty</th> </tr> </thead> <tbody> <tr> <td>$\varphi \leq 0.15$</td> <td>Ignore</td> </tr> <tr> <td>$0.15 < \varphi \leq 0.25$</td> <td>2</td> </tr> <tr> <td>$0.25 < \varphi \leq 0.3$</td> <td>1</td> </tr> <tr> <td>$0.3 < \varphi$</td> <td>0</td> </tr> </tbody> </table>	Diameter	Acc. Qty	$\varphi \leq 0.15$	Ignore	$0.15 < \varphi \leq 0.25$	2	$0.25 < \varphi \leq 0.3$	1	$0.3 < \varphi$	0
Diameter	Acc. Qty											
$\varphi \leq 0.15$	Ignore											
$0.15 < \varphi \leq 0.25$	2											
$0.25 < \varphi \leq 0.3$	1											
$0.3 < \varphi$	0											
12	Dent on Polarizer (Minor defect) 偏光片上的凹痕(小瑕疵)	<table border="1" data-bbox="775 1525 1246 1778"> <thead> <tr> <th>Diameter</th> <th>Acc. Qty</th> </tr> </thead> <tbody> <tr> <td>$\varphi \leq 0.15$</td> <td>Ignore</td> </tr> <tr> <td>$0.15 < \varphi \leq 0.25$</td> <td>2</td> </tr> <tr> <td>$0.25 < \varphi \leq 0.30$</td> <td>1</td> </tr> <tr> <td>$0.3 < \varphi$</td> <td>0</td> </tr> </tbody> </table>	Diameter	Acc. Qty	$\varphi \leq 0.15$	Ignore	$0.15 < \varphi \leq 0.25$	2	$0.25 < \varphi \leq 0.30$	1	$0.3 < \varphi$	0
Diameter	Acc. Qty											
$\varphi \leq 0.15$	Ignore											
$0.15 < \varphi \leq 0.25$	2											
$0.25 < \varphi \leq 0.30$	1											
$0.3 < \varphi$	0											
13	Bezel 边框	13.1 No rust, distortion on the Bezel.										

No.	Item 项目	Criteria (Unit: mm) 标准
14	Touch Panel 触控面板	D: Diameter W: width L: length 14.1 Spot: $D \leq 0.20$ is acceptable $0.20 < D \leq 0.3$, acceptable QTY, 3 $D > 0.3$ is unacceptable 14.2 Dent (dot): $D \leq 0.20$ is acceptable $0.20 < D \leq 0.3$, acceptable QTY, 3 $D > 0.30$ is unacceptable 2dots are acceptable and the distance between defects should more than 10 mm. Dent (line) According to the limit sample 14.3 Scratch: $W \leq 0.03$, $L \leq 10$ is acceptable, $0.03 < W \leq 0.10$, $L \leq 10$,acceptable QTY, 3 $W > 0.10$ is unacceptable. Distance between 2 defects should more than 10 mm.
15	PCB	15.1 No distortion or contamination on PCB terminals. 15.2 All components on PCB must same as documented on the BOM/component layout. 15.3 Follow IPC-A-600F.
16	Soldering 焊接	Follow IPC-A-610C standard
17	Electrical Defect (Major defect) 电气缺陷(主要缺陷)	The below defects must be rejected. 17.1 Missing vertical / horizontal segment, 17.2 Abnormal Display. 17.3 No function or no display. 17.4 Current exceeds product specifications. 17.5 LCD viewing angle defect. 17.6 No Backlight. 17.7 Dark Backlight. 17.8 Touch Panel no function. 17.9 Dark Dot –one Allowed. 17.10 Bright Dot – one Allowed. Remark: 1. A pixel defect is acceptable if one color is none functional and causes a bright dot. The display may have one case where one color is out and cause a dark dot. 2. Bright dot caused by scratch and foreign object accords to item1.
18	Light leak 漏光	Yellow light OK; White light,According to the limit sample

Remark: Visual and cosmetic defects are rejectable only if these fall within the LCD viewing area.

10.5 Classification of Defects 缺陷的分类

Visual defects (Except no / wrong label) are treated as minor defect and electrical defect is major.

10.6 Identification/marketing criteria 识别/评分标准

Any unit with illegible / wrong /double or no marking/ label shall be rejected.

10.7 Packing 包装

10.7.1 There should be no damage of the outside carton box, each packaging box should has label in the correct location per packing drawing requirement.

10.7.2 All direct package materials shall offer ESD protection.

11 Reliability Specification 可靠性规范

Item 项目	Condition 条件	Cycle Time 周期时间	Quantity 数量	Remark 备注
Constant Temp. and Constant Humidity Operation Test 恒温恒湿运行试验	+40 ± 3°C, 90 ± 3%RH	96hrs	--	
High Temp. Operation Test 高温操作试验	+70 ± 3°C	96hrs	--	*1
Low Temp. Operation Test 低温操作试验	-20 ± 3°C	96hrs	--	
Thermal Shock Test 热冲击试验	-20 ± 3°C (30min) +70 ± 3°C (30min)	10cycles	--	
ESD Test(end product) ESD 测试 (最终产品)	150pF, 330Ω, ±2KV, Contact	10times	--	*2, *3
	150pF, 330Ω, ±6KV, Air			
Vibration Test(for packaging) 振动测试(包装)	Frequency: 10Hz to 55Hz to 10Hz, Swing: 1.5mm, time: X, Y, Z each 2H.	6hrs	One inner carton	*4

Note 1. For humidity test, DI water should be used.

Inspection Standard: Inspect after 1-2hrs storage at room temperature, the sample shall be free from the following defects:

- Air bubble in the LCD
- Seal Leakage
- Non-display
- Missing Segment
- Glass Crack
- IDD is greater than twice initial value.
- Others as per QA Inspection Criteria

Note 2. No defect is allowed after testing

The End Product ESD value is only indicative and depends on customer ESD protection design for the whole system.

Note 3. ESD should be applied to LCD glass panel, not other areas (such as on IC and so on)

IDD should be within twice initial value.

In case of malfunction defect caused by ESD damage, if it would be recovered to normal state after resetting, it would be judged as a good part.

Note 4. Only upon request.

12 Precautions and Warranty 注意事项和保证

12.1 Safety 安全

12.1.1 The liquid crystal in the LCD is poisonous. Do not put it in your mouth. If the liquid crystal touches your skin or clothes, wash it off immediately using soap and water.

12.1.2 Since the liquid crystal cells are made of glass, do not apply strong impact on them.

Handle with care.

12.2 Handling 处理

12.2.1 Reverse and use within ratings in order to keep performance and prevent damage.

12.2.2 Do not wipe the polarizer with dry cloth, as it might cause scratch. If the surface of the LCD needs to be cleaned, wipe it swiftly with cotton or other soft cloth soaked with petroleum IPA, do not use other chemicals.

12.3 Operation 操作

12.3.1 Do not drive LCD with DC voltage

12.3.2 Response time will increase below lower temperature

12.3.3 Display may change color with different temperature

12.3.4 Mechanical disturbance during operation, such as pressing on the display area, may cause the segments to appear “fractured”.

12.4 Static Electricity 静电

12.4.1 CMOS LSIs are equipped in this unit, so care must be taken to avoid the electro-static charge, by ground human body, etc.

12.4.2 The normal static prevention measures should be observed for work clothes and benches.

12.4.3 The module should be kept into anti-static bags or other containers resistant to static for storage.

12.5 Limited Warranty 有限质量保证

12.5.1 Unless otherwise agreed between HuaXia RGB Display and customer, HuaXia RGB Display will replace or repair any of its LCD and LCM which HuaXia RGB Display found to be defective electrically and visually when inspected in accordance with HuaXia RGB Display Quality Standards, for a period of one year from date of shipment.

12.5.2 The warranty liability of HuaXia RGB Display is limited to repair and/or replacement. HuaXia RGB Display will not be responsible for any consequential loss.

12.5.3 If possible, we suggest you use up all modules in six months. If the module storage time over twelve months, we suggest that recheck it before the module be used.

13 Packaging 包装

TBD

14 Prior Consult Matter 免责声明

1. For HuaXia RGB Display standard products, we keep the right to change material, process for improving the product property without prior notice to our customer.

2. For OEM products, if any changes are needed which may affect the product property, we will consult with our customer in advance.

3. If you have special requirement about reliability condition, please let us know before you start the test on our samples.

Reference 参考

Item 项目	Description 描述	Revision 修订
GC9107	IC Data sheet	V1.0
Panel 1.02 寸 128X115	LCM assembly drawing	V0