

Document Title	DWM133CAF2.0	Product Specification	Page No.	1/28	
Document No.		Issue date	2022/07/27	Revision	00

Product Specification

Product Name: DWM133CAF2.0

Document Issue Date: 2022/07/27

Proposed By			Customer Approval
Designed	Checked	Approved	

- Note :
1. Please contact DWO Company before designing your product based on this product.
 2. The information contained herein is presented merely to indicate the characteristics and performance of our products. No responsibility is assumed by DWO for any intellectual property claims or other problems that may result from application based on the module described herein.



Document Title	DWM133CAF2.0 Product Specification	Page No.	2/28
Document No.		Issue date	2022/07/27
		Revision	00

CONTENTS

1.0	GENERAL DESCRIPTIONS	4
2.0	ABSOLUTE MAXIMUM RATINGS	5
3.0	OPTICAL CHARACTERISTICS	6
4.0	ELECTRICAL CHARACTERISTICS	10
5.0	MECHANICAL CHARACTERISTICS	18
6.0	RELIABILITY CONDITIONS	20
7.0	PACKAGE SPECIFICATION	22
8.0	LOT MARK.....	23
9.0	GENERAL PRECAUTION.....	24
10.0	EDID TABLE FORMAT	26

Document Title	DWM133CAF2.0 Product Specification		Page No.	3/28	
Document No.		Issue date	2022/07/27	Revision	00

1.0 General Descriptions

1.1 Introduction

The DWM133CAF2.0 is a Color Active Matrix Liquid Crystal Display with a back light system. The matrix uses a-Si Thin Film Transistor as a switching device. This TFT LCD has a 13.3 inch diagonally measured active display area with FHD resolution (1,920 horizontal by 1,080 vertical pixels array).

1.2 Features

- Supported FHD Resolution
- eDP Interface
- Wide View Angle
- Compatible with RoHS Standard

1.3 Product Summary

Items	Specifications	Unit	
Screen Diagonal	13.3	inch	
Active Area (H x V)	293.76x165.24	mm	
Number of Pixels (H x V)	1,920 x 1,080	-	
Pixel Pitch (H x V)	0.1530 x 0.1530	mm	
Pixel Arrangement	R.G.B. Vertical Stripe	-	
Display Mode	Normally Black	-	
White Luminance	300 (Typ.)	cd /m ²	
Contrast Ratio	1200 (Typ.)	-	
Response Time	30(Typ.)	ms	
Input Voltage	3.3(Typ.)	V	
Power Consumption	4.5(Max.) @Mosaic Pattern	W	
Weight	230(Max.)	g	
Outline Dimension (H x V x D)	PCB side	300.26(Typ.) x 187.75(Typ.) x 2.50 (Max.)	mm
	LCD side	300.26(Typ.) x 187.75(Typ.) x 2.65(Max.)	mm
Electrical Interface (Logic)	eDP	-	
Support Color	6bit	-	
NTSC	72(Typ.)	%	
Viewing Direction	All	-	
Surface Treatment	AG	-	

Document Title	DWM133CAF2.0 Product Specification	Page No.	4/28
Document No.		Issue date	2022/07/27
		Revision	00

1.4 Functional Block Diagram

Figure 1 shows the functional block diagram of the LCD module.

Figure 1 Block Diagram

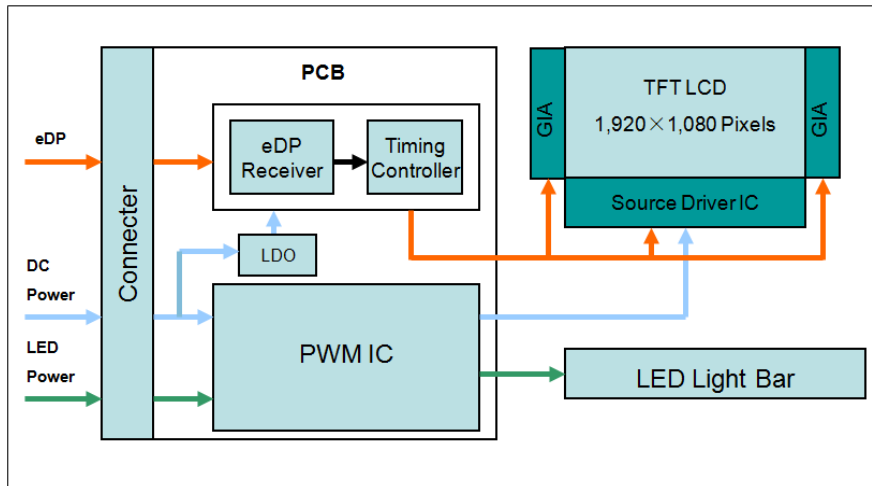

1.5 Pixel Mapping

Figure2 Pixel Mapping

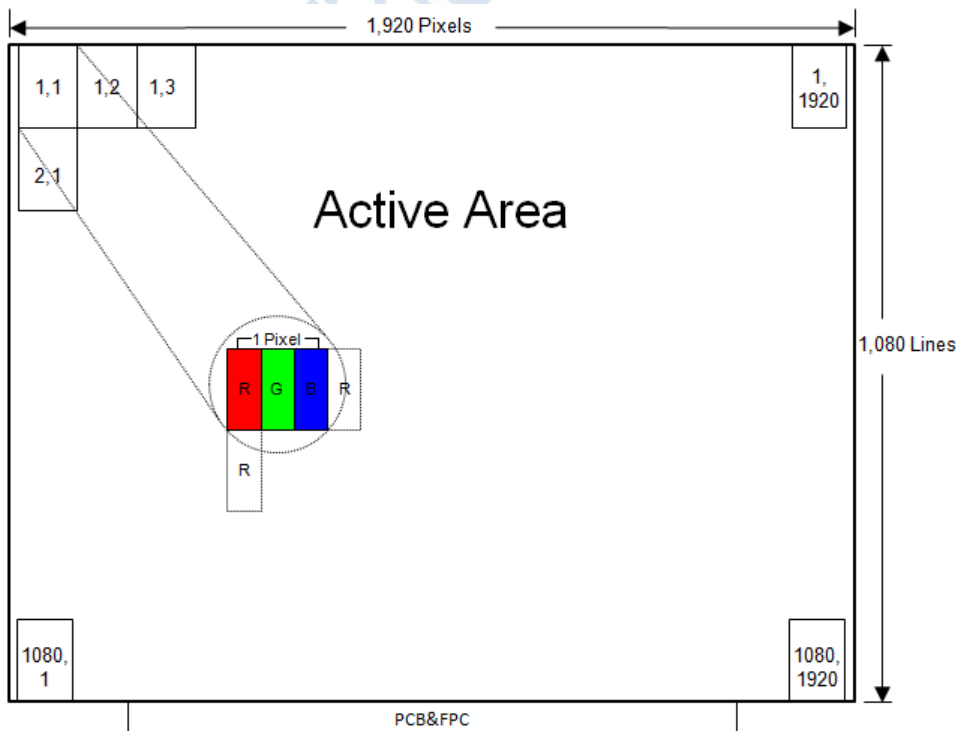

Document Title	DWM133CAF2.0 Product Specification			Page No.	5/28
Document No.		Issue date	2022/07/27	Revision	00

2.0 Absolute Maximum Ratings

Table 1 Electrical & Environment Absolute Rating

Item	Symbol	Min.	Max.	Unit	Note
Logic Supply Voltage	V_{DD}	-0.3	3.6	V	(1),(2),(3),(4)
Logic Input Signal Voltage	V_{Signal}	0.2	0.4	V	
Operating Temperature	T_{gs}	0	50	°C	
Storage Temperature	T_a	-20	60	°C	

Note (1) All the parameters specified in the table are absolute maximum rating values that may cause faulty operation or unrecoverable damage, if exceeded. It is recommended to follow the typical value.

Note (2) All the contents of electro-optical specifications and display fineness are guaranteed under Normal Conditions. All the display fineness should be inspected under normal conditions. Normal conditions are defined as follow: Temperature: 25°C, Humidity: 55± 10%RH.

Note (3) Unpredictable results may occur when it was used in extreme conditions. T_a = Ambient Temperature, T_{gs} = Glass Surface Temperature. All the display fineness should be inspected under normal conditions.

Note (4) Temperature and relative humidity range are shown in the figure below. Wet bulb temperature should be lower than 46°C, and no condensation of water. Besides, protect the module from static electricity.

Figure 3 Absolute Ratings of Environment of the LCD Module

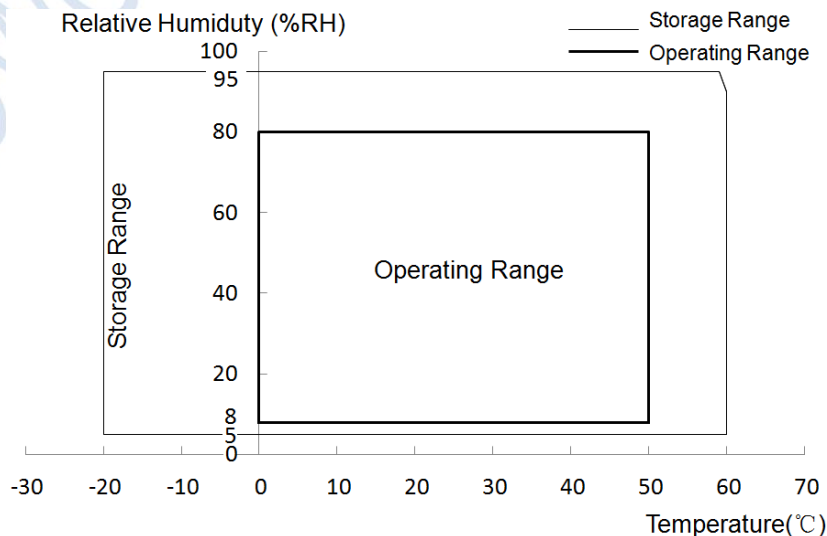

Document Title	DWM133CAF2.0 Product Specification			Page No.	6/28
Document No.		Issue date	2022/07/27	Revision	00

3.0 Optical Characteristics

The optical characteristics are measured under stable conditions as following notes.

Table 2 Optical Characteristics

Item	Conditions	Min.	Typ.	Max.	Unit	Note
Viewing Angle (CR≥10)	Horizontal	θ_{x+}	75	85	-	degree (1),(2),(3),(4),(8)
		θ_{x-}	75	85	-	
	Vertical	θ_{y+}	75	85	-	
		θ_{y-}	75	85	-	
Contrast Ratio	Center	1000	1200	-		(1),(2),(4),(8) $\theta_x=\theta_y=0^\circ$
Response Time	Rising + Falling	-	30	35	ms	(1),(2),(5),(8) $\theta_x=\theta_y=0^\circ$
Color Chromaticity (CIE1931)	Red x	Typ. -0.03	0.640	Typ. +0.03	-	(1),(2),(3),(8) $\theta_x=\theta_y=0^\circ$
	Red y		0.330		-	
	Green x		0.300		-	
	Green y		0.600		-	
	Blue x		0.150		-	
	Blue y		0.060		-	
	White x		0.313		-	
	White y		0.329		-	
NTSC	-	-	72	-	%	(1),(2),(3),(8) $\theta_x=\theta_y=0^\circ$
White Luminance	5 Points Average	250	300	-	cd/m ²	(1),(2),(6),(8) $\theta_x=\theta_y=0^\circ$
Luminance Uniformity	5 Points	80	-	-	%	(1),(2),(7),(8) $\theta_x=\theta_y=0^\circ$
	13 Points	60	-	-		

Note (1) Measurement Setup:

The LCD module should be stabilized at given ambient temperature (25°C) for 30 minutes to avoid abrupt temperature changing during measuring. In order to stabilize the luminance, the measurement should be executed after lighting backlight for 30 minutes in the windless room.

Document Title	DWM133CAF2.0 Product Specification	Page No.	7/28
Document No.	Issue date	2022/07/27	Revision 00

Figure 4 Measurement Setup

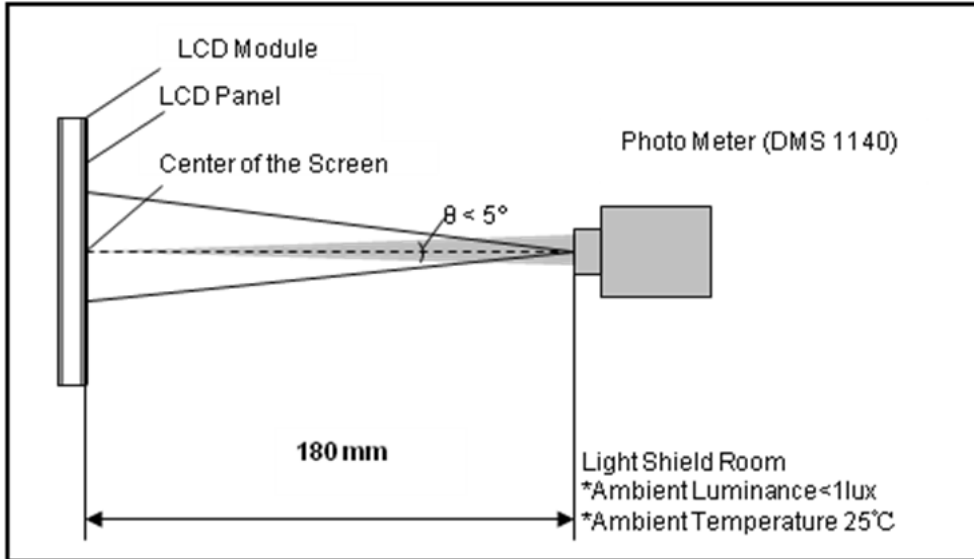

Note (2) The LED input parameter setting as:

$$V_{\text{LED}} = 12\text{V}$$

PWM_LED: Duty 100%

Note (3) Definition of Viewing Angle

Figure 5 Definition of Viewing Angle

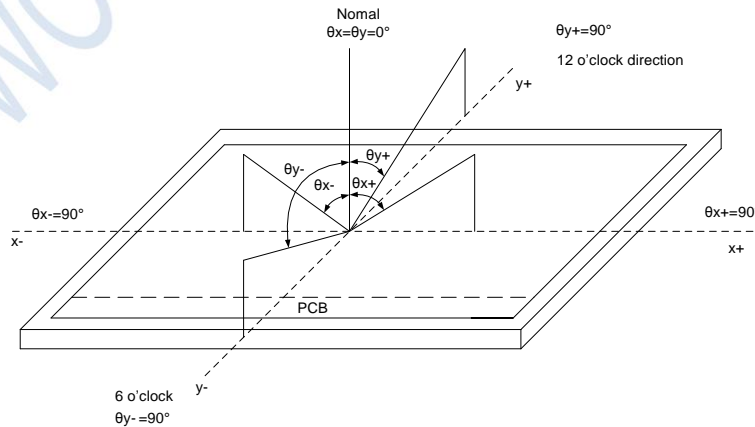

Document Title	DWM133CAF2.0 Product Specification	Page No.	8/28
Document No.	Issue date	2022/07/27	Revision
			00

Note (4) Definition of Contrast Ratio (CR)

The contrast ratio can be calculated by the following expression:

$$\text{Contrast Ratio (CR)} = L_{255} / L_0$$

L255: Luminance of gray level 255, L0: Luminance of gray level 0

Note (5) Definition of Response Time (T_R , T_F)

Figure 6 Definition of Response Time

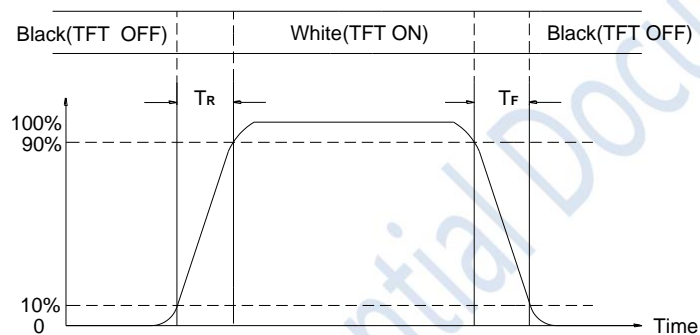

Note (6) Definition of Luminance White

Measure the luminance of gray level 255 (Ref.: Active Area)

$$\text{Display Luminance} = (L_1 + L_2 + L_3 + L_4 + L_5) / 5$$

H—Active Area Width, V—Active Area Height, L—Luminance

Figure 7 Measurement Locations of 5 Points

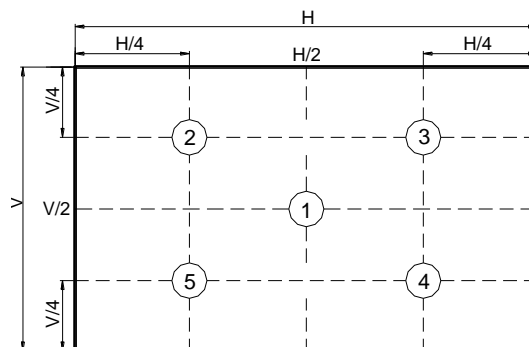

Note (7) Definition of Luminance Uniformity (Ref.: Active Area)

Measure the luminance of gray level 255 at 5 points.

$$\text{Luminance Uniformity} = \text{Min.}(L_1, L_2, \dots, L_5) / \text{Max.}(L_1, L_2, \dots, L_5)$$

Document Title	DWM133CAF2.0 Product Specification	Page No.	9/28
Document No.		Issue date	2022/07/27
		Revision	00

Measure the luminance of gray level 255 at 13 points.

$$\text{Luminance Uniformity} = \text{Min.}(L1, L2, \dots L13) / \text{Max.}(L1, L2, \dots L13)$$

H—Active Area Width, V—Active Area Height, L—Luminance

Figure 8 Measurement Locations of 13 Points

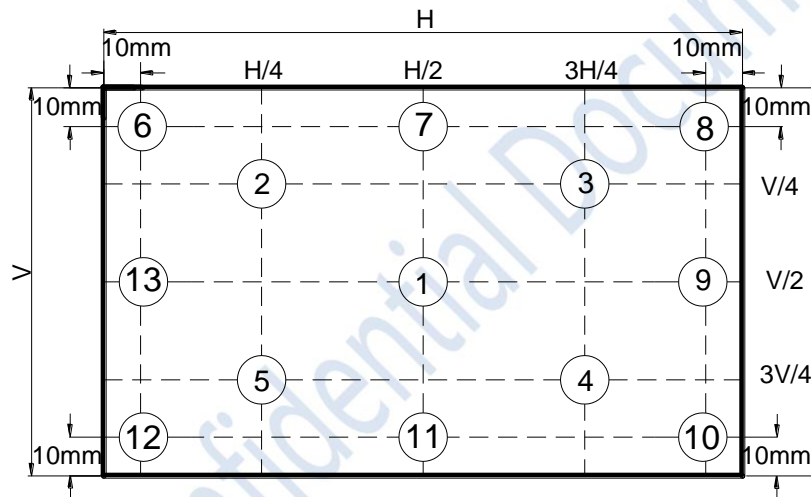

Note (8) All optical data based on DW given system & nominal parameter & testing machine in this document.

Document Title	DWM133CAF2.0 Product Specification			Page No.	10/28
Document No.		Issue date	2022/07/27	Revision	00

4.0 Electrical Characteristics

4.1 Interface Connector

Table 3 Signal Connector Type

Item	Description
Manufacturer / Type	IPEX 20455-030E

Table 4 Signal Connector Pin Assignment

Pin No.	Symbol	Description	Remarks
1	NC Reserved	Reserved for LCD manufacturer's use	-
2	GND	High Speed Ground	-
3	Lane1_N	Complement Signal Link Lane 1	-
4	Lane1_P	True Signal Link Lane 1	-
5	GND	High Speed Ground	-
6	Lane0_N	Complement Signal Link Lane 0	-
7	Lane0_P	True Signal Link Lane 0	-
8	GND	High Speed Ground	-
9	AUX_CH_P	True Signal Auxiliary Channel	-
10	AUX_CH_N	Complement Signal Auxiliary Channel	-
11	GND	High Speed Ground	-
12	VDD	LCD logic and driver power	-
13	VDD	LCD logic and driver power	-
14	NC	LCD Panel Self Test Enable	-
15	GND	LCD logic and driver ground	-
16	GND	LCD logic and driver ground	-
17	HPD	HPD signal pin	-
18	BL_GND	LED Backlight ground	-
19	BL_GND	LED Backlight ground	-
20	BL_GND	LED Backlight ground	-
21	BL_GND	LED Backlight ground	-
22	BL_ENABLE	LED Backlight control on/off control	-
23	BL_PWM	System PWM signal input for dimming	-
24	Hsync	Hsync for Pen Touch	-
25	NC Reserved	Reserved for LCD manufacturer's use	-
26	VLED	LED Backlight power (12V Typical)	-
27	VLED	LED Backlight power (12V Typical)	-
28	VLED	LED Backlight power (12V Typical)	-

Document Title	DWM133CAF2.0 Product Specification		Page No.	11/28	
Document No.		Issue date	2022/07/27	Revision	00

29	VLED	LED Backlight power (12V Typical)	-
30	NC Reserved	Reserved for LCD manufacturer's use	-

4.2 Signal Electrical Characteristics

Table 5 Display Port Main Link

Parameter	Description	Min.	Typ.	Max.	Unit
V_{CM}	Differentia Common Mode Voltage	0	-	2.0	V
$V_{DIFF P-P}$ Level 1	Differential Peak to Peak Voltage Level 1	0.34	0.40	0.46	V
$V_{DIFF P-P}$ Level 2	Differential Peak to Peak Voltage Level 2	0.51	0.60	0.68	V
$V_{DIFF P-P}$ Level 3	Differential Peak to Peak Voltage Level 3	0.69	0.80	0.92	V
$V_{DIFF P-P}$ Level 4	Differential Peak to Peak Voltage Level 4	1.02	1.20	1.38	V

Note: (1) Input signals shall be low or Hi- resistance state when VDD is off.

(2) It is recommended to refer the specifications of VESA Display Port Standard V1.2 in detail.

(3) Follow as VESA display port standard V1.2 at both 1.62 and 2.7Gbps link rates.

Figure 9 Display Port Main Link Signal

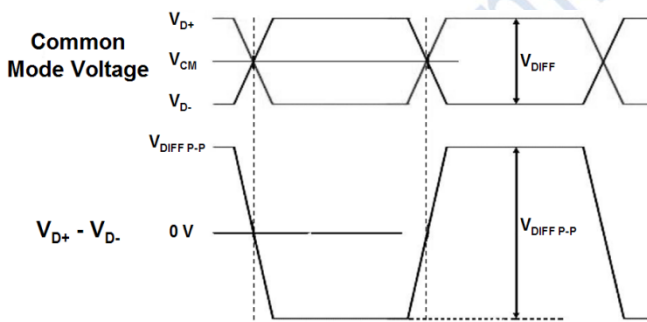

Figure 10 Display Port AUX_CH Signal

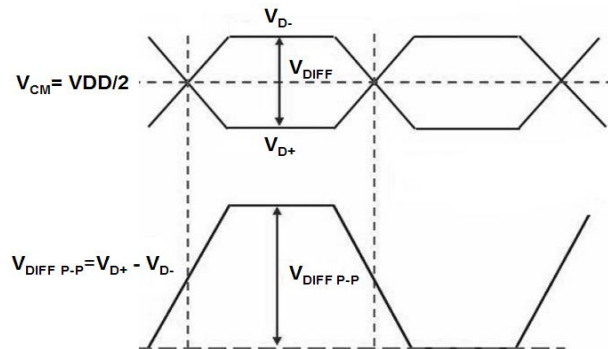

Table 6 Display Port AUX_CH

Parameter	Description	Min.	Typ.	Max.	Unit
V_{CM}	Differentia Common Mode Voltage	0	$V_{DD}/2$	2	V
$V_{DIFF P-P}$	Differential Peak to Peak Voltage	0.39	-	1.38	V

Note: Follow as VESA display port standard V1.2.

Document Title	DWM133CAF2.0 Product Specification			Page No.	12/28
Document No.		Issue date	2022/07/27	Revision	00

Table 7 Display Port V_{HPD}

Parameter	Description	Min.	Typ.	Max.	Unit
V _{HPD}	HPD Voltage	2.25	-	3.60	V

Note: Follow as VESA display port standard V1.2.

4.3 Interface Timings

Table 8 Interface Timings

Parameter	Symbol	Min.	Typ.	Max.	Unit
Clock Frequency	Fclk	87.9	138.5	145.4	MHz
H Total Time	HT	2040	2080	2120	Clocks
H Active Time	HA	1,920			Clocks
V Total Time	VT	1104	1112	1120	Lines
V Active Time	VA	1,080			Lines
Frame Rate	FV	48	60	65	Hz

Note (1): $HT \cdot VT \cdot FV < 145.4 \text{MHz}$

Note (2): All reliabilities are specified for timing specification based on refresh rate of 60Hz.

However, RM133NWF4 R0 has a good actual performance even at lower refresh rate (e.g. 48Hz) for power saving mode, whereas RM133NWF4 R0 is secured only for function under lower refresh rate; 60Hz at Normal mode, 48Hz at Power save mode.

Document Title	DWM133CAF2.0 Product Specification			Page No.	13/28
Document No.		Issue date	2022/07/27	Revision	00

4.4 Input Power Specifications

Input power specifications are as follows.

Table 9 Input Power Specifications

Parameter	Symbol	Min.	Typ.	Max.	Unit	Note	
<i>System Power Supply</i>							
LCD Drive Voltage (Logic)	V_{DD}	3	3.3	3.6	V	(1),(2),(3)	
VDD Current	Mosaic Pattern	I_{DD}	-	-	0.47	A	(1),(4)
VDD Power Consumption	Mosaic Pattern	P_{DD}	-	-	1.6	W	
Rush Current		I_{Rush}	-	-	1.5	A	(1),(5)
Allowable Logic/LCD Drive Ripple Voltage		V_{VDD-RP}	-	-	200	mV	(1)
<i>LED Power Supply</i>							
LED Input Voltage	V_{LED}	5	12	21	V	(1),(2)	
LED Power Consumption	P_{LED}	-	-	2.97	W	(1),(6)	
LED Forward Voltage	V_F	2.8	3.0	3.3	V	(1),(2)	
LED Forward Current	I_F	-	20	-	mA		
PWM Signal Voltage	High	V_{PWM}	2	3.3	3.6		V
	Low		-	0	0.8		
LED Enable Voltage	High	V_{LED_EN}	2	3.3	3.6	V	
	Low		-	0	0.8		
Input PWM Frequency	F_{PWM}	100	200	1000	Hz	(1),(2),(7)	
Duty Ratio	PWM	1	-	100	%	(1),(8)	
LED Life Time	LT	15,000	-	-	Hours	(1),(9)	

Note (1) All of the specifications are guaranteed under normal conditions. Normal conditions are defined as follow: Temperature: 25°C, Humidity: 55± 10%RH.

Note (2) All of the absolute maximum ratings specified in the table, if exceeded, may cause faulty operation or unrecoverable damage. It is recommended to follow the typical value.

Note (3) VDD Power Dip Condition for Lenovo.

Document Title	DWM133CAF2.0 Product Specification	Page No.	14/28
Document No.	Issue date	2022/07/27	Revision 00

Figure 11 VDD Power Dip

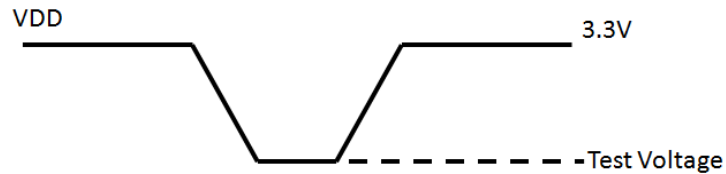

Test criteria:

- 1) $2.4 \leq \text{Test Voltage} \leq 3.3\text{V}$: Normal operation
- 2) $2.0\text{V} \leq \text{Test Voltage} < 2.4\text{V}$: No abnormal display after back to 3.3V input.

Note (4) The specified V_{DD} current and power consumption are measured under the $V_{DD} = 3.3\text{V}$, $F_V = 60\text{Hz}$ condition and Mosaic Pattern.

Figure 12 Mosaic pattern

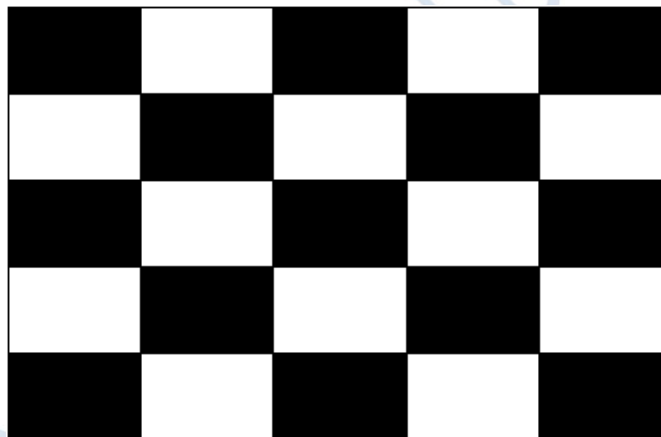

Note (5) The figures below is the measuring condition of V_{DD} . Rush current can be measured when T_{RUSH} is 0.5 ms.

Figure 13 V_{DD} Rising Time

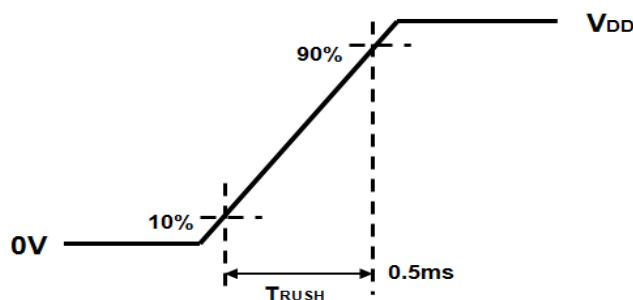

Note (6) The power consumption of LED Driver are under the $V_{LED} = 12.0\text{V}$, Dimming of Max luminance.

Note (7) Although acceptable range as defined, the dimming ratio is not effective at all conditions. The PWM frequency should be fixed and stable for more consistent luminance control at any



Document Title	DWM133CAF2.0	Product Specification	Page No.	15/28	
Document No.		Issue date	2022/07/27	Revision	00

specific level desired.

Note (8) The operation of LED Driver below minimum dimming ratio may cause flickering or reliability issue.

Note (9) The life time is determined as the sum of the lighting time till the luminance of LCD at the typical LED current reducing to 50% of the minimum value under normal operating condition.

DWO Confidential Documents

Document Title	DWM133CAF2.0 Product Specification	Page No.	16/28
Document No.		Issue date	2022/07/27
		Revision	00

4.5 Power ON/OFF Sequence

Interface signals are also shown in the chart. Signals from any system shall be Hi- resistance state or low level when VDD voltage is off.

Figure 14 Power Sequence

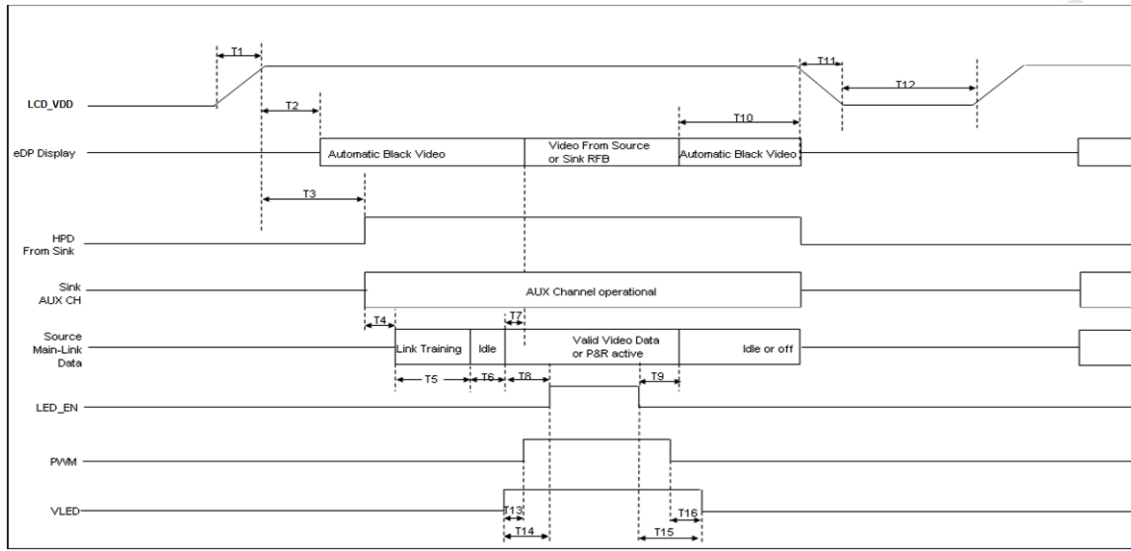

Table 10 Power Sequencing Requirements

Parameter	Symbol	Min.	Typ.	Max.	Unit
VDD Rise Time (10% to 90%)	T1	0.5	-	10	ms
Delay from VDD to automatic Black Video generation	T2	0	-	200	ms
Delay from VDD to HPD high	T3	0	-	200	ms
Delay from HPD high to link training initialization	T4	-	-	-	ms
Link training duration	T5	-	-	-	ms
Link idle	T6	-	-	-	ms
Delay from valid video data from Source to video on display	T7	0	-	50	ms
Delay from valid video data from Source to backlight enable	T8	-	-	-	ms
Delay from backlight disable to end of valid video data	T9	-	-	-	ms
Delay from end of valid video data from Source to VDD off	T10	0	-	500	ms
VDD fall time (90% to 10%)	T11	0	-	10	ms
VDD off time	T12	500	-	-	ms
Delay from VLED to PWM	T13	0	-	-	ms
Delay from VLED to backlight enable	T14	0	-	-	ms
Delay from backlight disable to VLED off	T15	0	-	-	ms
Delay from PWM off to VLED off	T16	0	-	-	ms

Document Title	DWM133CAF2.0 Product Specification		Page No.	17/28	
Document No.		Issue date	2022/07/27	Revision	00

5.0 Mechanical Characteristics

5.1 Outline Drawing

Figure 15 Reference Outline Drawing (Front Side)

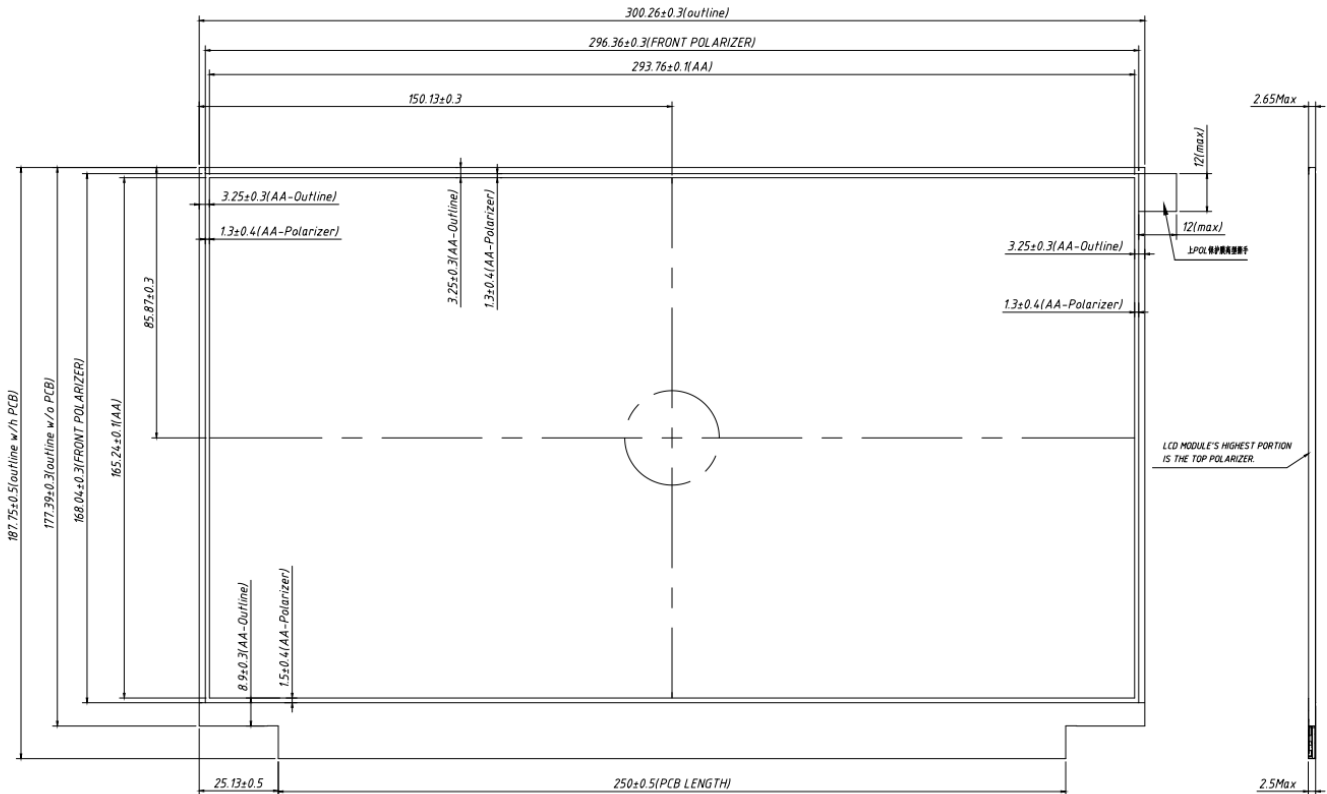

Document Title	DWM133CAF2.0 Product Specification		Page No.	18/28	
Document No.		Issue date	2022/07/27	Revision	00

Figure 16 Reference Outline Drawing (Back Side)

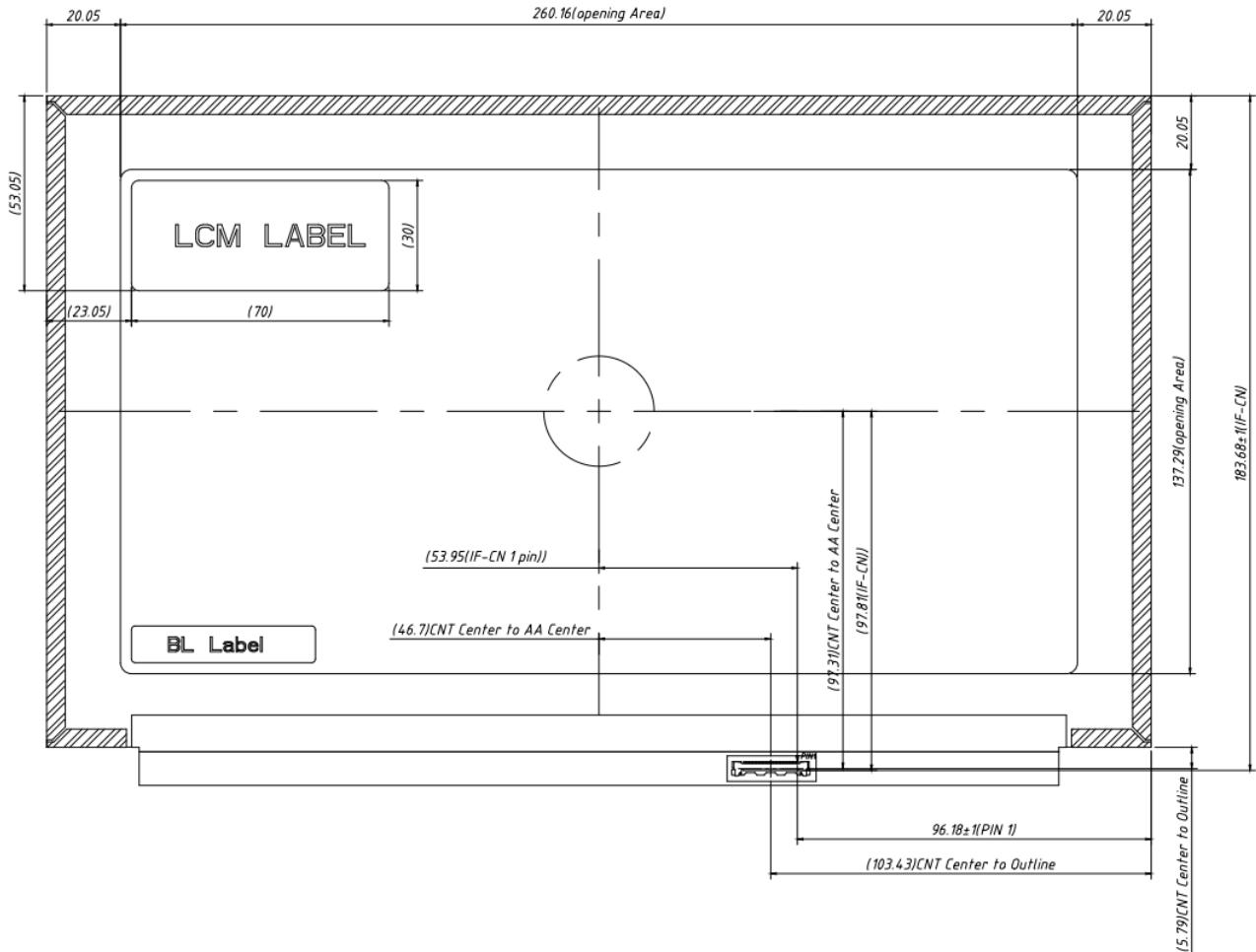

5.2 Dimension Specifications

Table 11 Module Dimension Specifications

Item	Min.	Typ.	Max.	Unit
Width	299.96	300.26	300.56	mm
Height	187.25	187.75	188.25	mm
Thickness	PCB side	-	2.5	mm
	LCD side	-	2.65	mm
Weight	-	-	230	g

Document Title	DWM133CAF2.0 Product Specification		Page No.	19/28	
Document No.		Issue date	2022/07/27	Revision	00

6.0 Reliability Conditions

Table 12 Reliability Condition

Item	Package	Test Conditions	Note
High Temperature/High Humidity Operating Test	Module	$T_{gs}=(50^{\circ}\text{C}, 80\%\text{RH}, 1000 \text{ hours})$	(1),(2),(3), (4)
Low Temperature Operating Test	Module	$T_a=0^{\circ}\text{C}, 500 \text{ hours}$	
High Temperature Storage Test	Module	$T_a=60^{\circ}\text{C}, 240 \text{ hours}$	(1),(3),(4)
Low Temperature Storage Test	Module	$T_a=-20^{\circ}\text{C}, 240 \text{ hours}$	
Shock Non-operating Test	Module	210G, 3ms half-sine $\pm x \pm y \pm z$ each axis/1times 50G, 18msec Trapezoidal $\pm x \pm y \pm z$ each axis/1times	(1),(3),(5)
Vibration Non-operating Test	Module	1.5G , 10~200 Hz , x · y · z each axis/30min.	
ESD Test	Operating	Module	(1),(2),(6)
		Contact	
		Air	$\pm 15\text{KV}, 150\text{pF}(330\text{Ohm})$

Note (1) A sample can only have one test. Outward appearance, image quality and optical data can only be checked at normal conditions according to the DW document before reliable test. Only check the function of the module after reliability test.

Note (2) The setting of electrical parameters should follow the typical value before reliability test.

Note (3) During the test, it is unaccepted to have condensate water remains. Besides, protect the module from static electricity.

Note (4) The sample must be released for 24 hours under normal conditions before judging.

Furthermore, all the judgment must be made under normal conditions. Normal conditions are defined as follow: Temperature: 25°C , Humidity: $55 \pm 10\%\text{RH}$. T_a = Ambient Temperature, T_{gs} = Glass Surface Temperature.

Note (5) The module should be fixed firmly in order to avoid twisting and bending.

Note (6) It could be regarded as pass, when the module recovers from function fault caused by ESD after resetting.

Document Title	DWM133CAF2.0 Product Specification	Page No.	20/28
Document No.		Issue date	2022/07/27
		Revision	00

7.0 Package Specification

Figure 18 Packing Method

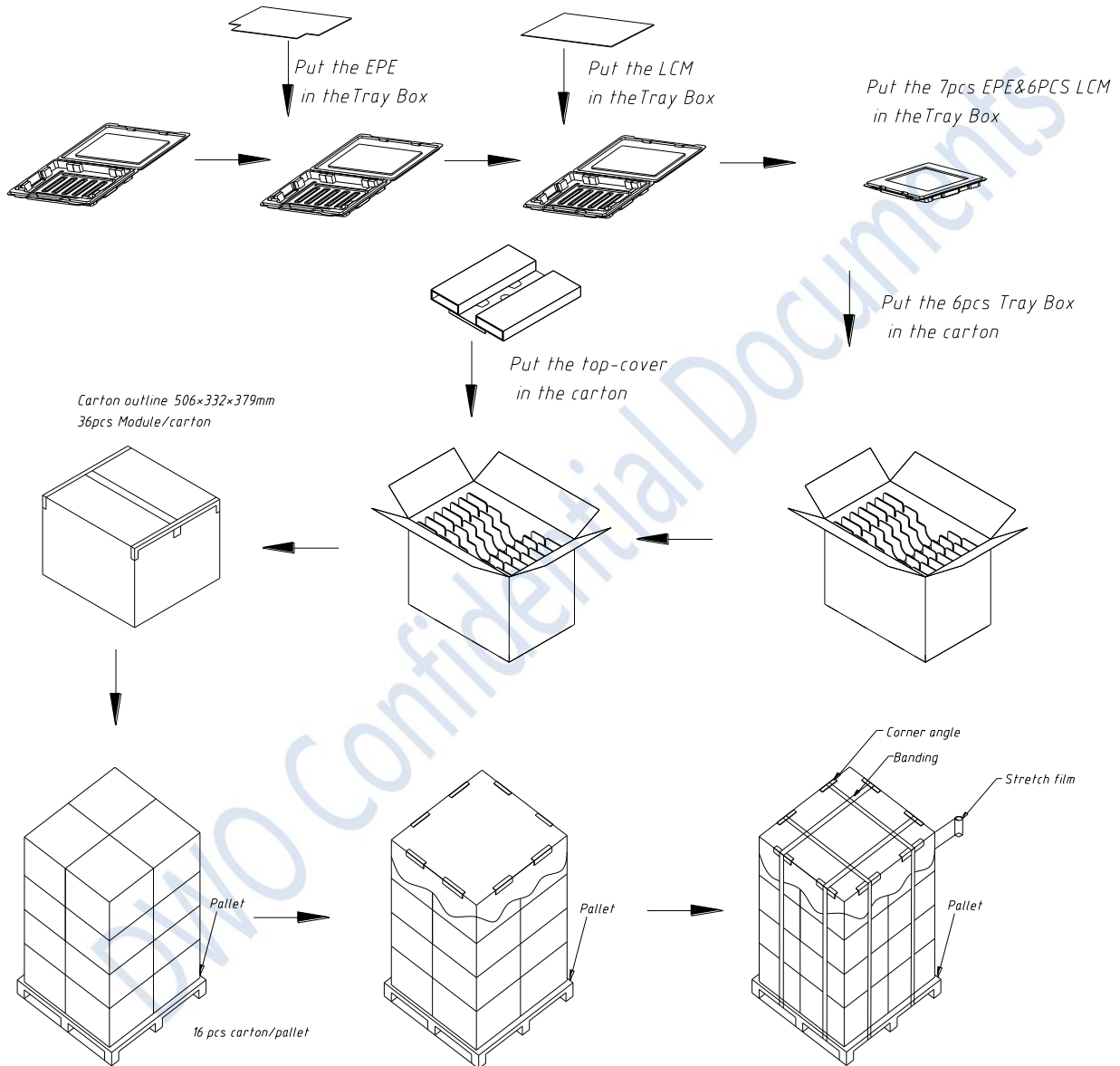

Document Title	DWM133CAF2.0	Product Specification	Page No.	21/28	
Document No.		Issue date	2022/07/27	Revision	00

9.0 General Precaution

9.1 Using Restriction

This product is not authorized for using in life supporting systems, aircraft navigation control systems, military systems and any other appliance where performance failure could be life-threatening or lead to be catastrophic.

9.2 Operation Precaution

(1) The LCD product should be operated under normal conditions.

Normal conditions are defined as below:

Temperature: 25°C

Humidity: 55±10%

Display pattern: continually changing pattern (Not stationary)

(2) Brightness and response time depend on the temperature. (It needs more time to reach normal brightness in low temperature.)

(3) It is necessary for you to pay attention to condensation when the ambient temperature drops suddenly. Condensate water would damage the polarizer and electrical contacted parts of the module. Besides, smear or spot will remain after condensate water evaporating.

(4) If the absolute maximum rating value was exceeded, it may damage the module.

(5) Do not adjust the variable resistor located on the module.

(6) Sufficient suppression to the electromagnetic interference shall be done by system manufacturers. Grounding and shielding may be important to minimize the interference.

(7) Image sticking may occur when the module displayed the same pattern for long time.

(8) Do not connect or disconnect the module in the "power on" condition. Power supply should always be turned on/off by the "power on/off sequence"

(9) Ultra-violet ray filter is necessary for outdoor operation.

9.3 Mounting Precaution

(1) All the operators should be electrically grounded and with Ion-blown equipment turning on when mounting or handling. Dressing finger-stalls out of the gloves is important for keeping the panel clean during the incoming inspection and the process of assembly.

(2) It is unacceptable that the material of cover case contains acetic or chloric. Besides, any other material that could generate corrosive gas or cause circuit break by electro-chemical reaction is not desirable.

(3) The case on which a module is mounted should have sufficient strength so that external force is not transmitted to the module directly.

(4) It is obvious that you should adopt radiation structure to satisfy the temperature specification.

(5) It should be attached to the system tightly by using all holes for mounting, when the module is assembled. Be careful not to apply uneven force to the module, especially to the PCB on the back.

(6) A transparent protective film needs to be attached to the surface of the module.

Document Title	DWM133CAF2.0	Product Specification	Page No.	22/28	
Document No.		Issue date	2022/07/27	Revision	00

(7) Do not press or scratch the polarizer exposed with anything harder than HB pencil lead. In addition, don't touch the pin exposed with bare hands directly.

(8) Clean the polarizer gently with absorbent cotton or soft cloth when it is dirty.

(9) Wipe off saliva or water droplet as soon as possible. Otherwise, it may cause deformation and fading of color.

(10) Desirable cleaners are IPA (Isopropyl Alcohol) or hexane. Do not use Ketone type materials (ex. Acetone), Ethyl alcohol, Toluene, Ethyl acid or Methyl chloride. It might permanent damage to the polarizer due to chemical reaction.

(11) Do not disassemble or modify the module. It may damage sensitive parts in the LCD module, and cause scratches or dust remains. DWO does not warrant the module, if you disassemble or modify the module.

9.4 Handling Precaution

(1) Static electricity will generate between the film and polarizer, when the protection film is peeled off. It should be peeled off slowly and carefully by operators who are electrically grounded and with Ion-blown equipment turning on. Besides, it is recommended to peel off the film from the bonding area.

(2) The protection film is attached to the polarizer with a small amount of glue. When the module with protection film attached is stored for a long time, a little glue may remain after peeling.

(3) If the liquid crystal material leaks from the panel, keep it away from the eyes and mouth. In case of contact with hands, legs or clothes, it must be clean with soap thoroughly.

9.5 Storage Precaution

When storing modules as spares for long time, the following precautions must be executed.

(1) Store them in a dark place. Do not expose to sunlight or fluorescent light. Keep the temperature between 5°C and 35°C at normal humidity.

(2) The polarizer surface should not come in contact with any other object. It is recommended that they be stored in the container in which they were shipped.

(3) It is recommended to use it in a short-time period, after it's unpacked. Otherwise, we would not guarantee the quality.

9.6 Others

When disposing LCD module, obey the local environmental regulations.



Document Title	DWM133CAF2.0 Product Specification			Page No.	23/28
Document No.		Issue date	2022/07/27	Revision	00

10.0 EDID Table Format

EDID Table Format

Address (DEC)	Address (HEX)	Field Name & Comments	Value (HEX)	Value (BIN)	Value (DEC)
0	0	Header	00	00000000	0
1	1	Header	FF	11111111	255
2	2	Header	FF	11111111	255
3	3	Header	FF	11111111	255
4	4	Header	FF	11111111	255
5	5	Header	FF	11111111	255
6	6	Header	FF	11111111	255
7	7	Header	00	00000000	0
8	8	manufacture code	26	00100110	38
9	9	manufacture code	CF	11001111	207
10	A	Product Code	36	00110110	54
11	B	Product Code	05	00000101	5
12	C	LCD module Serial No - ("0" if not used)	00	00000000	0
13	D	LCD module Serial No - ("0" if not used)	00	00000000	0
14	E	LCD module Serial No - ("0" if not used)	00	00000000	0
15	F	LCD module Serial No - ("0" if not used)	00	00000000	0
16	10	Week of manufacture	00	00000000	0
17	11	Year of manufacture	1A	00011010	26
18	12	EDID Structure Ver # = 1	01	00000001	1
19	13	EDID revision # = 3	04	00000100	4
20	14	Video I/P definition = Digital I/P (80h)	A5	10100101	165
21	15	Max H image size = (Rounded to cm)	1D	00011101	29
22	16	Max V image size = (Rounded to cm)	11	00010001	17



Document Title	DWM133CAF2.0 Product Specification		Page No.	24/28	
Document No.		Issue date	2022/07/27	Revision	00

23	17	Display Gamma	78	01111000	120
24	18	Feature support (no DPMS, Active off, RGB, timing BLK 1)	0A	00001010	10
25	19	Red/Green Low bits (RxRy/GxGy)	DE	11011110	222
26	1A	Blue/White Low bits (BxBY/WxWy)	50	01010000	80
27	1B	Red X Rx	A3	10100011	163
28	1C	Red Y Ry	54	01010100	84
29	1D	Green X Gx	4C	01001100	76
30	1E	Green Y Gy	99	10011001	153
31	1F	Blue X Bx	26	00100110	38
32	20	Blue Y By	0F	00001111	15
33	21	White X Wx	50	01010000	80
34	22	White Y Wy	54	01010100	84
35	23	Established timings 1 (00h if not used)	00	00000000	0
36	24	Established timing 2 (00h if not used)	00	00000000	0
37	25	Manufacturer's timings (00h if not used)	00	00000000	0
38	26	Standard timing ID1 (01h if not used)	01	00000001	1
39	27	Standard timing ID1 (01h if not used)	01	00000001	1
40	28	Standard timing ID2 (01h if not used)	01	00000001	1
41	29	Standard timing ID2 (01h if not used)	01	00000001	1
42	2A	Standard timing ID3 (01h if not used)	01	00000001	1
43	2B	Standard timing ID3 (01h if not used)	01	00000001	1
44	2C	Standard timing ID4 (01h if not used)	01	00000001	1



Document Title	DWM133CAF2.0 Product Specification		Page No.	25/28	
Document No.		Issue date	2022/07/27	Revision	00

45	2D	Standard timing ID4 (01h if not used)	01	00000001	1
46	2E	Standard timing ID5 (01h if not used)	01	00000001	1
47	2F	Standard timing ID5 (01h if not used)	01	00000001	1
48	30	Standard timing ID6 (01h if not used)	01	00000001	1
49	31	Standard timing ID6 (01h if not used)	01	00000001	1
50	32	Standard timing ID7 (01h if not used)	01	00000001	1
51	33	Standard timing ID7 (01h if not used)	01	00000001	1
52	34	Standard timing ID8 (01h if not used)	01	00000001	1
53	35	Standard timing ID8 (01h if not used)	01	00000001	1
54	36	Pixel Clock LSB	38	00111000	56
55	37	Pixel Clock HSB	36	00110110	54
56	38	Horizontal Active (lower 8 bits)	80	10000000	128
57	39	Hor blanking (lower 8 bits)	A0	10100000	160
58	3A	Horizontal Active/Horizontal blanking (upper4:4 bits)	70	01110000	112
59	3B	Vertical active(lower 8 bits)	38	00111000	56
60	3C	Vertical blanking(lower 8 bits)	20	00100000	32
61	3D	Vertical Active : Vertical Blanking (upper4:4 bits)	40	01000000	64
62	3E	Horizontal Sync Offset	18	00011000	24
63	3F	Horizontal Sync Pulse Width	30	00110000	48
64	40	Vertical Sync Offset , Sync Width	3C	00111100	60
65	41	Horizontal Vertical Sync Offset/Width upper 2 bits	00	00000000	0
66	42	Horizontal Image Size	26	00100110	38



Document Title	DWM133CAF2.0 Product Specification			Page No.	26/28
Document No.		Issue date	2022/07/27	Revision	00

67	43	Vertical image Size	A5	10100101	165
68	44	Horizontal Image Size / Vertical image size	10	00010000	16
69	45	Horizontal Border = (0 for Notebook LCD)	00	00000000	0
70	46	Vertical Border = (0 for Notebook LCD)	00	00000000	0
71	47	Non-interlaced, Normal, no stereo, Separate sync, H/V pol Negatives,	19	00011001	25
72	48	Timing Descriptor #2	00	00000000	0
73	49		00	00000000	0
74	4A		00	00000000	0
75	4B		00	00000000	0
76	4C		00	00000000	0
77	4D		00	00000000	0
78	4E		00	00000000	0
79	4F		00	00000000	0
80	50		00	00000000	0
81	51		00	00000000	0
82	52		00	00000000	0
83	53		00	00000000	0
84	54		00	00000000	0
85	55		00	00000000	0
86	56		00	00000000	0
87	57		00	00000000	0
88	58		00	00000000	0
89	59		00	00000000	0
90	5A	Detailed timing/monitor descriptor#3	00	00000000	0
91	5B	Flag	00	00000000	0
92	5C	Flag	00	00000000	0



Document Title	DWM133CAF2.0 Product Specification			Page No.	27/28
Document No.		Issue date	2022/07/27	Revision	00

93	5D	Range limits	FE	11111110	254
94	5E	Flag	00	00000000	0
95	5F	Min. Vertical Freq	49	01001001	73
96	60	Max. Vertical Freq	6E	01101110	110
97	61	Min. Horizontal Freq	66	01100110	102
98	62	Max. Horizontal Freq	6F	01101111	111
99	63	Max. Pixel Clock Freq	56	01010110	86
100	64		69	01101001	105
101	65		73	01110011	115
102	66		69	01101001	105
103	67		6F	01101111	111
104	68		6E	01101110	110
105	69	New line character indicates end of ASCII string	0A	00001010	10
106	6A		20	00100000	32
107	6B		20	00100000	32
108	6C	Detailed timing/monitor descriptor #4	00	00000000	0
109	6D		00	00000000	0
110	6E		00	00000000	0
111	6F	FE (hex) defines ASCII string	FE	11111110	254
112	70	Flag	00	00000000	0
113	71	Manufacture P/N	4D	01001101	77
114	72	Manufacture P/N	31	00110001	49
115	73	Manufacture P/N	33	00110011	51
116	74	Manufacture P/N	33	00110011	51
117	75	Manufacture P/N	4E	01001110	78
118	76	Manufacture P/N	57	01010111	87
119	77	Manufacture P/N	46	01000110	70
120	78	Manufacture P/N	34	00110100	52
121	79	Manufacture P/N	20	00100000	32



Document Title	DWM133CAF2.0 Product Specification			Page No.	28/28
Document No.		Issue date	2022/07/27	Revision	00

122	7A	Manufacture P/N	52	01010010	82
123	7B	Manufacture P/N	30	00110000	48
124	7C	New line character indicates end of ASCII string	20	00100000	32
125	7D		0A	00001010	10
126	7E	Extension Flag = 00	00	00000000	0
127	7F	Checksum	48	01001000	72

DWO Confidential Document