

深圳市亿显国际科技有限公司 ShenZhen Yes-Display International Technology CO.,LTD.			10.1 寸液晶显示屏 10.1 Inch LCD Display Screen	
File NO.		REV	A/01	http://www.yes-display.com

SPECIFICATION FOR

Module:YS-T101011C01 V1.0

Designed by	R&D Checked by	Quality Department by	Approved by

Approval by Customer:

OK

NG, Problem survey

Approved By _____

Contents

List	Description	Page No.
	Cover	1
	Revision Record	2
	Contents	3
1	Technical parameters	4
2	Block Dimension	5
3	Outline Dimensions	6
4	Input terminal Pin Assignment Description	7
5	LCD Optical Characteristics	9
6	TFT Electrical Characteristics	12
7	Timing Characteristics	13
8	Inspection Standard	16
9	Reliability Test Conditions and Methods	21
10	Cautions and Handling Precautions	23
11	Packing Method	26

深圳市亿显国际科技有限公司 ShenZhen Yes-Display International Technology CO.,LTD.			10.1 寸液晶显示屏 10.1 Inch LCD Display Screen	
File NO.		REV	A/01	http://www.yes-display.com

1. Technical parameters

1.1 LCM General Information

ITEM	STANDARD VALUES	UNITS
LCD type	10.1TFT	--
Dot arrangement	1920(RGB)×1200	dots
Color filter array	RGB vertical stripe	--
Display mode	IPS/ Transmission / Normally Black	-
Eyes Viewing Direction	85/85/85/85	--
Driver IC	TBD	--
Module size	229.45(W)×149.22(H)×2.83(T)	mm
Active area	216.81(W)×135.50(H)	mm
Interface	LVDS	--
Operating temperature	-20 ~ +70	°C
Storage temperature	-30 ~ +80	°C
Back Light	White LED*36	--

1.2 CTP General Information

CTP type	10.1'	--
Outline Dimension	251.00(W)×165.00(H)X4.98(T)	mm
Touch area	217.00(W)×136.00(H)	mm
Max Number of Fingers	6 point	--
Driver IC	GT9271	--
surface hardness	6H	--
Operating temperature	-20 ~ +70	°C
Storage temperature	-30 ~ +80	°C

2. Block Dimension

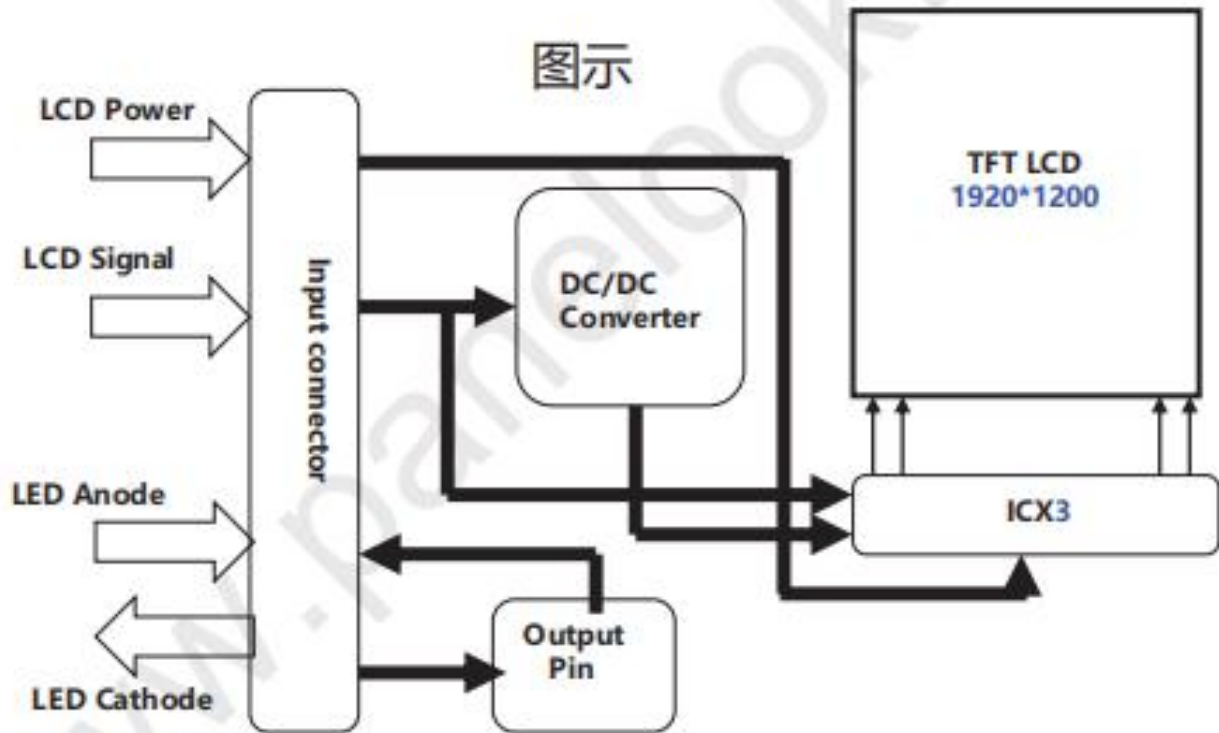

File NO.

REV

A/01

http://www.yes-display.com

3. Outline Dimensions

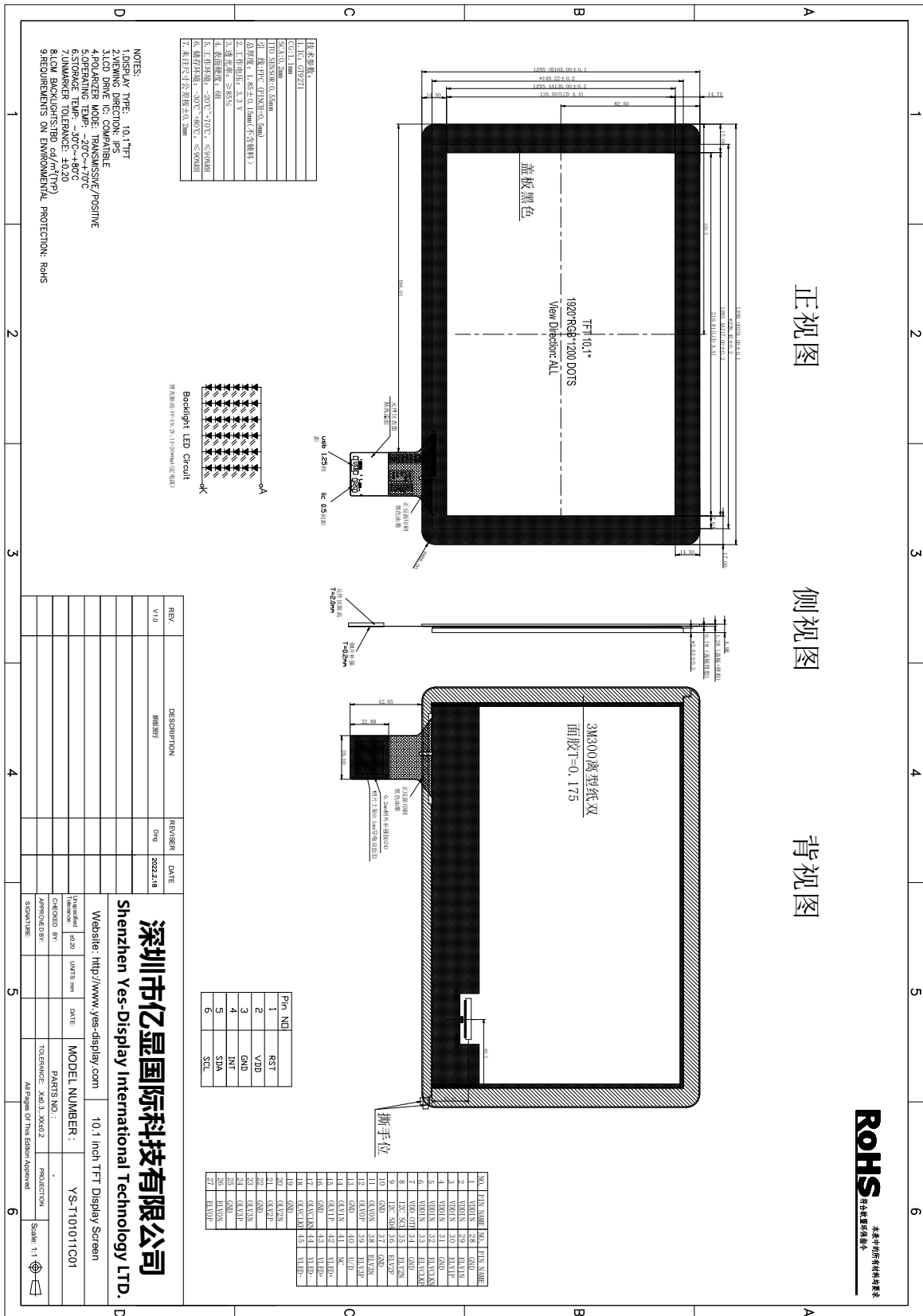

RoHS 本表中所有材料均符合
RoHS 环保标准

4. Input terminal Pin Assignment Description

4.1 TFT Pin Description

PIN NO.	PIN NAME	DESCRIPTION
1	VDDIN	Power supply VDDIN=3.3V
2	VDDIN	Power supply VDDIN=3.3V
3	VDDIN	Power supply VDDIN=3.3V
4	VDDIN	Power supply VDDIN=3.3V
5	VDDIN	Power supply VDDIN=3.3V
6	VDDIN	Power supply VDDIN=3.3V
7	VDD_OTP	Reserved for LCD manufacturer' s use , not connection
8	I2C _SCL	Reserved for LCD manufacturer' s use , not connection
9	I2C _SDA	Reserved for LCD manufacturer' s use , not connection
10	GND	GROUND
11	OLV0N	Odd LVDS Negative data signal (-)
12	OLV0P	Odd LVDS Positive data signal (+)
13	GND	GROUND
14	OLV1N	Odd LVDS Negative data signal (-)
15	OLV1P	Odd LVDS Positive data signal (+)
16	GND	GROUND
17	OLVCLKN	Odd LVDS Negative CLK signal (-)
18	OLVCLKP	Odd LVDS Positive CLK signal (+)
19	GND	GROUND
20	OLV2N	Odd LVDS Negative data signal (-)
21	OLV2P	Odd LVDS Positive data signal (+)
22	GND	GROUND
23	OLV3N	Odd LVDS Negative data signal (-)
24	OLV3P	Odd LVDS Positive data signal (+)
25	GND	GROUND
26	ELV0N	EVEN LVDS Negative data signal (-)
27	ELV0P	EVEN LVDS Positive data signal (+)

File NO.

REV

A/01

<http://www.yes-display.com>

28	GND	GROUND
29	ELV1N	EVEN LVDS Negative data signal (-)
30	ELV1P	EVEN LVDS Positive data signal (+)
31	GND	GROUND
32	ELVCLKN	EVEN LVDS Negative CLK signal (-)
33	ELVCLKP	EVEN LVDS Positive CLK signal (+)
34	GND	GROUND
35	ELV2N	EVEN LVDS Negative data signal (-)
36	ELV2P	EVEN LVDS Positive data signal (+)
37	GND	GROUND
38	ELV3N	EVEN LVDS Negative data signal (-)
39	ELV3P	EVEN LVDS Positive data signal (+)
40	GND	GROUND
41	NC	NC
42	VLED+	LED Anode
43	VLED+	LED Cathode
44	VLED-	LED Cathode
45	VLED-	LED Cathode

4.2 TP Pin Description

PIN NO.	PIN NAME	DESCRIPTION
1	RST	External Reset, Low is active
2	VDD	Power supply voltage
3	GND	System power ground.
4	INT	External interrupt to the host
5	SDA	I2C data input and output
6	SCL	I2C clock input

5. LCD Optical Characteristics

5.0 OPTICAL SPECIFICATIONS

5.1 Overview

TBD

The test of optical specifications shall be measured in a dark room (ambient luminance ≤ 1 lux and temperature = $25 \pm 2^\circ\text{C}$) with the equipment of Luminance meter system (Gonio meter system and TOPCON BM-5) and test unit shall be located at an approximate distance 50cm from the LCD surface at a viewing angle of θ and ϕ equal to 0° . We refer to $\theta\phi = 0 (= \theta 3)$ as the 3 o' clock direction (the "right"), $\theta\phi = 90 (= \theta 12)$ as the 12 O' clock direction ("upward"), $\theta\phi = 180 (= \theta 9)$ as the 9 O' clock direction ("left") and $\theta\phi = 270 (= \theta 6)$ as the 6 O' clock direction ("bottom"). While scanning θ and/or ϕ , the center of the measuring spot on the Display surface shall stay fixed.

5.2 Optical Specifications

Item	Symbol	Condition	Min	Typ.	Max	Unit	Note
Viewing Angle	θ_L	$Cr \geq 10$	70	80	--	deg	Note 1
	θ_R		70	80	--		
	ψ_T		70	80	--		
	ψ_B		70	80	--		
Contrast Ratio	Cr	$\theta = 0^\circ$	700	900		-	Note 2
Response Time	$T_r + T_f$	$FF = 0^\circ$	--	30	35	ms	Note 3
Color Coordinate of CIE1931	Rx	$\theta = 0^\circ$		--		-	Note 4
	Ry			--			
	Gx			--			
	Gy			--			
	Bx			--			
	By			--			
	Wx			--			
	Wy			--			
NTSC Ratio	NTSC	CIE1931	--	72	--	%	@BOE BLU Note 5
Gamma	-	-	1.9	2.2	2.5		Note 6
Polarization Direction of Front Polarizer	PdF	-		0		deg	Absorption axis Note 7
Polarization Direction of Rear Polarizer	PdR	-		90		deg	

Note 1: The definition of Viewing Angle
Refer to the graph below marked by θ and ϕ .

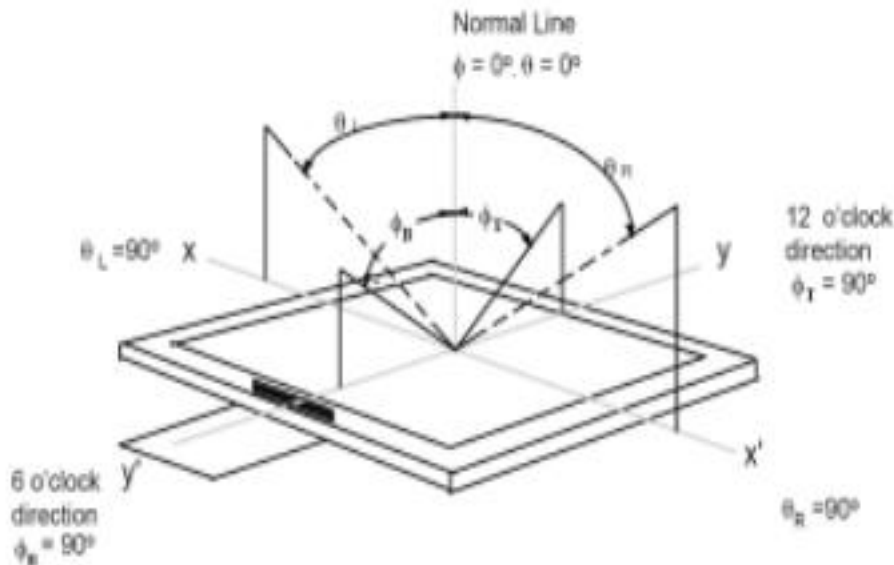

Note 2: The definition of Contrast Ratio

$$\text{Contrast Ratio (CR)} = \frac{\text{Luminance When LCD is at "White" state}}{\text{Luminance When LCD is at "Black" state}}$$

(Contrast Ratio is measured in optimum common electrode voltage)

Note 3: Definition of Response time. (Test LCD using RD80S or similar equipments):

The output sign also photo detector are measured when the input sign also are changed from "black" to "white" (Voltage falling time) and from "white" to "black" (Voltage rising time), respectively. The response time is defined as the time interval between the 10% and 90% of amplitudes. Refer to figures below.

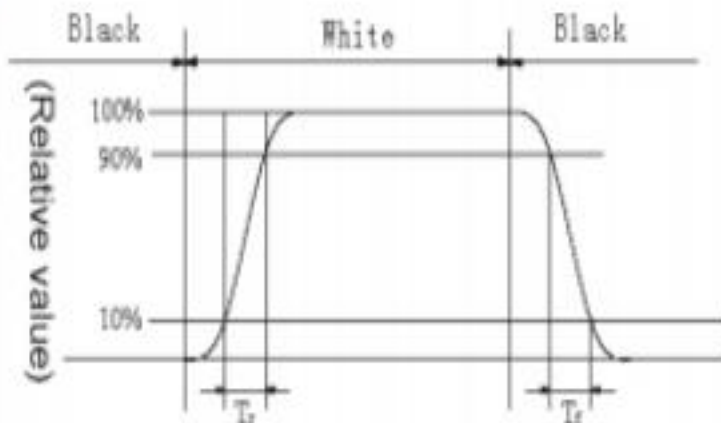

Note 4: Color Coordinates of CIE 1931

The test condition is at ILED=20mA and measured on the surface of LCD module at 25°C.

Measurement equipment: CS2000 or similar equipments

The Color Coordinate (CIE 1931) is the measurement of the center of the display shown in below figure.

Note 5: Definition of Color of CIE Coordinate and NTSC Ratio.

$$S = \frac{\text{area of RGB triangle}}{\text{area of NTSC triangle}} \times 100\%$$

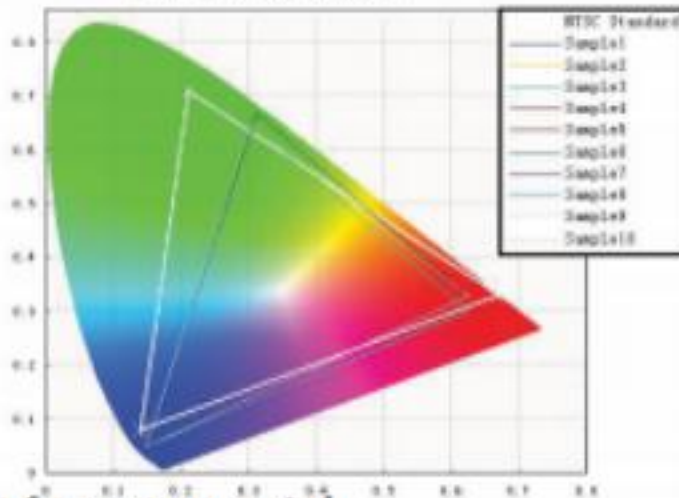

Note 6: gamma curve control

●For gamma curve control, HUAWEI' s request as below:

- 1,the whole curve' s tolerance must control within +/-0.3, HUAWEI will test the gray scale below:
0, 8, 16, 25, 33, 41, 49, 58, 66, 74, 82, 90, 99, 107, 115, 123, 132, 140, 148, 156, 165, 173, 181, 189, 197, 206, 214, 222, 230, 239, 247, 255

Note 7: Polarization Direction Definition

- Viewing direction is normal user viewing direction which is vertical to the display surface
- The polarizer which is closer to viewer is defined as Front Polarizer
- The polarizer which is on the rear side of viewer is defined as Rear Polarizer
- The X axis is defined as parallel line to top & bottom sidelines of the Active Area
- PdF which is marked in blue arrow is polarization degree of front polarizer
- PdR which is marked in red arrow is polarization degree of Back polarizer
- The polarization degree parameter must be indicated in range of 0deg to 180deg according to above definition

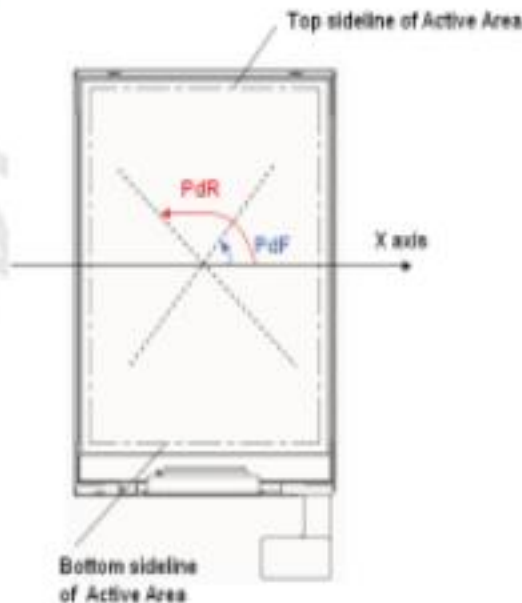

深圳市亿显国际科技有限公司 ShenZhen Yes-Display International Technology CO.,LTD.			10.1 寸液晶显示屏 10.1 Inch LCD Display Screen	
File NO.		REV	A/01	http://www.yes-display.com

6. TFT Electrical Characteristics

6.1 Absolute Maximum Ratings

Item	Symbol	Min.	Max.	Unit
TFT Power supply voltage	VDD	-0.3	3.6	V
	AVDD	6.5	13.5	V
	VGH	-0.3	42	V
	VGL	-20	0.3	V
CTP Logic Voltage	IOVCI	1.8	3.6	V
CTP Analog Voltage	VDD	-0.3	3.6	V
Operating Temperature	TOP	-20	80	°C
Storage Temperature	TST	-30	80	°C
Storage Humidity	HD	20	90	%RH

6.2 DC Characteristics

Item	Symbol	Min.	Typ.	Max.	Unit	Remark
TFT Power Supply Voltage	VDD	2.5	3.3	3.6	V	-
	AVDD	9.5	9.6	9.7	V	-
	VGH	16.5	18	20.3	V	-
	VGL	-6.4	-6.0	-5.6	V	-
CTP Logic Voltage	IOVCI	1.8	-	3.3	V	-
CTP Analog Voltage	VDD	2.8	-	3.3	V	-
Input signal Voltage	VCOM	3.6	4.2	4.4	V	

6.3 LED Backlight Characteristics

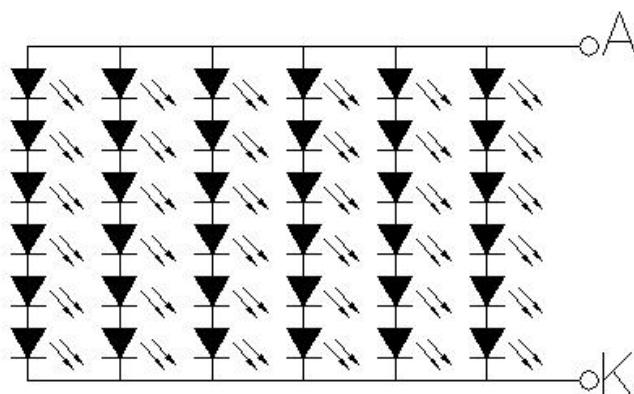

File NO.

REV

A/01

<http://www.yes-display.com>

Item	Symbol	MIN	TYP	MAX	UNIT	Test Condition
Supply Voltage	Vf	16.2	18	21	V	If=120mA
Supply Current	If	-	180	-	mA	-
Luminous Intensity for LCM	-	-	-	-	cd/m ²	If=120mA
Uniformity for LCM	-	-	60	-	%	If=120mA
Life Time	-	-	50000	-	Hr	If=120mA
Backlight Color	White					

7. Timing Characteristics

7.1 Interface timing Parameter

Parameter	Symbol	Value			Unit
		Min.	Typ.	Max.	
DCLK Frequency	Fdclk	71.6	74.1	85	MHz
Horizontal display area	Thd	960			DCLK
HSYNC period time	Th	989	1002	1248	DCLK
HSYNC pulse width	Thp	10	12	255	DCLK
HSYNC back porch	thbp	5	16	255	DCLK
HSYNC Front porch	thfp	24	26	260	DCLK
Vertical display area	Tvd	1200			H
VSYNC period time	Tv	1207	1232	1560	H
VSYNC Pluse width	Tvp	1	3	20	H
VSYNC back porch	Tvbp	2	24	255	H
VSYNC front porch	Tvfp	5	8	260	H
Frequency	fV	-	60	-	Hz

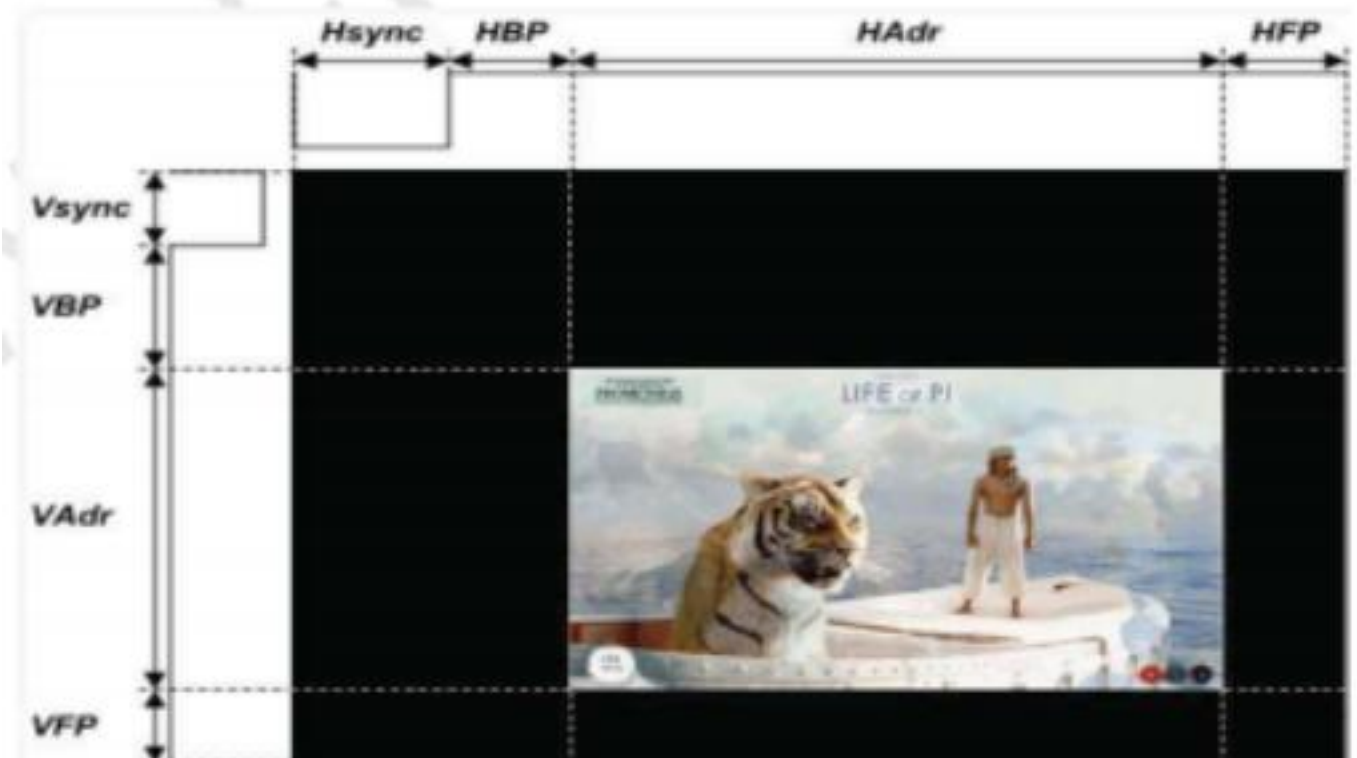

7.2 Power Sequence

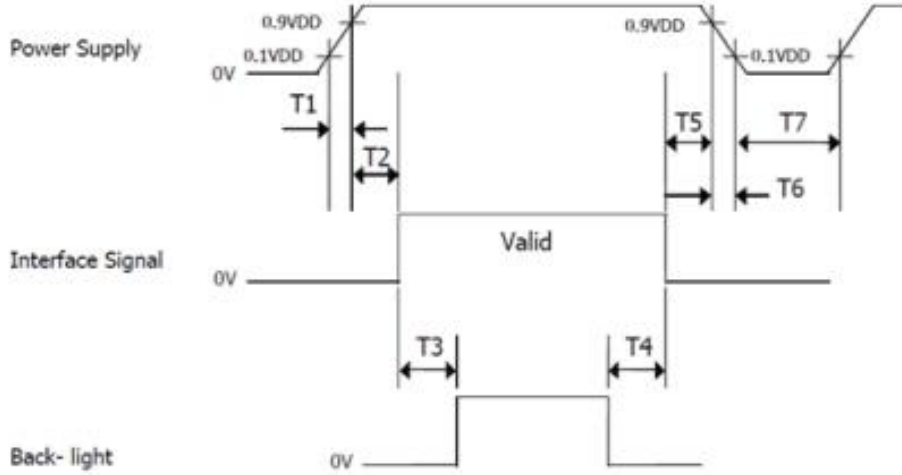

< Table6. Sequence Table >

Parameter	Values			Units
	Min	Typ	Max	
T1	0	-	10	ms
T2	0	-	50	ms
T3	200	-	-	ms
T4	500	-	-	ms
T5	0	-	50	ms
T6	0	-	10	ms
T7	500	-	-	ms

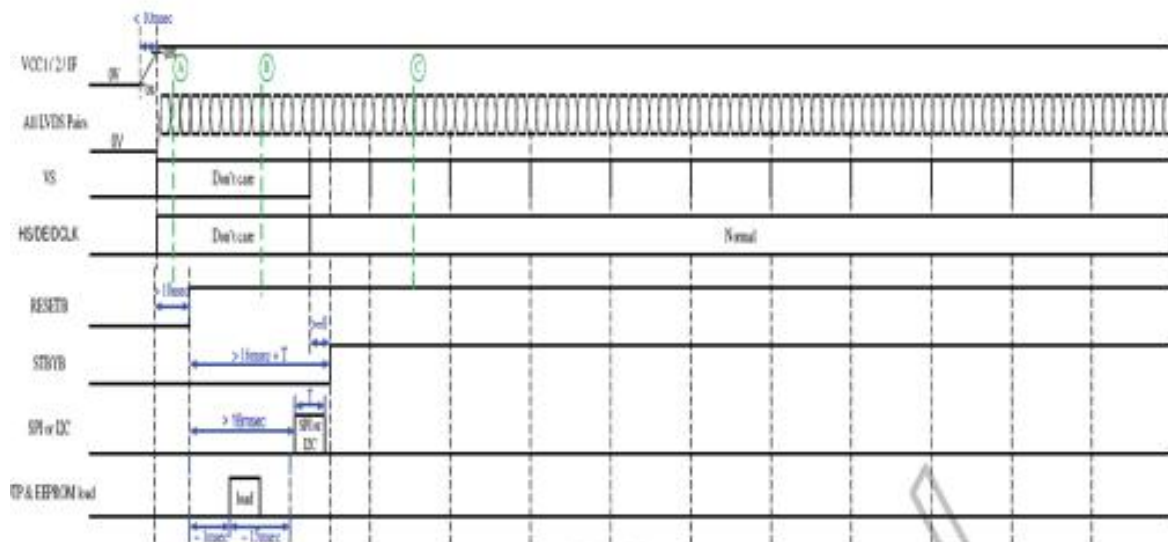

深圳市亿显国际科技有限公司 ShenZhen Yes-Display International Technology CO.,LTD.			10.1 寸液晶显示屏 10.1 Inch LCD Display Screen	
File NO.		REV	A/01	http://www.yes-display.com

8. Inspection Standard

8.1 Incoming Inspection and Standard:

The below incoming inspection are applied to the TFT LCM Modules supplied by ShenZhen Yes-Display International Technology CO.,LTD. The customers should inspect the LCM within 14 days after receiving the goods. The result of inspection should be notified to the Seller in the writing copy promptly, if the customer do not send them within 14 days, the seller has the right to judge as acceptance of goods. The inspection lot size is treated as the quantity per shipment and per model. The sampling plan shall be inspected under MIL-STD015E in Level II by single sampling. The acceptable quality level (AQL) are categorized as below grades:

CRITICAL= 0.4%, MAJOR= 0.65%, MINOR= 1.5%

8.2 Inspection condition and Warranty policy:

The delivered LCM should be stored properly, ideally under climate-controlled environment at 25 (±5) degree Celsius as well as 60% (±10) Relative Humidity. The LCM shall be inspected in the viewing angle of 45 degree from the four major angles (U/D/L/R) under the single fluorescent lamp of 20W (equal to 300 to 500 lux). For warranty, ShenZhen Yes-Display International Technology CO.,LTD. will provide 12 months of warranty period as standard, and provide the new replacement for the defective products which belong to the Seller's responsibility verified by the quality department.

8.3 Inspection Criteria:

8.3.1 Critical defect

Item No.	Inspection content	Judgement
8.3.1.1	Functional defects	No display, abnormal display, short circuit, missing line, off-contrast and chromaticity, Touch Panel non-function
8.3.1.2	Model mixed	Other model mixed

8.3.2 Major defect:

Item No.	Inspection content	Judgement
8.3.2.1	Product indication	Missing model no. and wrong model no. is indicated on the LCM.
8.3.2.2	Glass cracking	The LCD and touch panel glass crack or breakage

深圳市亿显国际科技有限公司 ShenZhen Yes-Display International Technology CO.,LTD.			10.1 寸液晶显示屏 10.1 Inch LCD Display Screen	
File NO.		REV	A/01	http://www.yes-display.com

8.3.2.3	Missing component	The function component missing such as connector, cable, etc.
---------	-------------------	---

8.3.3 Minor defect (LCD) :

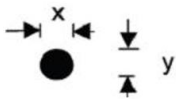
Item No.	Inspection content	Judgement												
8.3.3.1	Black/White spot Foreign particles Dust in the cell	$\varphi = (x+y) / 2$  <table border="1"> <thead> <tr> <th>Diameter (mm)</th> <th>Acceptable Q'ty</th> </tr> </thead> <tbody> <tr> <td>$\Phi \leq 0.1$</td> <td>Ignore</td> </tr> <tr> <td>$0.1 < \Phi \leq 0.25$</td> <td>3 (Distance>5mm)</td> </tr> <tr> <td>$0.25 < \Phi$</td> <td>Not allowed</td> </tr> </tbody> </table>	Diameter (mm)	Acceptable Q'ty	$\Phi \leq 0.1$	Ignore	$0.1 < \Phi \leq 0.25$	3 (Distance>5mm)	$0.25 < \Phi$	Not allowed				
Diameter (mm)	Acceptable Q'ty													
$\Phi \leq 0.1$	Ignore													
$0.1 < \Phi \leq 0.25$	3 (Distance>5mm)													
$0.25 < \Phi$	Not allowed													
8.3.3.2	Linear defect Black/white line Black/white scratch	<table border="1"> <thead> <tr> <th>Length(mm)</th> <th>Width (mm)</th> <th>Acceptable Q'ty</th> </tr> </thead> <tbody> <tr> <td></td> <td>$W \leq 0.03$</td> <td>Ignore</td> </tr> <tr> <td>$L \leq 5.0$</td> <td>$0.03 < W \leq 0.07$</td> <td>3</td> </tr> <tr> <td></td> <td>$0.07 < W$</td> <td>Follow 8.3.3.1</td> </tr> </tbody> </table>	Length(mm)	Width (mm)	Acceptable Q'ty		$W \leq 0.03$	Ignore	$L \leq 5.0$	$0.03 < W \leq 0.07$	3		$0.07 < W$	Follow 8.3.3.1
Length(mm)	Width (mm)	Acceptable Q'ty												
	$W \leq 0.03$	Ignore												
$L \leq 5.0$	$0.03 < W \leq 0.07$	3												
	$0.07 < W$	Follow 8.3.3.1												
8.3.3.3	Polarizer Bubbles Dent on polarizer	<table border="1"> <thead> <tr> <th>Diameter (mm)</th> <th>Acceptable Q'ty</th> </tr> </thead> <tbody> <tr> <td>$\Phi \leq 0.2$</td> <td>Ignore</td> </tr> <tr> <td>$0.2 < \Phi \leq 0.5$</td> <td>2 (Distance>5mm)</td> </tr> <tr> <td>$0.5 < \Phi$</td> <td>Not allowed</td> </tr> </tbody> </table>	Diameter (mm)	Acceptable Q'ty	$\Phi \leq 0.2$	Ignore	$0.2 < \Phi \leq 0.5$	2 (Distance>5mm)	$0.5 < \Phi$	Not allowed				
Diameter (mm)	Acceptable Q'ty													
$\Phi \leq 0.2$	Ignore													
$0.2 < \Phi \leq 0.5$	2 (Distance>5mm)													
$0.5 < \Phi$	Not allowed													

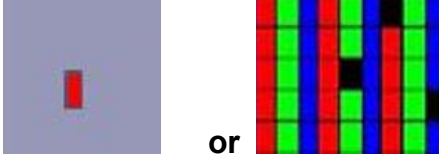
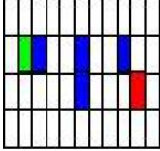
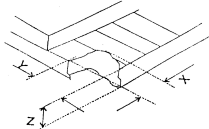
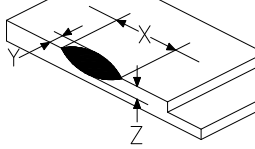
<p>8.3.3.4</p>	<p>Electrical Defect Dot</p>	<p>Bright dot and Dark dot definition:</p>  <p>or</p>  <p>(Two adjacent dot)</p> <p>Inspection pattern: black, white, red, green, and blue screen.</p> <table border="1" data-bbox="730 730 1441 913"> <thead> <tr> <th>Items</th> <th>Acceptable Q'ty</th> </tr> </thead> <tbody> <tr> <td>Bright dot</td> <td>$N \leq 4$ (Distance >5mm)</td> </tr> <tr> <td>Dark dot</td> <td>$N \leq 4$ (Distance >5mm)</td> </tr> </tbody> </table>	Items	Acceptable Q'ty	Bright dot	$N \leq 4$ (Distance >5mm)	Dark dot	$N \leq 4$ (Distance >5mm)
Items	Acceptable Q'ty							
Bright dot	$N \leq 4$ (Distance >5mm)							
Dark dot	$N \leq 4$ (Distance >5mm)							
<p>8.3.3.5</p>	<p>Glass Defect- Corner chipping</p>	 <table border="1" data-bbox="730 1104 1441 1375"> <thead> <tr> <th>Size(mm)</th> <th>Judgement</th> </tr> </thead> <tbody> <tr> <td> $X \leq 3\text{mm}$, $Y \leq S$, $Z \leq T$ (S= ITO length, T=Single glass thickness) </td> <td>Accept</td> </tr> </tbody> </table>	Size(mm)	Judgement	$X \leq 3\text{mm}$, $Y \leq S$, $Z \leq T$ (S= ITO length, T=Single glass thickness)	Accept		
Size(mm)	Judgement							
$X \leq 3\text{mm}$, $Y \leq S$, $Z \leq T$ (S= ITO length, T=Single glass thickness)	Accept							
<p>8.3.3.6</p>	<p>Glass Defect- Side fragment</p>	 <table border="1" data-bbox="730 1574 1441 1787"> <thead> <tr> <th>Size(mm)</th> <th>Judgement</th> </tr> </thead> <tbody> <tr> <td> $X \leq 2\text{ mm}$, $Y \leq \text{border edge}$ $Z \leq T$ (T= single glass thickness) </td> <td>Accept</td> </tr> </tbody> </table>	Size(mm)	Judgement	$X \leq 2\text{ mm}$, $Y \leq \text{border edge}$ $Z \leq T$ (T= single glass thickness)	Accept		
Size(mm)	Judgement							
$X \leq 2\text{ mm}$, $Y \leq \text{border edge}$ $Z \leq T$ (T= single glass thickness)	Accept							

8.3.4 Minor defect (Touch Panel)

Item No.	Inspection content	Judgement
----------	--------------------	-----------

File NO.

REV

A/01

<http://www.yes-display.com>

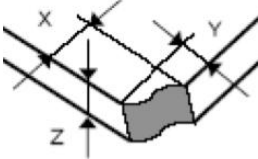
8.3.4.1	Scratch, dust, particles, foreign materials in "linear type"	Size (mm)	Acceptable Q'ty
		$W \leq 0.05\text{mm}, L \leq 10\text{mm}$	Ignore
		$0.05\text{mm} < W \leq 0.07\text{mm}, L \leq 10\text{mm}$	3
		$W > 0.07\text{mm}$	Reject
8.3.4.2	Scratch, dust, particles, foreign materials in "round type"	Diameter (mm)	Acceptable Q'ty
		$\Phi \leq 0.25\text{mm}$	Ignore
		$0.25\text{mm} < \Phi \leq 0.35\text{mm}$	5
		$\Phi > 0.35\text{mm}$	Reject
8.3.4.3	Air bubbles	Diameter (mm)	Acceptable Q'ty
		$\Phi \leq 0.2\text{mm}$	Ignore
		$0.2\text{mm} < \Phi \leq 0.5\text{mm}$	3
		$\Phi > 0.5\text{mm}$	Reject
8.3.4.5	Scratch on printing area	Size (mm)	Acceptable Q'ty
		$W \leq 0.03\text{mm}, L \leq 5\text{mm}$	Ignore
		$0.03\text{mm} < W \leq 0.05\text{mm}, L \leq 5\text{mm}$	3
		$W > 0.05\text{mm}$ or $L > 5\text{mm}$	Reject
8.3.4.6	Corner chipping		
		Size(mm)	Judgement
		$X \leq 2\text{mm}, Y \leq 2\text{mm}$ $Z < 1/2T$ (T= single glass thickness)	Accept

File NO.

REV

A/01

<http://www.yes-display.com>

8.3.4.7

Edge chipping

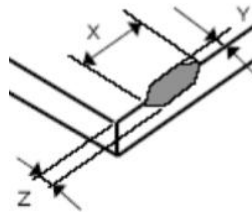

Size(mm)	Judgement
$X \leq 3 \text{ mm}, Y \leq 3 \text{ mm}$ $Z \leq 1/2 T$ (T= single glass thickness)	Accept

深圳市亿显国际科技有限公司 ShenZhen Yes-Display International Technology CO.,LTD.			10.1 寸液晶显示屏 10.1 Inch LCD Display Screen	
File NO.		REV	A/01	http://www.yes-display.com

9. Reliability Test Conditions and Methods

9.1 Reliability Test Conditions and Methods:

NO.	TEST ITEMS	TEST CONDITION	INSPECTION AFTER TEST
①	High Temperature Storage	80°C±2°C×96Hours	Inspection after 2~4hours storage at room temperature, the samples should be free from defects: 1, Air bubble in the LCD. 2, Seal leak. 3, Non-display. 4, Missing segments. 5, Glass crack. 6, Current IDD is twice higher than initial value. 7, The surface shall be free from damage. 8, The electric characteristic requirements shall be satisfied.
②	Low Temperature Storage	-30°C±2°C×96Hours	
③	High Temperature Operating	70°C±2°C×96Hours	
④	Low Temperature Operating	-20°C±2°C×96Hours	
⑤	Temperature Cycle(Storage)	-20°C ↔ 25°C ↔ 70°C (30min) ← (5min) → (30min) 1cycle Total 10cycle	
⑥	Damp Proof Test (Storage)	50°C±5°C×90%RH×96Hours	
⑦	Vibration Test	Frequency:10Hz~55Hz~10Hz Amplitude:1.5MM X,Y,Z direction for total 3hours (packing condition test will be tested by a carton)	
⑧	Drooping Test	Drop to the ground from 1M height one time every side of carton. (packing condition test will be tested by a carton)	
⑨	ESD Test	Voltage:±8KV,R:330Ω,C:150PF,Air Mode,10times	

深圳市亿显国际科技有限公司 ShenZhen Yes-Display International Technology CO.,LTD.			10.1 寸液晶显示屏 10.1 Inch LCD Display Screen	
File NO.		REV	A/01	http://www.yes-display.com

REMARK:

- 1, The Test samples should be applied to only one test item.
- 2, Sample side for each test item is 5~10pcs.
- 3, For Damp Proof Test, Pure water(Resistance > 10MΩ) should be used.
- 4, In case of malfunction defect caused by ESD damage, if it would be recovered to normal state after resetting, it would be judge as a good part.
- 5, EL evaluation should be accepted from reliability test with humidity and temperature: Some defects such as black spot/blemish can happen by natural chemical reaction with humidity and Fluorescence EL has.
- 6, Failure Judgment Criterion: Basic Specification Electrical Characteristic, Mechanical Characteristic, Optical Characteristic.

深圳市亿显国际科技有限公司 ShenZhen Yes-Display International Technology CO.,LTD.			10.1 寸液晶显示屏 10.1 Inch LCD Display Screen	
File NO.		REV	A/01	http://www.yes-display.com

10. Cautions and Handling Precautions

10.1 Mounting method

The LCD panel of TFT module consists of two thin glass plates with polarizes which easily be damaged. And since the module in so constructed as to be fixed by utilizing fitting holes in the printed circuit board.

Extreme care should be needed when handling the LCD modules.

10.2 Caution of LCD handling and cleaning

When cleaning the display surface, Use soft cloth with solvent

[Recommended below] and wipe lightly

- Isopropyl alcohol
- Ethyl alcohol

Do not wipe the display surface with dry or hard materials that will damage the polarizer surface.

Do not use the following solvent:

- Water
- Aromatics

Do not wipe ITO pad area with the dry or hard materials that will damage the ITO patterns

Do not use the following solvent on the pad or prevent it from being contaminated:

- Soldering flux
- Chlorine (Cl) , Sulfur (S)

If goods were sent without being silicon coated on the pad, ITO patterns could be damaged due to the corrosion as time goes on.

If ITO corrosion happen by miss-handling or using some materials such as Chlorine (Cl), Sulfur (S) from customer, Responsibility is on customer.

10.3 Caution against static charge

The LCD module use C-MOS LSI drivers, so we recommended that you:

Connect any unused input terminal to power or ground, do not input any signals before power is turned on, and ground your body, work/assembly areas, and assembly equipment to protect against static electricity.

深圳市亿显国际科技有限公司 ShenZhen Yes-Display International Technology CO.,LTD.			10.1 寸液晶显示屏 10.1 Inch LCD Display Screen	
File NO.		REV	A/01	http://www.yes-display.com

10.4 packing

- Module employs LCD elements and must be treated as such.
- Avoid intense shock and falls from a height.
- To prevent modules from degradation, do not operate or store them exposed direct to sunshine or high temperature/humidity

10.5 Caution for operation

- It is an indispensable condition to drive LCD's within the specified voltage limit since the higher voltage then the limit cause the shorter LCD life.
- An electrochemical reaction due to direct current causes LCD's undesirable deterioration, so that the use of direct current drive should be avoided.
- Response time will be extremely delayed at lower temperature then the operating temperature range and on the other hand at higher temperature LCD's how dark color in them. However those phenomena do not mean malfunction or out of order with LCD's, which will come back in the specified operation temperature.
- If the display area is pushed hard during operation, some font will be abnormally displayed but it resumes normal condition after turning off once.
- Slight dew depositing on terminals is a cause for electro-chemical reaction resulting in terminal open circuit.

Usage under the maximum operating temperature, 50%Rh or less is required.

10.6 storing

In the case of storing for a long period of time for instance, for years for the purpose or replacement use, the following ways are recommended.

- Storage in a polyethylene bag with the opening sealed so as not to enter fresh air outside in it. And with no desiccant.
- Placing in a dark place where neither exposure to direct sunlight nor light's keeping the storage temperature range.
- Storing with no touch on polarizer surface by the anything else.

[It is recommended to store them as they have been contained in the inner container at the time of delivery from us

10.7 Safety

- It is recommendable to crash damaged or unnecessary LCD's into pieces and wash off liquid crystal by either of solvents such as acetone and ethanol, which should be burned up later.

深圳市亿显国际科技有限公司 ShenZhen Yes-Display International Technology CO.,LTD.			10.1 寸液晶显示屏 10.1 Inch LCD Display Screen	
File NO.		REV	A/01	http://www.yes-display.com

- When any liquid leaked out of a damaged glass cell comes in contact with your hands, please wash it off well with soap and water

11. Packing Method

11.1 Method

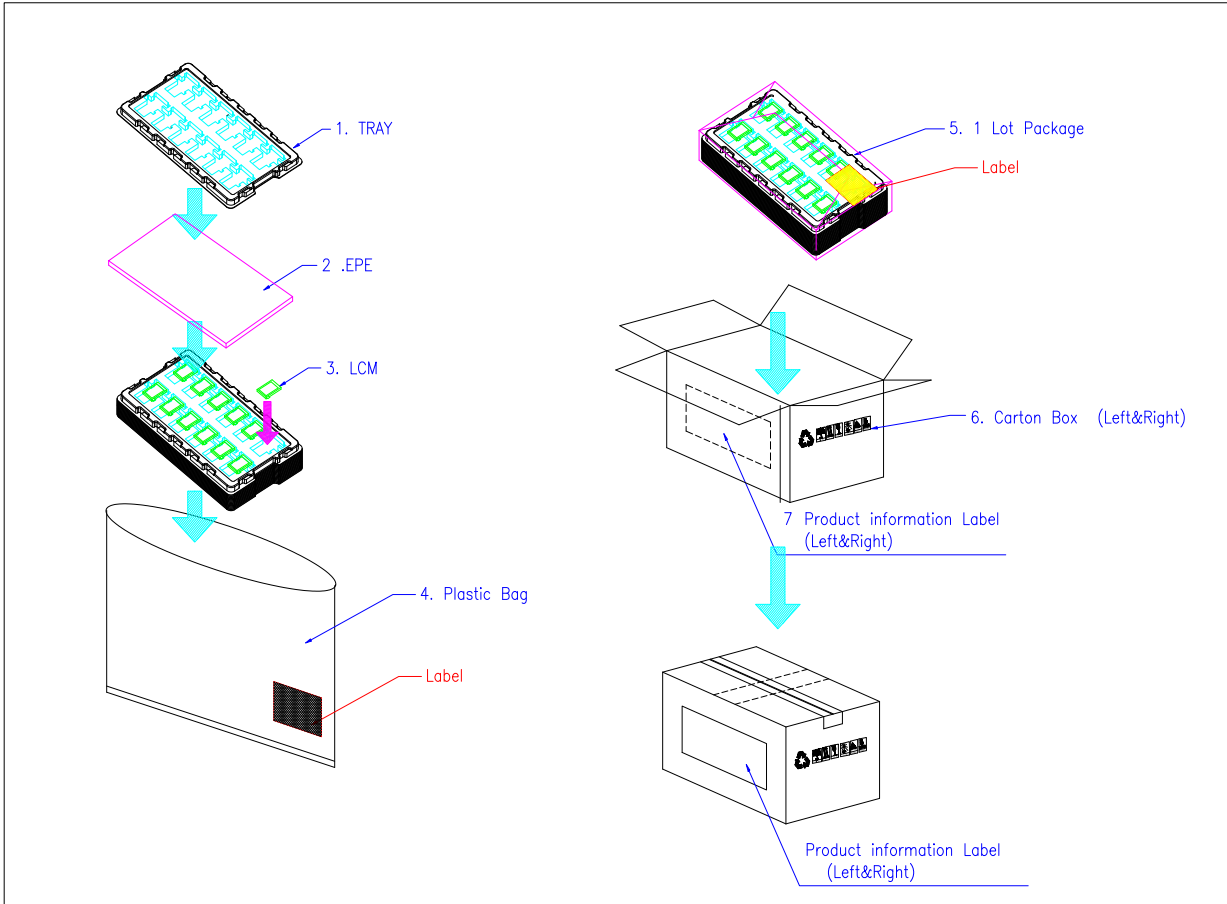

11.2 Packing Label

TBD