

样品承认书

客户: _____

客户料号: 21.5寸模组1000亮度版本: A0料号: HV215FHM-1000日期: 2019.05.20

	制作	检查	审核	质量保证
客户	检查	审核	质量保证	

料号		制定	研发部	文件编号	
客户料号	21.5 模组	制定日期	2019.05.20	版本	A
目录					
一：产品规格 (1~4)					3~5
二：光学特性检测 (5)					5
三：质量标准 (6)					6
6-1. 尺寸规格					6
6-2. 电气特性					6
6-3. 外观检查					7
四：可靠性检测 (7)					8
五：检查标准 (8)					9
六：包装及标志 (9)					10
七：其它 (10~16)					10~11
八：附件 1：成品图					12
九：附件 2：材料清单					13
十：附件 3：包装材料清单					14
十一：附件 4：亮度尺寸测试报告					15
备注：产品规格承认书中的所有数据均基于 光电的仪器测得。					

料号		制定	研发部	文件编号	
客户料号	21.5 模组	制定日期	2019.05.20	版本	A

开发履历

日期	具体内容与原因	更改编号	修改人

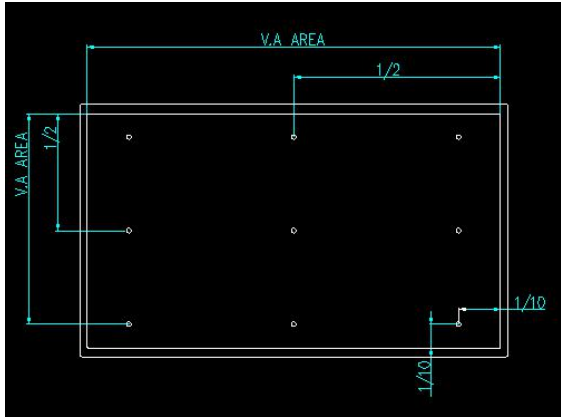
料号		制定	研发部	文件编号	
客户料号	21.5 模组	制定日期	2019.05.20	版本	A0
1. 用途：本规格针对本产品出具 2. 产品：模组 3. 产品规格编号： 客户型号：21.5 模组 4. 形状和尺寸 形状和尺寸如图所示。 5. 光学特性检测					
编号	项目	检测方法			
1	光学均匀性	将镜头放置在距“模组”表面 350 mm 处。			
		使用亮度计 (CHROMA) 检测“模组”表面亮度。			
		检测条件：VF=54V(TYP) IF=300mA			
		检测环境：	室内温度：23±4℃ 湿度：50±20%RH 光照度：200LUX 以下		
		检测距离：	350 mm		
		角度：	1°		
		检测点：	9 点		
	检测点位置：				
2	中心亮度	测试方法和上述单点方法相同，仅检测一点。			
		测试点：1 点			
		测试位置：仅在 ⑤ 位置			
3	均匀性	均匀性= (最小亮度/最大亮度) x 100% ≥ 75%			

6. 质量标准

检测项目与合格范围：

6-1. 尺寸规格（对比图纸尺寸）

- (1). 检测设备：2.5 次元测量系统、卡尺等。。
- (2). 判断标准：尺寸检测结果应在图纸所标的公差范围内。
- (3). 检测量。
 1. 外观检查：根据 MIL-STD-105E Level-II 一般检验，单次抽样 MAJ:0.25 MIN:0.65
 2. 尺寸：2 PCS
 3. 亮度：2 PCS。

6-2. 电气特性（背光）

(1)

项目	符号	数值	单位
正向电流	IF	300	mA
反向电压	VR		V
消耗功率	PO		W
工作温度	Topr	0 至 +50	°C
贮存温度	Tstg	-30 至 +60	°C
耐焊时间	3sec	330（最大）	°C

(2)

项目	符号	最小值	典型值	最大值	单位	条件
亮度	IV	---	1000	---	cd/m ²	IF=300mA TA=25 °C
色度坐标值	X	---	(0.313)	---	---	
	Y	---	(0.329)	---	---	
正向电压	VF	---	54	---	V	
反向电流	IR	---	---	--	mA	

*测试设备：误差范围：亮度 +/-5%，色度 +/-0.005。

料号		制定	研发部	文件编号	
客户料号	21.5 模组	制定日期	2019.05.20	版本	A0

(3)

项目	内容	备注
均匀性	参见光学特性检测	温度：25±4℃
(1) 检测设备	参见光学均匀性的检测标准	
(2) 检测标准	参见光学均匀性的检测标准	
(3) 评判标准	均匀性在要求的规范内	

6-3. 外观检查

点亮标准：

检查距离：**30±5 cm。**

检查照度：**150±50Lux。**

画质检查规范 (共通) 出货检查实施项目(点灯外观)

点灯规格 (组好玻璃)

NO	项 目	规 格 (mm)	容许数量
1	点状异物、白点、侧白点、Sheet 刮伤(盖上 Panel) (刮伤严重以线状异物判定)	D<0.2 (注 1)	不计
		0.2≦D≦0.5	需≦3 个且距离需超 15mm
		D>0.5	不可有
		异物盖上 Cell 可见 NG,不可见 OK	
2	线状异物、侧白	0.01≦W<0.15 , 0.3≦L<1	N≦2
		W>0.15	以点状异物、侧白判定
3	目视确认有无颜色不均, 辉度不均(明暗部、亮线、暗线、漏光、翘曲)	依据限度样本	

在 windows 桌面上不可见的点或异物判定为合格。

料号		制定	研发部	文件编号	
客户料号	21.5 模组	制定日期	2019.05.20	版本	A0

7. 可靠性检测

检测	项目	检测条件	时间	评判标准单位（：件数）
寿命测试	1. 连续工作	Ta=25℃	320 小时	亮度平均衰减率 △%≦20% VF 差异 △%≦5% 如无异常显示即为正常。
	2. 高温贮存	Tstg=+60℃	320 小时	
	3. 低温贮存	Tstg=-20℃	320 小时	
	4. 高温高湿存放	Topr=70℃ & RH=90%	320 小时	
	5. 冷热冲击	Tstg: (-20℃ 至 +60℃), 每次 10 分钟。	50 次	
	6. 温度循环测试	Tstg: (-20℃ 至 +60℃), 每次 30 分钟。	100 次	

料号		制定	研发部	文件编号	
客户料号	21.5 模组	制定日期	2019.05.20	版本	A0

8. 检查标准

检查与评判标准

为了确定产品是否符合客户的要求，我们根据以下所列项执行检查（检查结果将在发货产品中随附）。

项目	规格	检测周期	检测方法	评判标准
形状和尺寸	如图纸所示	每一批次	卡尺与投影仪等	(0, 1)
外观	参见外观检测	每一批次	参见外观检测	参见外观检测
光学特性	参见光学特性检测	每一批次	参见光学特性检测	(0, 1)
可靠性检测	参见可靠性检测	针对第一批次或规格更改的条件下	参见可靠性检测	(0, 1)

8. 包装及标志

1. 准备纸箱



2. 下方放入两个珍珠棉，一个格子放一片，（产品套 PE 袋）



3. 一个纸箱装 5 片（放两片示意），然后上面再加两个珍珠棉，最后封箱。



9-2. 包装形式图



封箱，然后装卡板出货

10. 机密文档

光电与客户均不得向无关部门或个人透露产品相关的机密文档、图纸和其它内容。

11. 有效期

本产品规格承认书自发布之日起生效，直至我司或客户对任何规格做出修改并实施为止。

12. 安全说明（不含有毒或危险材料）

产品符合 ROHS，在加工过程中未使用任何含溴物质。

13. 产品贮藏应符合以下条件：

如本产品需贮藏较长时间（六个月内），则贮藏温度应维持在 $14^{\circ}\text{C}\sim 26^{\circ}\text{C}$ 之间。同时，湿度应维持在 $30\%\sim 60\%$ 之间。

料号		制定	研发部	文件编号	
客户料号	21.5 模组	制定日期	2019.05.20	版本	A0

14 关于静电

本产品对静电敏感，因而在处置时应特别小心。

特别是在电压超过产品绝对最大定额值的情况下。

溢出能量作用可能导致产品损坏或损毁。

- a. 为预防静电，建议操作人员绝缘 ($1M\Omega$)，例如穿着防静电手套和鞋具。
- b. 所有设备与机器应电气接地，在地面上铺放导电垫。建议在容易产生静电的设施或环境下设立电离链路。
- c. 同时采取措施，预防静电进入整体驱动电路。

15. 其它：如客户对本产品规格承认书存有任何疑问，均可与我方在相互协商与定义的前提下确定相关解决方案。



附件 1：成品图

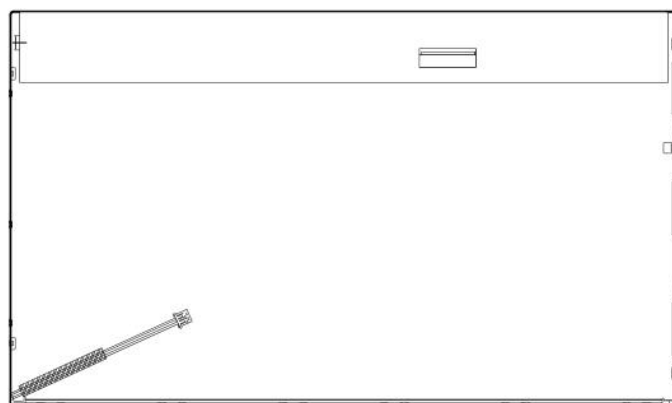
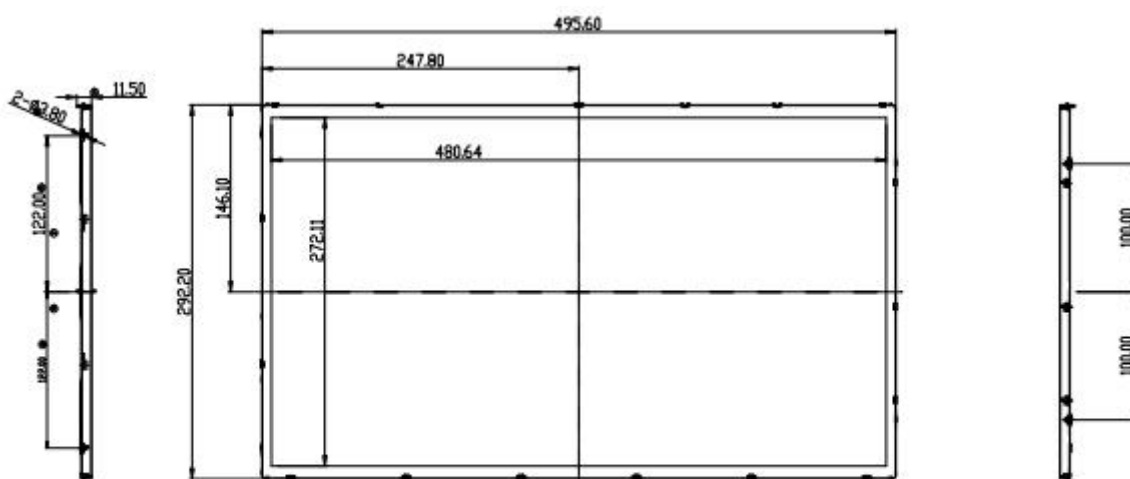

附件 2:

材料清单

序号	材料名称	材质	用量	备注
1	前框+背板	SGCC	1	
2	反射片		1	
3	导光板		1	
4	下散		1	
5	DBEF		1	
6	胶框	PC+玻纤	1	
7	增光		2	
8	LED		72	
9	PCB 板	铝基板	1	
10	导热胶		1	
11	端子		1	2 PIN 标准端子
12	麦拉	PET+黑/白胶	1	
13	液晶玻璃		1	BOE

附件 3:

包装材料清单

1. 纸箱

2.珍珠棉，一箱配4个

附件 4：亮度及尺寸报告

《样品检验报告与各项指标》											
客户料号			样品数	2			检验日期				
			检验数				直通率测算				
各区亮度测试	电源提供仪器	兆信所产RXN-605D型号测试仪	测试背光板区间及均值								
			部分区间	第一片	第二片	第三片	平均值				
			顶左上点	460	449		第一片：均匀度 79%	检验员			
			顶部中点	467	465						
			顶右上点	464	464						
	亮度测试仪器	专业背光源测试仪	中左下点	496	502		第二片：均匀度 80%	检验判定	■合格 □不合格		
			中部中点	578	569						
			中右下点	493	514						
			底左下点	480	508		备注				
			底部中点	499	479						
底右下点	478	501									
背光板的尺寸	成品尺寸	测试工具为：直尺	长度	495.6m m	±0.5	背光配比玻璃情况	<input type="checkbox"/> TMS	检验员			
			宽度	292.2m m	±0.5		<input checked="" type="checkbox"/> BOE	检验判定	合格		
			厚度	11.5m m	±0.3		<input type="checkbox"/> CMO	备注			
背光板电压、电流测试情况			最小	典型	最大	单位					
	电流			300	320	mA					
	电压		-	54	--	V					
	功率		-	16.2	--	W					
备注	两 PIN										
品质确认		工程确认		检验		审核		批准			

OC 参数:

1.0 GENERAL DESCRIPTION

1.1 Introduction

MV215FHB-N31 is a color active matrix TFT LCD module using amorphous silicon TFT's (Thin Film Transistors) as an active switching devices. This module has a 21.5 inch diagonally measured active area with FHD resolutions (1920 horizontal by 1080 vertical pixel array). Each pixel is divided into RED, GREEN, BLUE dots which are arranged in vertical stripe and this module can display 16.7M colors. The TFT-LCD panel used for this module is adapted for a low reflection and higher color type.

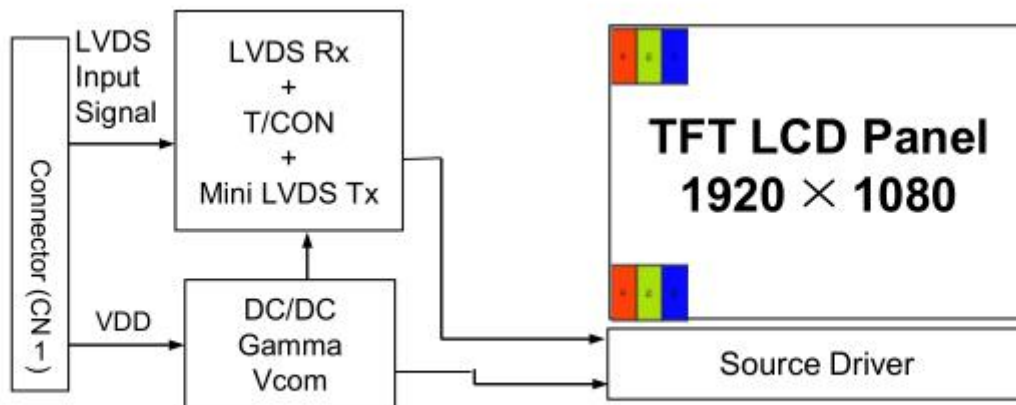

1.2 Features

- LVDS Interface with 2 pixel / clock
- High-speed response
- 0.5t Glass
- 6-bit (Hi-FRC) color depth, display 16.7M colors
- Incorporated edge type back-light (One Light Bar)
- High luminance and contrast ratio, low reflection and wide viewing angle
- DE (Data Enable) only
- RoHS/Halogen Free
- ES 7.0 compliant
- Gamma Correction
- Reverse type

1.3 Application

- Desktop Type of PC & Workstation Use
- Slim-Size Display for Stand-alone Monitor
- Display Terminals for Control System
- Monitors for Process Controller

1.4 General Specification

The followings are general specifications at the model MV215FHB-N30.

<Table 1. General Specifications>

Parameter	Specification	Unit	Remarks
Active area	476.064(H) × 267.786(V)	mm	Diagonal: 546.211mm
Number of pixels	1920(H) × 1080(V)	pixels	
Pixel pitch	0.24795(H) x 0.24795(V)	mm	
Pixel arrangement	RGB Vertical stripe	-	
Display colors	16.7M	colors	
Display mode	Normally Black	-	
Open Cell Transmittance	5.6(Typ.)	%	
Dimensional outline	483.646(H) × 278.676(V) typ.	mm	Detail refer to drawing
Weight	0.4(Simulation)	Kg	
Surface Treatment	Anti-glare, 3H	-	
Power Consumption	P_D : 6w (max)		@75HZ

2.0 ABSOLUTE MAXIMUM RATINGS

The followings are maximum values which, if exceeded, may cause faulty operation or damage to the unit. The operational and non-operational maximum voltage and current values are listed in Table 2.

< Table 2. Absolute Maximum Ratings > [VSS=GND=0V]

Parameter	Symbol	Min.	Max.	Unit	Remarks
Power Supply Voltage	V_{DD}	-0.3	5.5	V	Ta = 25 °C
Logic Supply Voltage	V_{IN}	VSS-0.3	$V_{DD}+0.3$	V	
Operating Temperature	T_{OP}	0	+50	°C	1)
Storage Temperature	T_{ST}	-20	+60	°C	1)

Note : 1) Temperature and relative humidity range are shown in the figure below.
Wet bulb temperature should be 39 °C max. and no condensation of water.

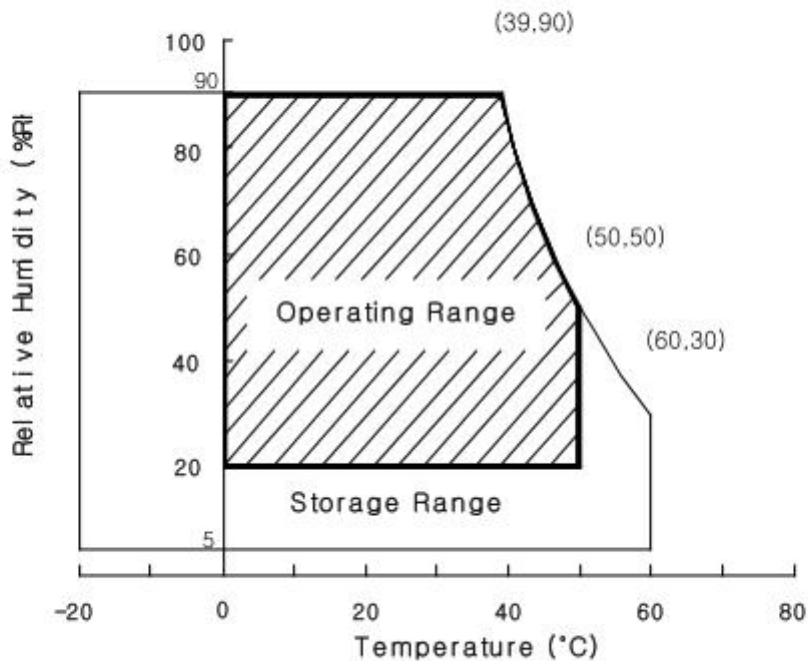

3.0 ELECTRICAL SPECIFICATIONS

3.1 Electrical Specifications

< Table 3. Electrical specifications >

[Ta = 25 ± 2 °C]

Parameter		Min.	Typ.	Max.	Unit	Remarks
Power Supply Voltage	V _{DD}	4.5	5.0	5.5	V	Note 1
Power Supply Current	I _{DD}	-	500	1200	mA	
In-Rush Current	I _{RUSH}	-	2.0	3.0	A	Note 2
Permissible Input Ripple Voltage	V _{RF}	-	-	300	mV	Note 1,3
High Level Differential Input Threshold Voltage	V _{IH}	-	-	+100	mV	
Low Level Differential Input Threshold Voltage	V _{IL}	-100	-	-	mV	
Differential input voltage	V _{ID}	200	-	600	mV	
Differential input common mode voltage	V _{cm}	1.0	1.2	1.5		V _{IH} =100mV, V _{IL} =-100mV
Power Consumption	P _D	-	2.5	6	W	

Notes : 1. The supply voltage is measured and specified at the interface connector of LCM.
The current draw and power consumption specified is for VDD=5.0V, Frame rate=75Hz
Clock frequency = 92.9 MHz. Test Pattern of power supply current

- a) Typ : Color Test
- b) Max : Vertical Subline255

- 2. Duration of rush current is about 2 ms and rising time of VDD is 520 μs ± 20 %
- 3. Ripple Voltage should be covered by Input voltage Spec.

4.0 OPTICAL SPECIFICATION

4.1 Overview

The test of Optical specifications shall be measured in a dark room (ambient luminance ≤ 1 lux and temperature = $25 \pm 2^\circ\text{C}$) with the equipment of Luminance meter system (Goniometer system and TOPCONE PR730) and test unit shall be located at an approximate distance 50cm from the LCD surface at a viewing angle of θ and Φ equal to 0° . We refer to θ_{0-0} ($=\theta_3$) as the 3 o'clock direction (the "right"), θ_{0-90} ($=\theta_{12}$) as the 12 o'clock direction ("upward"), θ_{0-180} ($=\theta_9$) as the 9 o'clock direction ("left") and θ_{0-270} ($=\theta_6$) as the 6 o'clock direction ("bottom"). While scanning θ and/or Φ , the center of the measuring spot on the Display surface shall stay fixed. The measurement shall be executed after 30 minutes warm-up period. VDD shall be 5.0V +/-10% at 25°C . Optimum viewing angle direction is 6 'clock.

4.2 Optical Specifications

[VDD = 5.0V, Frame rate = 60Hz, Clock = 74MHz, $I_{BL} = 160\text{mA}$, $T_a = 25 \pm 2^\circ\text{C}$]

< Table 4. Module Optical >

Parameter		Symbol	Condition	Min.	Typ.	Max.	Unit	Remark
Viewing Angle range	Horizontal	θ_3	CR > 10	85	89	-	Deg.	Note 1
		θ_9		85	89	-	Deg.	
	Vertical	θ_{12}		85	89	-	Deg.	
		θ_6		85	89	-	Deg.	
Luminance Contrast ratio		CR		700	1000			Note 2
Cell Transmittance		Tr		-	5.6	-	%	Note 3
Reproduction of color	White	W_x	$\theta = 0^\circ$ (Center) Normal Viewing Angle	0.283	0.313	0.343	-	Note 4
		W_y		0.299	0.329	0.359	-	
	Red	R_x		0.609	0.639	0.669	-	
		R_y		0.327	0.357	0.387	-	
	Green	G_x		0.279	0.309	0.339	-	
		G_y		0.608	0.638	0.668	-	
	Blue	B_x		0.122	0.152	0.182	-	
		B_y		0.039	0.069	0.099	-	
Response Time	GTG	T_g			14	20	ms	Note 5
Cross Talk		CT		-	-	2.0	%	Note 6

Note :

1. Viewing angle is the angle at which the contrast ratio is greater than 10. The viewing are determined for the horizontal or 3, 9 o'clock direction and the vertical or 6, 12 o'clock direction with respect to the optical axis which is normal to the LCD surface.
2. Contrast measurements shall be made at viewing angle of $\theta= 0^\circ$ and at the center of the LCD surface. Luminance shall be measured with all pixels in the view field set first to white, then to the dark (black) state. (See FIGURE 1 shown in Appendix) Luminance Contrast Ratio (CR) is defined mathematically.

$$CR = \frac{\text{Luminance when displaying a white raster}}{\text{Luminance when displaying a black raster}}$$

3. Center Luminance of white is defined as the LCD surface. Luminance shall be measured with all pixels in the view field set first to white. This measurement shall be taken at the locations shown in FIGURE 2 for a total of the measurements per display.
4. The White luminance uniformity on LCD surface is then expressed as :
 $\Delta Y = (\text{Minimum Luminance of 9points} / \text{Maximum Luminance of 9points}) * 100$
 (See FIGURE 2 shown in Appendix).
5. The color chromaticity coordinates specified in Table 5. shall be calculated from the spectral data measured with all pixels first in red, green, blue and white. Measurements shall be made at the center of the panel.
6. Response time T_g is the average time required for display transition by switching the input signal as below table and is based on Frame rate $f_V = 60\text{Hz}$ to optimize. Each time in below table is defined as appendix Figure 3 and shall be measured by switching the input signal for “any level of gray(bright)” and “any level of gray(dark)”.

Measured Response Time	Target																	
	0	15	31	47	63	78	95	111	127	143	158	175	191	207	223	239	255	
0																		
15																		
31																		
47																		
63																		
78																		
95																		
111																		
127																		
143																		
158																		
175																		
191																		
207																		
223																		
239																		
255																		

7. Cross-Talk of one area of the LCD surface by another shall be measured by comparing the luminance (Y_A) of a 25mm diameter area, with all display pixels set to a gray level, to the luminance (Y_B) of that same area when any adjacent area is driven dark. (See FIGURE 4 shown in Appendix).

5.0 INTERFACE CONNECTION.

5.1 Electrical Interface Connection

- CN11 Module Side Connector : UJU IS100-L30R-C23or Equivalent
User Side Connector : JAE FI-X30H or Equivalent

Pin No	Symbol	Function	Remark
1	RXO0-	Negative Transmission data of Pixel 0 (ODD)	
2	RXO0+	Positive Transmission data of Pixel 0 (ODD)	
3	RXO1-	Negative Transmission data of Pixel 1 (ODD)	
4	RXO1+	Positive Transmission data of Pixel 1 (ODD)	
5	RXO2-	Negative Transmission data of Pixel 2 (ODD)	
6	RXO2+	Positive Transmission data of Pixel 2 (ODD)	
7	BIST	Bist function	Note1
8	RXOC-	Negative Transmission Clock (ODD)	
9	RXOC+	Positive Transmission Clock (ODD)	
10	RXO3-	Negative Transmission data of Pixel 3 (ODD)	
11	RXO3+	Positive Transmission data of Pixel 3 (ODD)	
12	RXE0-	Negative Transmission data of Pixel 0 (EVEN)	
13	RXE0+	Positive Transmission data of Pixel 0 (EVEN)	
14	GND	Power Ground	
15	RXE1-	Negative Transmission data of Pixel 1 (EVEN)	
16	RXE1+	Positive Transmission data of Pixel 1 (EVEN)	
17	GNG	Power Ground	
18	RXE2-	Negative Transmission data of Pixel 2 (EVEN)	
19	RXE2+	Positive Transmission data of Pixel 2 (EVEN)	
20	RXEC-	Negative Transmission Clock (EVEN)	
21	RXEC+	Positive Transmission Clock (EVEN)	
22	RXE3-	Negative Transmission data of Pixel 3 (EVEN)	
23	RXE3+	Positive Transmission data of Pixel 3 (EVEN)	

24	GND	Power Ground	Note 2
25	CTL	*Reserved for LCD manufacturer's(CTL_DVR)	
26	CE	*Reserved for LCD manufacturer's(CE_DVR)	
27	NC		
28	VDD	Power Supply: +5V	
29	VDD		
30	VDD		

Note 1 : H: White-Black-Red-Green-Blue Pattern Aging, L:Black pattern,when no LVDS signal

Note2: This pin should be connected with GND.

5.2 LVDS Interface (Tx; THC63LVDF83A or Equivalent)

5.2.1 LVDS Interface

	Input Signal	Transmitter		Interface		MV215FHB-N30 (CN11)	Remark
		Pin No.	Pin No.	System (Tx)	TFT-LCD (Rx)	Pin No.	
L V D S	OR0	51	48 47	OUT0- OUT0+	RXO0- RXO0+	1 2	
	OR1	52					
	OR2	54					
	OR3	55					
	OR4	56					
	OR5	3					
	OG0	4	46 45	OUT1- OUT1+	RXO1- RXO1+	3 4	
	OG1	6					
	OG2	7					
	OG3	11					
	OG4	12					
	OG5	14					
	OB0	15	42 41	OUT2- OUT2+	RXO2- RXO2+	5 6	
OB1	19						
OB2	20						
OB3	22						
OB4	23						
OB5	24						
Hsync	27	CLK		RXO			
Vsync	28						
DE	30	40 39		OUT- CLK	CLK- RXO	8 9	
MCLK	31						
OR6	50	38 37		OUT3- OUT3+	RXO3- RXO3+	10 11	
OR7	2						
OG6	8						
OG7	10						
OB6	16						
OB7	18						
RSVD	25						

6.0 SIGNAL TIMING SPECIFICATION

6.1 The MV215FHB-N30 is operated by the DE only.

Item	Symbols		Min	Typ	Max	Unit	Note
DCLK	Period	tCLK	11.1	13.47	16.7	ns	
	Frequency	-	60	74	90	MHz	
Hsync	Period	tHP	1050	1100	1120	tCLK	
	Horizontal Valid	tHV	960	960	960	tCLK	
	Horizontal Blank	tHB	90	140	160		
	Frequency	fH	64	67	83	KHz	
Vsync	Period	tVP	1110	1125	1251	tHP	
	Vertical Valid	tVV	1080	1080	1080	tHP	
	Vertical Blank	tVB	30	45	171	tHP	
	Frequency	fV	50	60	75	Hz	
LVDS Receiver clock	Input spread spectrum ratio	SSr	-3	-	+3	%	

Note 1 : This DCLK range at last line of V-blanking should be set in 0~987.

6.2 LVDS Rx Interface Timing Parameter

The specification of the LVDS Rx interface timing parameter is shown in Table 4.

<Table 4. LVDS Rx Interface Timing Specification>

Item	Symbol	Min	Typ	Max	Unit	Remark
CLKIN Period	tRCIP	11.1	13.47	16.7	nsec	
Input Data 0	tRIP1	-0.4	0.0	+0.4	nsec	
Input Data 1	tRIP0	tRCIP/7-0.4	tRCIP/7	tRCIP/7+0.4	nsec	
Input Data 2	tRIP6	2 × tRCIP/7-0.4	2 × tRCIP/7	2 × tRCIP/7+0.4	nsec	
Input Data 3	tRIP5	3 × tRCIP/7-0.4	3 × tRCIP/7	3 × tRCIP/7+0.4	nsec	
Input Data 4	tRIP4	4 × tRCIP/7-0.4	4 × tRCIP/7	4 × tRCIP/7+0.4	nsec	
Input Data 5	tRIP3	5 × tRCIP/7-0.4	5 × tRCIP/7	5 × tRCIP/7+0.4	nsec	
Input Data 6	tRIP2	6 × tRCIP/7-0.4	6 × tRCIP/7	6 × tRCIP/7+0.4	nsec	

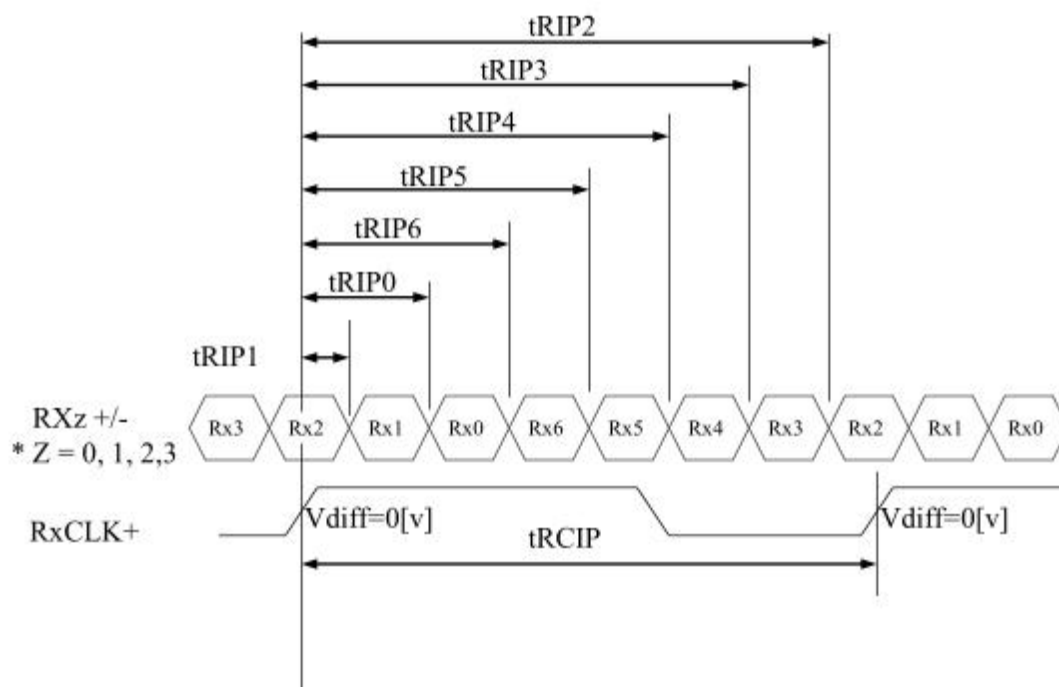

* Vdiff = (RXz+) - (RXz-), ..., (RXCLK+) - (RXCLK-)

7.0 SIGNAL TIMING WAVEFORMS OF INTERFACE SIGNAL

7.1 Sync Timing Waveforms

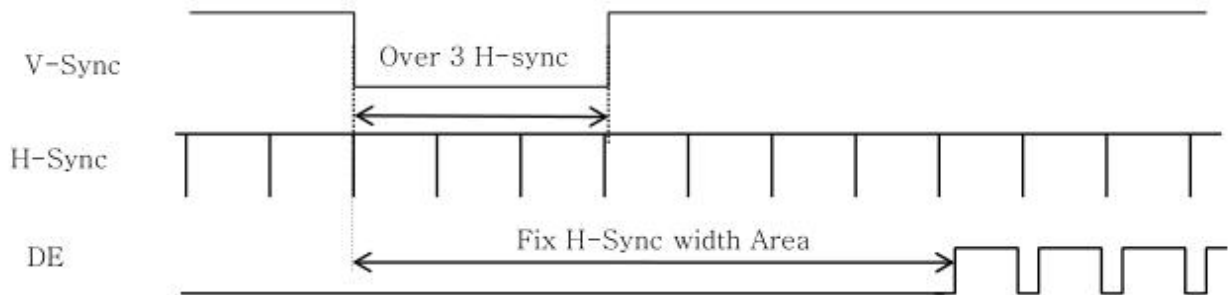

- 1) Need over 3 H-sync during V-Sync Low
- 2) Fix H-Sync width from V-Sync falling edge to first rising edge

7.2 Vertical Timing Waveforms

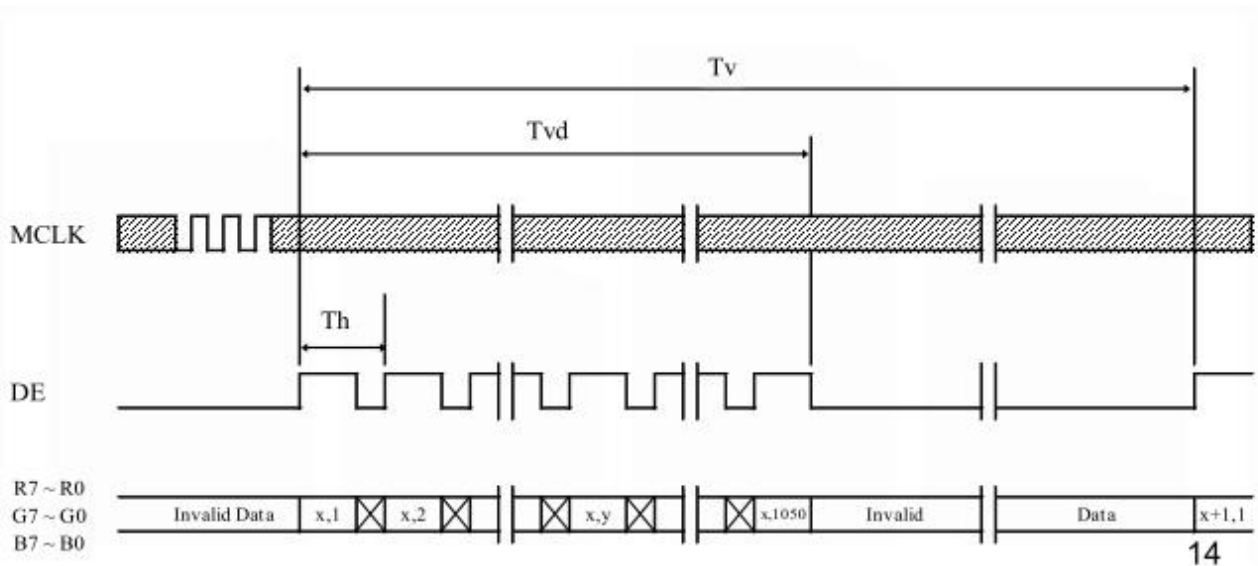

7.3 Horizontal Timing Waveforms

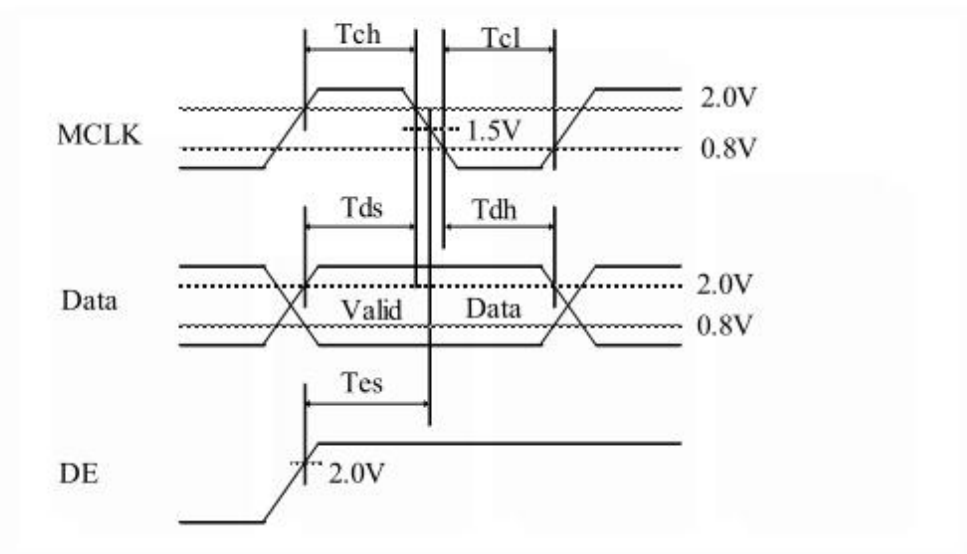
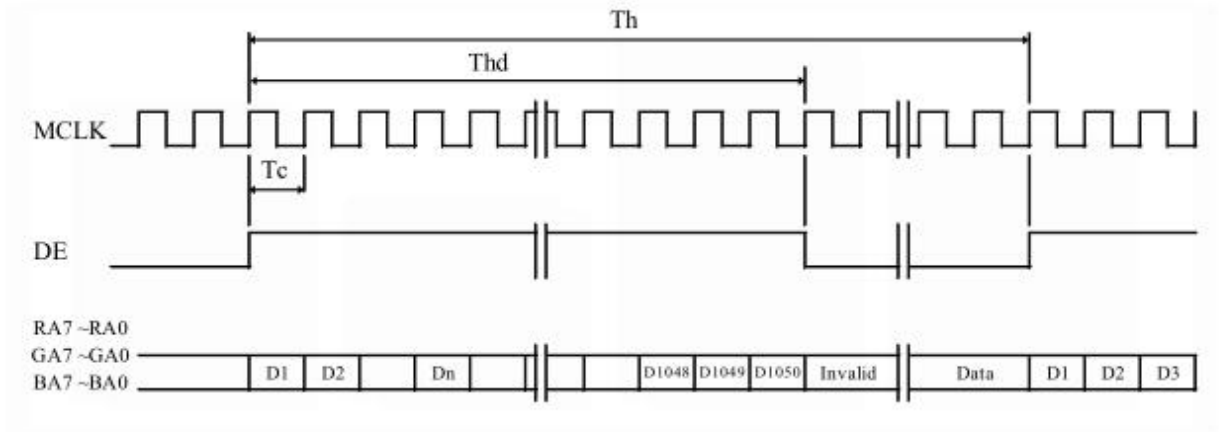

8.0 INPUT SIGNALS, BASIC DISPLAY COLORS & GRAY SCALE OF COLORS

Color & Gray Scale		RED DATA								GREEN DATA								BLUE DATA							
		R7	R6	R5	R4	R3	R2	R1	R0	G7	G6	G5	G4	G3	G2	G1	G0	B7	B6	B5	B4	B3	B2	B1	B0
Basic Colors	Black	0	0	0	0	0	0	0	0	0	0	0	0	0	0	0	0	0	0	0	0	0	0	0	0
	Blue	0	0	0	0	0	0	0	0	0	0	0	0	0	0	0	0	1	1	1	1	1	1	1	1
	Green	0	0	0	0	0	0	0	0	1	1	1	1	1	1	1	1	0	0	0	0	0	0	0	0
	Cyan	0	0	0	0	0	0	0	0	1	1	1	1	1	1	1	1	1	1	1	1	1	1	1	1
	Red	1	1	1	1	1	1	1	1	0	0	0	0	0	0	0	0	0	0	0	0	0	0	0	0
	Magenta	1	1	1	1	1	1	1	1	0	0	0	0	0	0	0	0	1	1	1	1	1	1	1	1
	Yellow	1	1	1	1	1	1	1	1	1	1	1	1	1	1	1	1	0	0	0	0	0	0	0	0
	White	1	1	1	1	1	1	1	1	1	1	1	1	1	1	1	1	1	1	1	1	1	1	1	1
Gray Scale of RED	Black	0	0	0	0	0	0	0	0	0	0	0	0	0	0	0	0	0	0	0	0	0	0	0	
	△	0	0	0	0	0	0	1	0	0	0	0	0	0	0	0	0	0	0	0	0	0	0	0	
	Darker	0	0	0	0	0	0	1	0	0	0	0	0	0	0	0	0	0	0	0	0	0	0	0	
	△	↑								↑															
	▽	↓								↓															
	Brighter	1	1	1	1	1	1	0	1	0	0	0	0	0	0	0	0	0	0	0	0	0	0	0	
	▽	1	1	1	1	1	1	0	0	0	0	0	0	0	0	0	0	0	0	0	0	0	0	0	
	Red	1	1	1	1	1	1	1	0	0	0	0	0	0	0	0	0	0	0	0	0	0	0	0	
Gray Scale of GREEN	Black	0	0	0	0	0	0	0	0	0	0	0	0	0	0	0	0	0	0	0	0	0	0		
	△	0	0	0	0	0	0	0	0	0	0	0	0	0	0	0	0	0	0	0	0	0	0		
	Darker	0	0	0	0	0	0	0	0	0	0	0	0	0	0	0	0	0	0	0	0	0	0		
	△	↑								↑															
	▽	↓								↓															
	Brighter	0	0	0	0	0	0	0	1	1	1	1	1	1	0	1	0	0	0	0	0	0	0		
	▽	0	0	0	0	0	0	0	1	1	1	1	1	1	0	0	0	0	0	0	0	0	0		
	Green	0	0	0	0	0	0	0	1	1	1	1	1	1	1	0	0	0	0	0	0	0	0		

Gray Scale of BLUE	Black	0	0	0	0	0	0	0	0	0	0	0	0	0	0	0	0	0	0	0	0	0	0
	△	0	0	0	0	0	0	0	0	0	0	0	0	0	0	0	0	0	0	0	0	0	1
	Darker	0	0	0	0	0	0	0	0	0	0	0	0	0	0	0	0	0	0	0	0	1	0
	△	↑								↑													
	▽	↓								↓													
	Brighter	0	0	0	0	0	0	0	0	0	0	0	0	0	0	1	1	1	1	1	1	0	1
	▽	0	0	0	0	0	0	0	0	0	0	0	0	0	0	1	1	1	1	1	1	1	0
	Blue	0	0	0	0	0	0	0	0	0	0	0	0	0	0	1	1	1	1	1	1	1	1
Gray Scale of WHITE	Black	0	0	0	0	0	0	0	0	0	0	0	0	0	0	0	0	0	0	0	0	0	0
	△	0	0	0	0	0	0	1	0	0	0	0	0	0	0	1	0	0	0	0	0	0	1
	Darker	0	0	0	0	0	0	1	0	0	0	0	0	0	1	0	0	0	0	0	0	1	0
	△	↑								↑													
	▽	↓								↓													
	Brighter	1	1	1	1	1	1	0	1	1	1	1	1	1	0	1	1	1	1	1	1	0	1
	▽	1	1	1	1	1	1	0	1	1	1	1	1	1	0	1	1	1	1	1	1	1	0
	White	1	1	1	1	1	1	1	1	1	1	1	1	1	1	1	1	1	1	1	1	1	1

9.0 POWER SEQUENCE

To prevent a latch-up or DC operation of the LCD module, the power on/off sequence shall be as shown in below

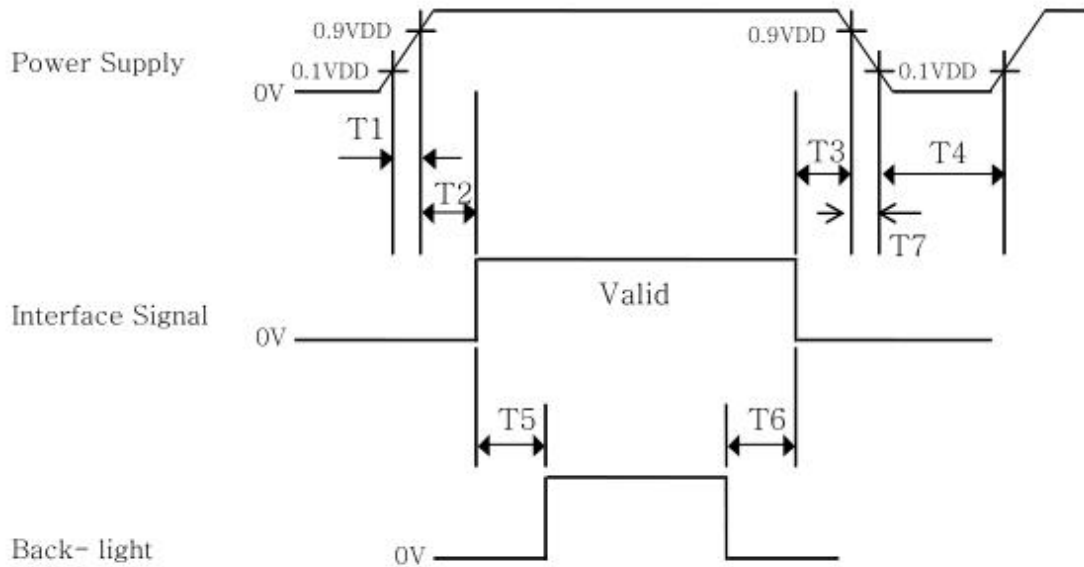

- $0.5 \text{ ms} \leq T1 \leq 10 \text{ ms}$
- $0 \leq T2 \leq 50 \text{ ms}$
- $0 \leq T3 \leq 50 \text{ ms}$
- $1 \text{ sec} \leq T4$
- $200 \text{ ms} \leq T5$
- $200 \text{ ms} \leq T6$

Notes:

1. When the power supply VDD is 0V, keep the level of input signals on the low or keep high impedance.
2. Do not keep the interface signal high impedance when power is on.
3. Back Light must be turn on after power for logic and interface signal are valid.
4. T7 decreases smoothly, there is none re-bouncing voltage.
5. The above power sequence should be satisfied at these case
 - AC/DC power On/Off
 - Mode Change (Resolution, frequency, timing, sleep mode, color depth change etc.)
 If not to follow power sequence, there is a risk of abnormal display.

10.0 MECHANICAL CHARACTERISTICS

10.1 Dimensional Requirements

FIGURE 5 (located in Appendix) shows mechanical outlines for the model MV215FHB-N30. Other parameters are shown in Table 8.

<Table 8. Dimensional Parameters>

Parameter	Specification	Unit
Weight	400(Simulation)	gram
Active area	476.064 (H) × 267.786 (V)	mm
Pixel pitch	0.24795(H) × 0.24795(V)	mm
Number of pixels	1920 (H) × 1080 (V) (1 pixel = R + G + B dots)	pixels

10.2 Mounting

See FIGURE 5 . (shown in Appendix)

10.3 Anti-Glare and Polarizer Hardness.

The surface of the LCD has an anti-glare coating to minimize reflection and a coating to reduce scratching.

10.4 Light Leakage

There shall not be visible light from the back-lighting system around the edges of the screen as seen from a distance 50cm from the screen with an overhead light level of 350lux.

11.0 RELIABILITY TEST

The Reliability test items and its conditions are shown in below.

<Table 9 Reliability Test Parameters >

No	Test Items	Conditions	
1	High temperature storage test	Ta = 60 °C, 240 hrs	
2	Low temperature storage test	Ta = -20 °C, 240 hrs	
3	High temperature & high humidity operation test	Ta = 50 °C, 80%RH, 240hrs	
4	High temperature operation test	Ta = 50 °C, 240hrs	
5	Low temperature operation test	Ta = 0°C, 240hrs	
6	Thermal shock	Ta = -20 °C ↔ 60 °C (0.5 hr), 100 cycle	
7	Vibration test (non-operating)	Frequency	Random, 10 ~ 300 Hz, 30 min/Axis
		Gravity / AMP	1.5 Grms
		Period	X, Y, Z 30 min
8	Shock test (non-operating)	Gravity	50G
		Pulse width	11msec, sine wave
		Direction	± X, ± Y, ± Z Once for each
9	Electro-static discharge test	Air : 150 pF, 330Ω, 15 KV	Contact : 150 pF, 330Ω, 8 KV

12.0 HANDLING & CAUTIONS

- (1) Cautions when taking out the module
 - Pick the pouch only, when taking out module from a shipping package.
- (2) Cautions for handling the module
 - As the electrostatic discharges may break the LCD module, handle the LCD module with care. Peel a protection sheet off from the LCD panel surface as slowly as possible.
 - As the LCD panel and back - light element are made from fragile glass material, impulse and pressure to the LCD module should be avoided.
 - As the surface of the polarizer is very soft and easily scratched, use a soft dry cloth without chemicals for cleaning.
 - Do not pull the interface connector in or out while the LCD module is operating.
 - Put the module display side down on a flat horizontal plane.
 - Handle connectors and cables with care.
- (3) Cautions for the operation
 - When the module is operating, do not lose CLK, ENAB signals. If any one of these signals is lost, the LCD panel would be damaged.
 - Obey the supply voltage sequence. If wrong sequence is applied, the module would be damaged.
- (4) Cautions for the atmosphere
 - Dew drop atmosphere should be avoided.
 - Do not store and/or operate the LCD module in a high temperature and/or humidity atmosphere. Storage in an electro-conductive polymer packing pouch and under relatively low temperature atmosphere is recommended.
- (5) Cautions for the module characteristics
 - Do not apply fixed pattern data signal to the LCD module at product aging.
 - Applying fixed pattern for a long time may cause image sticking.
- (6) Other cautions
 - Do not disassemble and/or re-assemble LCD module.
 - Do not re-adjust variable resistor or switch etc.
 - When returning the module for repair or etc., Please pack the module not to be broken. We recommend to use the original shipping packages.

Figure 3. Response Time Testing

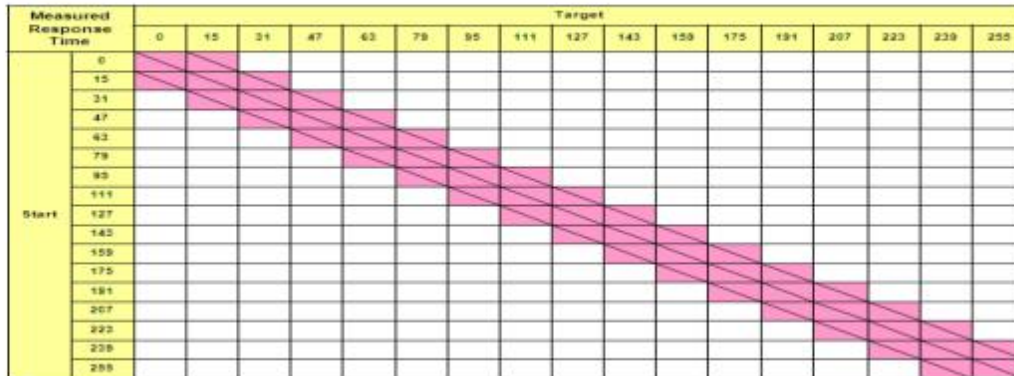
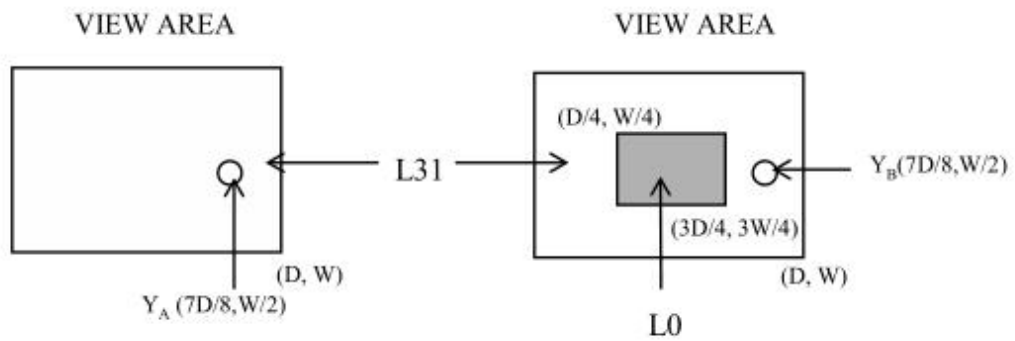

Figure 4. Cross Modulation Test Description



$$\text{Cross-Talk (\%)} = \left| \frac{Y_B - Y_A}{Y_A} \right| \times 100$$

Where: Y_A = Initial luminance of measured area (cd/m^2)

Y_B = Subsequent luminance of measured area (cd/m^2)

The location measured will be exactly the same in both patterns