

<h1 style="margin: 0;">承 认 印</h1> <h2 style="margin: 0;">Approved by</h2>	
审核:	确认:

客户确认结果:

Customer
客 户: _____

Product
品 名: _____ 10.1 寸 IPS 模组 _____

Part NO.
产品料号: _____ HDL101MP-31 _____

DATE
日 期: _____ 2019/11/10 _____

Approved 核 准	Checked 审 核	Prepared 制 作
		曾文

1.0 General Description

1.1 Introduction

HDL101MP-31 Display model 10.1" LCM is a color active matrix thin film transistor (TFT) liquid crystal display (LCD) that uses amorphous silicon TFT as a switching device. This model is composed of a TFT LCD panel and a driving circuit. This TFT LCD has a 10.1(10:16) inch diagonally measured active display area with (800horizontal by1280 vertical pixel) resolution.

1.2. Features

- 10.1 (10:16 diagonal) inch configuration
- MIPI interface
- 16.7M color
- RoHS Compliance
- Halogen Free

1.3. General information

Item	Specification	Unit
Outline Dimension	143 (H) x 228.6 (V) x2.6(D)	mm
Display area	135.36(H) x 216.58 (V)	mm
Number of Pixel	800 RGB (H) x1280 (V)	pixels
Pixel pitch	0.13455(H) x 0.13455(V)s	mm
Pixel arrangement	RGB Vertical stripe	
Display mode	Normally Black	
Color Filter Array	RGB vertical stripes	
Backlight	27 White LED	
Interface	MIPI	
Luminous (Without PET)	500 (TYP)	cd/m2
Weight	TBD	g

2.0 Absolute Maximum Ratings

2.1 Electrical Absolute Rating

Item	Symbol	Min.	Max.	Unit	Note
Power Supply voltage	VDDIN	-0.3	3.6	V	GND=0
	AVDD	-0.3	6.0		
	AVEE	0	-6.0		

2.2 Environment Absolute Rating

Item	Symbol	Min.	Max.	Unit	Note
Operating Temperature	Topa	-10	50	°C	
Storage Temperature	Tstg	-20	60	°C	

2.3 Back-light Unit:

PARAMETER	Sym.	Min.	Typ.	Max.	Unit	Test Condition	Note
LED Current	IF	–	200	–	mA	–	–
LED Voltage	VF	9	9.6	10.5	V	–	–
Life Time		–	15000	–	Hr.	$I \leq 200\text{mA}$	–
Brightness	Luminous	200	250	--	Nits		--
Color	White						

Note (1) Permanent damage may occur to the LCD module if beyond this specification. Functional operation should be restricted to the conditions described under normal operating conditions.

(2) $T_a = 25 \pm 2^\circ\text{C}$

(3) Test condition: LED Current 200mA

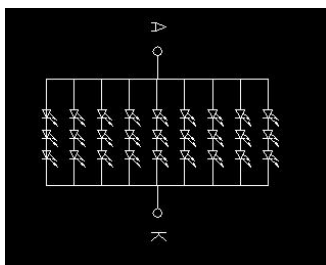

3.0 Optical Characteristics

3.1 Optical specification

Item	Symbol	Condition	Min.	Typ.	Max.	Unit	Note
Transmittance (With PZ)	T		—	4.8	—	%	
Contrast	CR		—	800	—		(1)(2)(4)
Response time	Tr+Tf			30	45	msec	(1)(3)
Color chromaticity (CIE1931)	Red		R_x	-	0.632		
		R_y		0.314			
	Green	G_x		0.267			
		G_y		0.547			
	Blue	B_x		0.142			
		B_y		0.102			
White	W_x		0.302				
	W_y		0.321				
Viewing angle	Hor.	θ_L	75	85	—		(1)(4)
		θ_R	75	85	—		
	Ver.	θ_U	75	85	—		
		θ_D	75	85	—		
View Direction	ALL						(5)

3.2 Measuring Condition

- Measuring surrounding : dark room
- Ambient temperature : 25±2℃
- 15min. warm-up time.

3.3 Measuring Equipment

- TOPCON BM-7
- Measuring spot size : field 2°

Note (1) Definition of Viewing Angle:

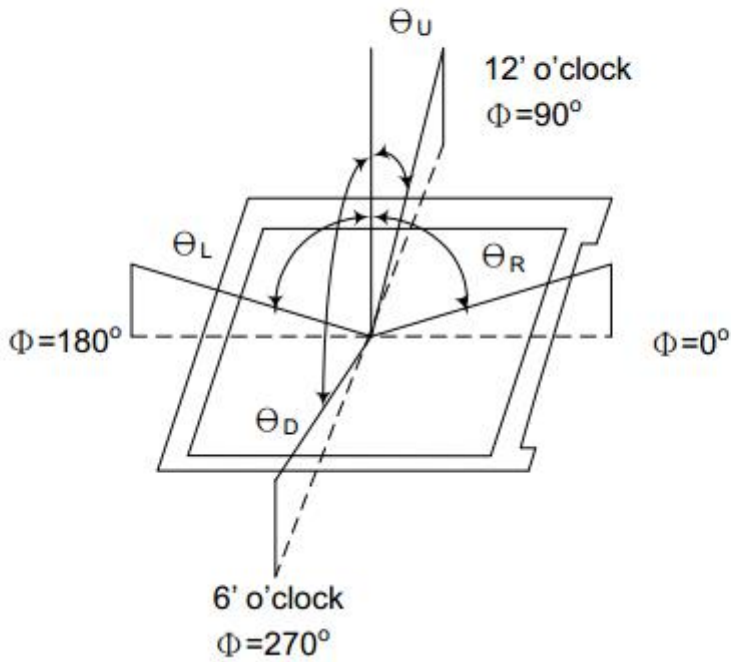

Note (2) Definition of Contrast Ratio (CR) :
measured at the center point of panel

$$CR = \frac{\text{Luminance with all pixels white}}{\text{Luminance with all pixels black}}$$

Note (3) Definition of Response Time : Sum of T_R and T_F

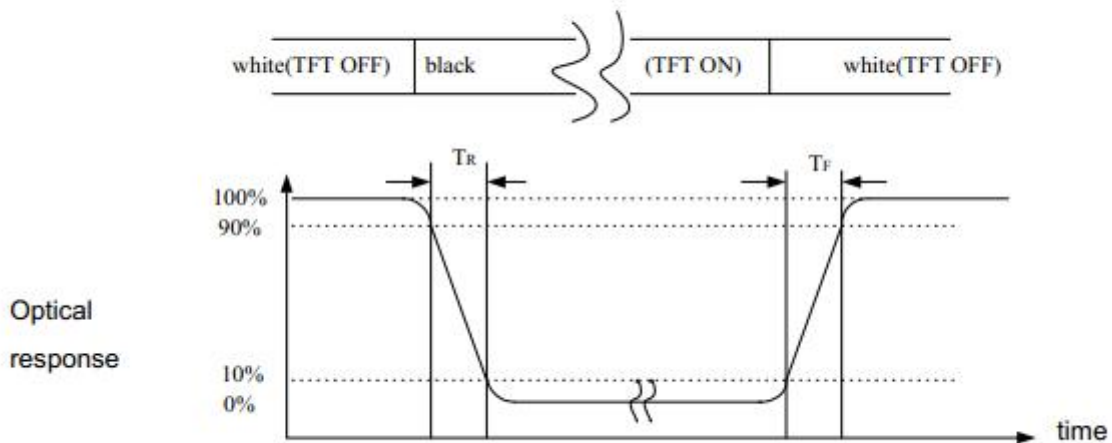

Note (4) Definition of optical measurement setup

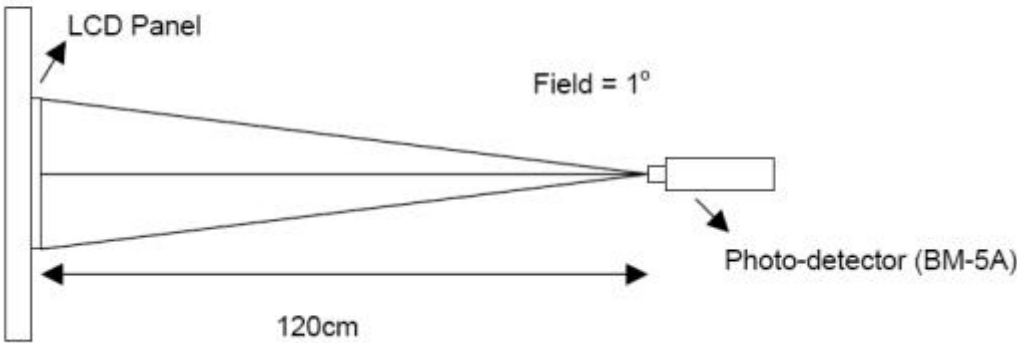

4.0 Pixel Format

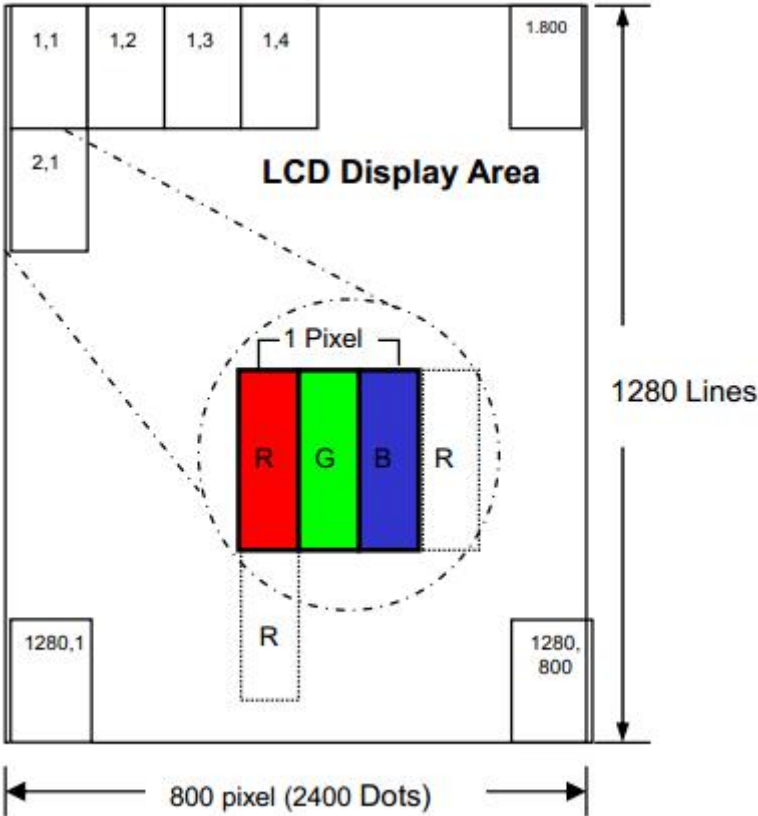

5.0 Interface Pin Connection

5.1 TFT LCD Module

PIN NO	SYMBOL	DESCRIPTION
1	LED+	Power supply for LED[Anode]
2	LED+	Power supply for LED[Anode]
3	LED+	Power supply for LED[Anode]
4	NC	NC
5	LED-	Power supply for LED[Cathode]
6	LED-	Power supply for LED[Cathode]
7	LED-	Power supply for LED[Cathode]
8	LED-	Power supply for LED[Cathode]
9	GND	Ground
10	GND	Ground
11	MIPI_2P	MIPI data positive signal(2P)
12	MIPI_2N	MIPI data negative signal(2N)
13	GND	Ground
14	MIPI_1P	MIPI data positive signal(1P)
15	MIPI_1N	MIPI data negative signal(1N)
16	GND	Ground
17	MIPI_CLKP	MIPI CLK positive signal(CLKP)
18	MIPI_CLKN	MIPI CLK positive signal(CLKN)
19	GND	Ground
20	MIPI_0P	MIPI data positive signal(0P)
21	MIPI_0N	MIPI data negative signal(0N)
22	GND	Ground
23	MIPI_3P	MIPI data positive signal(3P)
24	MIPI_3N	MIPI data negative signal(3N)
25	GND	Ground
26	VDDIO	Logic power 1.8V
27	RESET	Reset Pin
28	GND	Ground
29	VDDIO	Logic power 1.8V
30	VDD	Logic power 3.3V
31	VDD	Logic power 3.3V

5.01 ELECTRICAL CHARACTERISTICS

5.01.1TFT LCD Module

Item	Symbol	Min.	Typ.	Max.	Unit	Note
Supply Voltage	IOVCC	1.7	1.8	2.0	V	
	VCI	3.0	3.3	3.6	V	
Input signal voltage	V _{IH}	0.7DV _{DD}	-	DV _{DD}	V	
	V _{IL}	0	-	0.3DV _{DD}	V	
Power Current	I _{VDD3V3}	-	115	--	mA	

Note (1): GND=0V

5.02 DC Characteristics

5.02.1DC CHARACTERISTICS FOR DSI LP MODE

Parameter	Symbol	Conditions	Min.	Typ	Max.	Unit
LPDT Logic 1 contention threshold	V _{ILCD,MIN}	LP-CD	450	-	1600	mV
LPDT Logic 0 contention threshold	V _{IHCD,MAX}	LP-CD	0	-	200	mV
LPDT Logic 1 input threshold	V _{IH}	LP-RX (CLK, D0)	880	-	1600	mV
LPDT Logic 0 input threshold	V _{IL}	LP-RX (CLK, D0)	0	-	550	mV
LPDT Output high level	V _{OH}	LP-TX (D0)	1.1		1.3	V
LPDT Output low level	V _{OL}	LP-TX (D0)	-50		50	mV

Note (1) IOVCC=1.65~3.3V, VCC=2.6 to 3.8V, GND=0V, Ta=-30 to 70 °C

Note (2) Includes 50mV (-50mV to 50mV) ground difference.

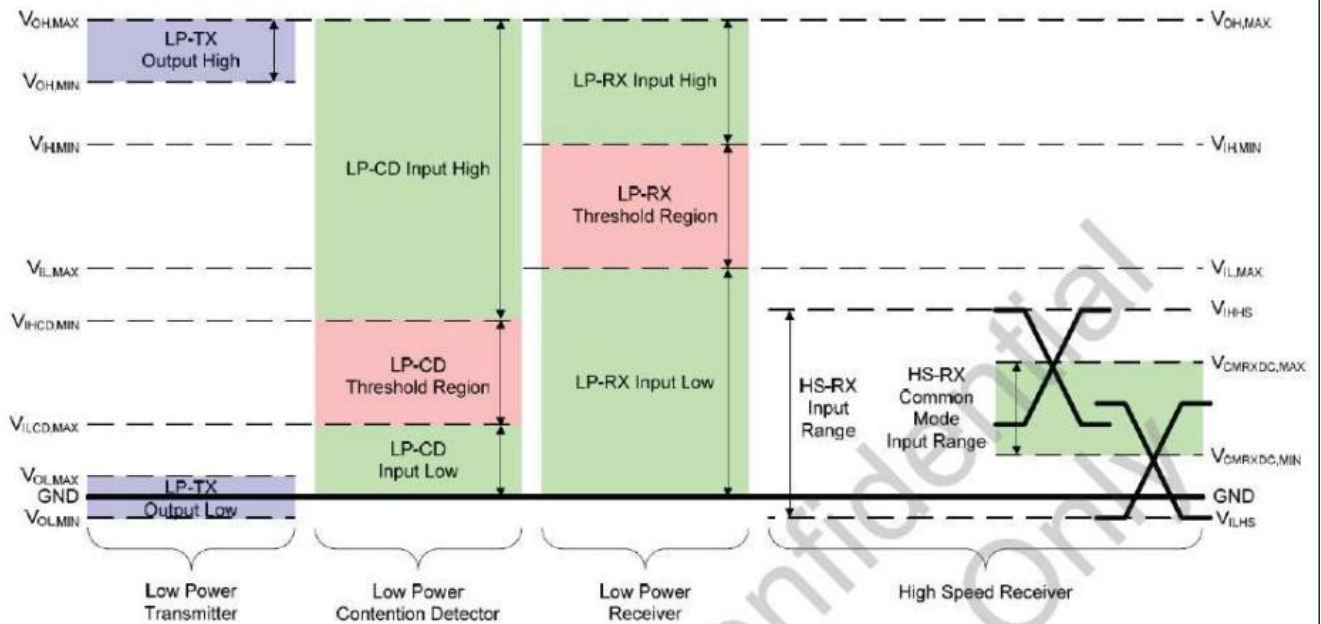

5.03DC CHARACTERISTICS FOR DSI HS MODE

Parameter	Symbol	Conditions	Min.	Typ	Max.	Unit
Common mode voltage	VCMRXDC	DSI-CLK+/-, DSI-D0+/-	70		330	mV
Hi-Speed transmit voltage	VOD	DSI-CLK+/-, DSI-D0+/-	140	200	250	mV
Single-ended input low voltage	VILHS	DSI-CLK+/-, DSI-D0+/-	-40	-	-	mV
Single-ended input high voltage	VIHHS	DSI-CLK+/-, DSI-D0+/-	-	-	460	mV
Differential input impedance	ZID	DSI-CLK+/-, DSI-D0+/-	80	100	125	Ω

Note (1) IOVCC=1.7~2.0V, VCC=3.0 to 3.8V, GND=0V, Ta=-30 to 70 °C

5.04 Interface Timing (MIPI DSI)

5.04.1 HIGH SPEED MODE

Signal	Symbol	Parameter	Min.	Typ.	Max.	Unit	Description
DSI-CLK+/-	$2xUI_{INST}$	Double UI instantaneous	4	-	25	ns	
DSI-CLK+/-	UI_{INSTA} UI_{INSTB}	UI instantaneous halves	2	-	12.5	ns	$UI = UI_{INSTA} = UI_{INSTB}$
DSI-Dn+/-	t_{DS}	Data to clock setup time	$0.15xUI$	-	-	ps	
DSI-Dn+/-	t_{DH}	Data to clock hold time	$0.15xUI$	-	-	ps	
DSI-CLK+/-	t_{DRTCLK}	Differential rise time for clock	150	-	$0.3xUI$	ps	
DSI-Dn+/-	$t_{DRTDATA}$	Differential rise time for data	150	-	$0.3xUI$	ps	
DSI-CLK+/-	t_{DFTCLK}	Differential fall time for clock	150	-	$0.3xUI$	ps	
DSI-Dn+/-	$t_{DFTDATA}$	Differential fall time for data	150	-	$0.3xUI$	ps	

Note: Dn = D0 and D1.

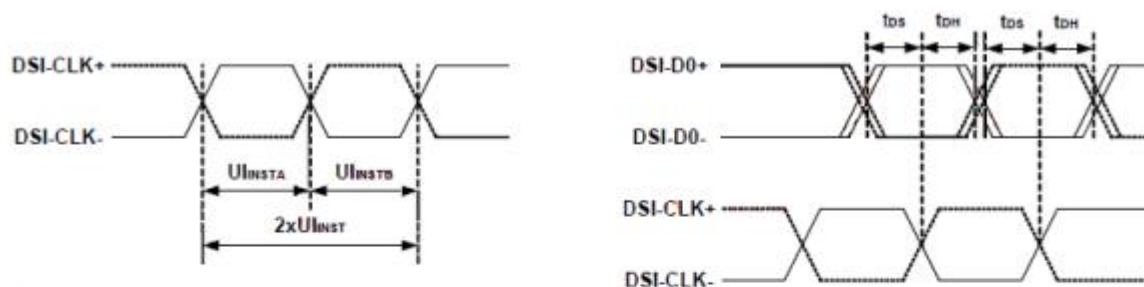

DSI clock channel timing

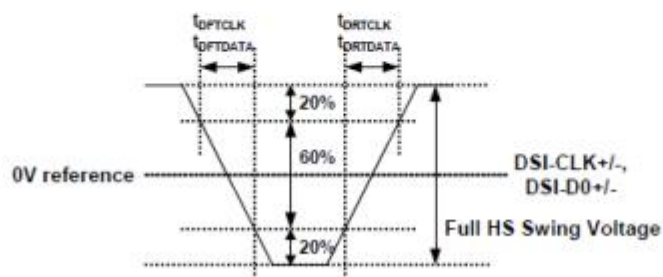

Rising and fall time on clock and data channel

5.04.2 LOW POWER MODE

Signal	Symbol	Parameter	Min.	Typ.	Max.	Unit	Description
DSI-D0+/-	T_{LPXM}	Length of LP-00, LP-01, LP-10 or LP-11 periods MPU, Display Module	50	-	75	ns	Input
DSI-D0+/-	T_{LPXD}	Length of LP-00, LP-01, LP-10 or LP-11 periods Display Module, MPU	58	-	75	ns	Output
DSI-D0+/-	$T_{TA-SURED}$	Time-out before the MPU start driving	T_{LPXD}	-	$2 \times T_{LPXD}$	ns	Output
DSI-D0+/-	$T_{TA-GETD}$	Time to drive LP-00 by display module	$5 \times T_{LPXD}$	-	-	ns	Input
DSI-D0+/-	T_{TA-GOD}	Time to drive LP-00 after turnaround request - MPU	$4 \times T_{LPXD}$	-	-	ns	Output

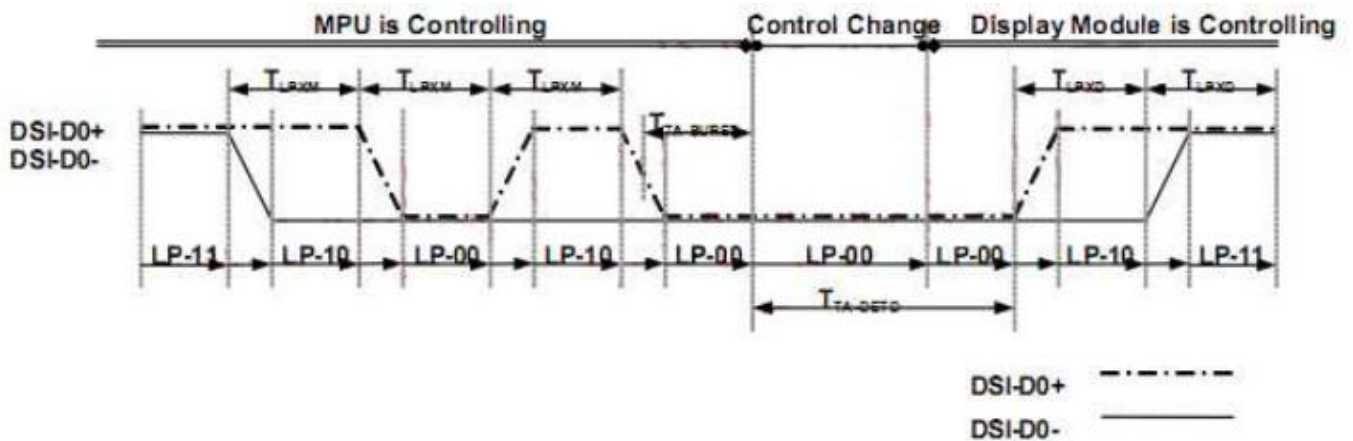

Bus Turnaround (BAT) from MPU to display module Timing

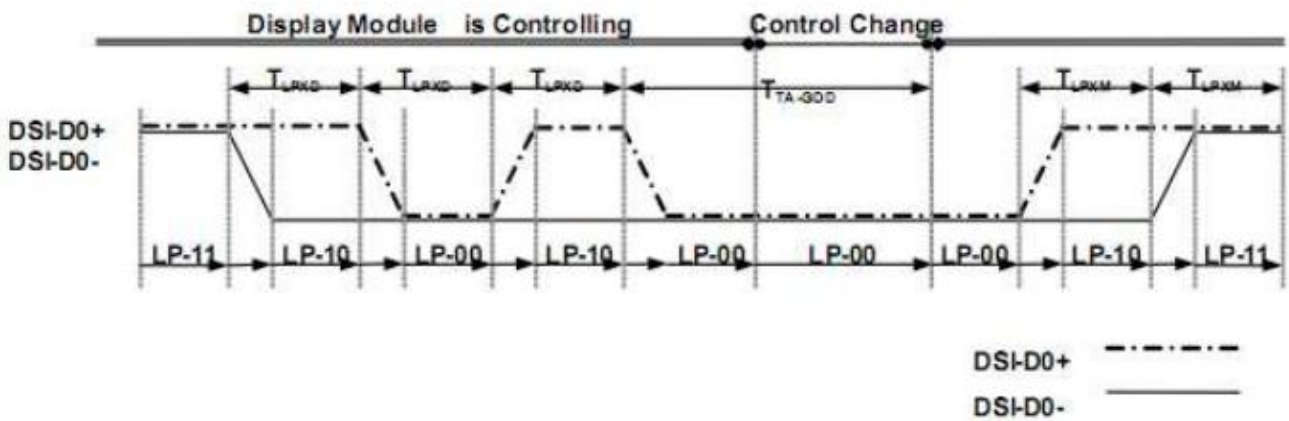

Bus Turnaround (BAT) from display module to MPU Timing

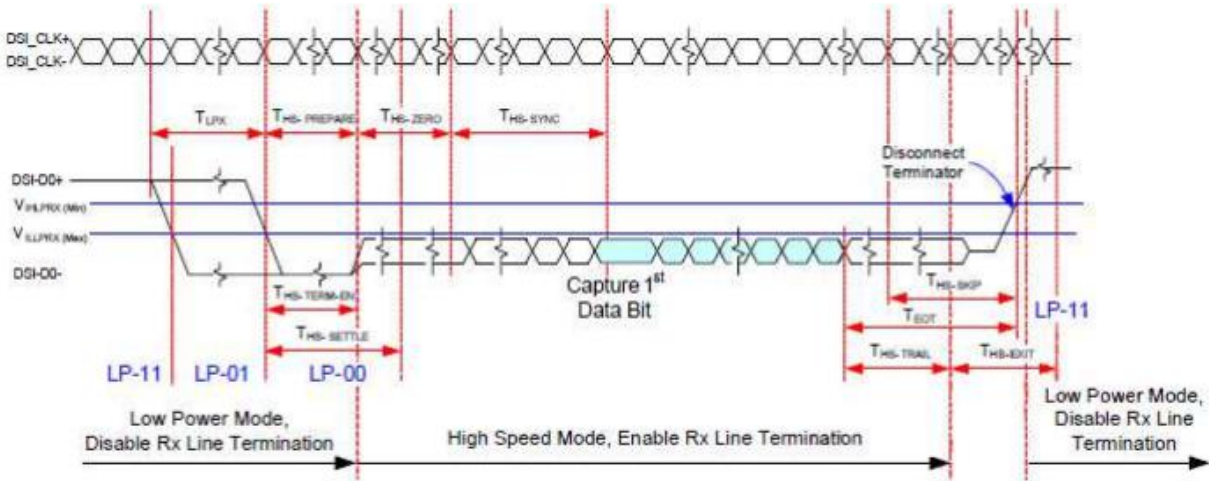

Fig. 7.6.8 Data lanes-Low Power Mode to/from High Speed Mode Timing

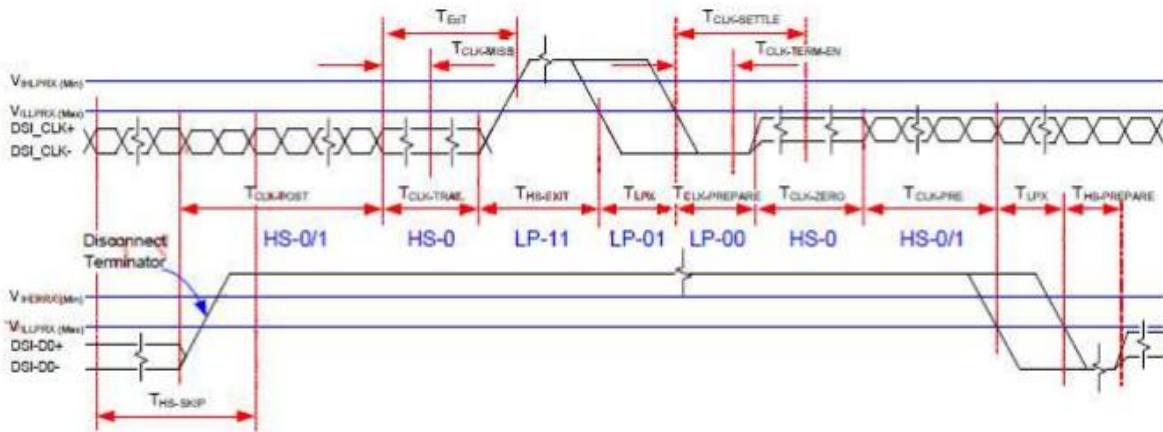

Fig. 7.6.9 Clock lanes- High Speed Mode to/from Low Power Mode Timing

6.0 Reliability test items

NO	Item	Conditions	Remark
1	High Temperature Storage	Ta=+60°C,48hrs	
2	Low Temperature Storage	Ta=-20°C,48hrs	
3	High Temperature Operation	Ta=+50°C,48hrs	
4	Low Temperature Operation	Ta=-10°C,48hrs	
5	High Temperature and High Humidity (operation)	Ta=+40°C,90%RH,96hrs	
6	Thermal Cycling Test (non operation)	-20°C(0.5hr)→+60°C(30min),100cycles	

Note: (1) All tests above are practiced at module type.

(2) There is no display function NG issue occurred, All the cosmetic specification is judged before the reliability stress.

8.0 Packing form

8.1 Packing form 1

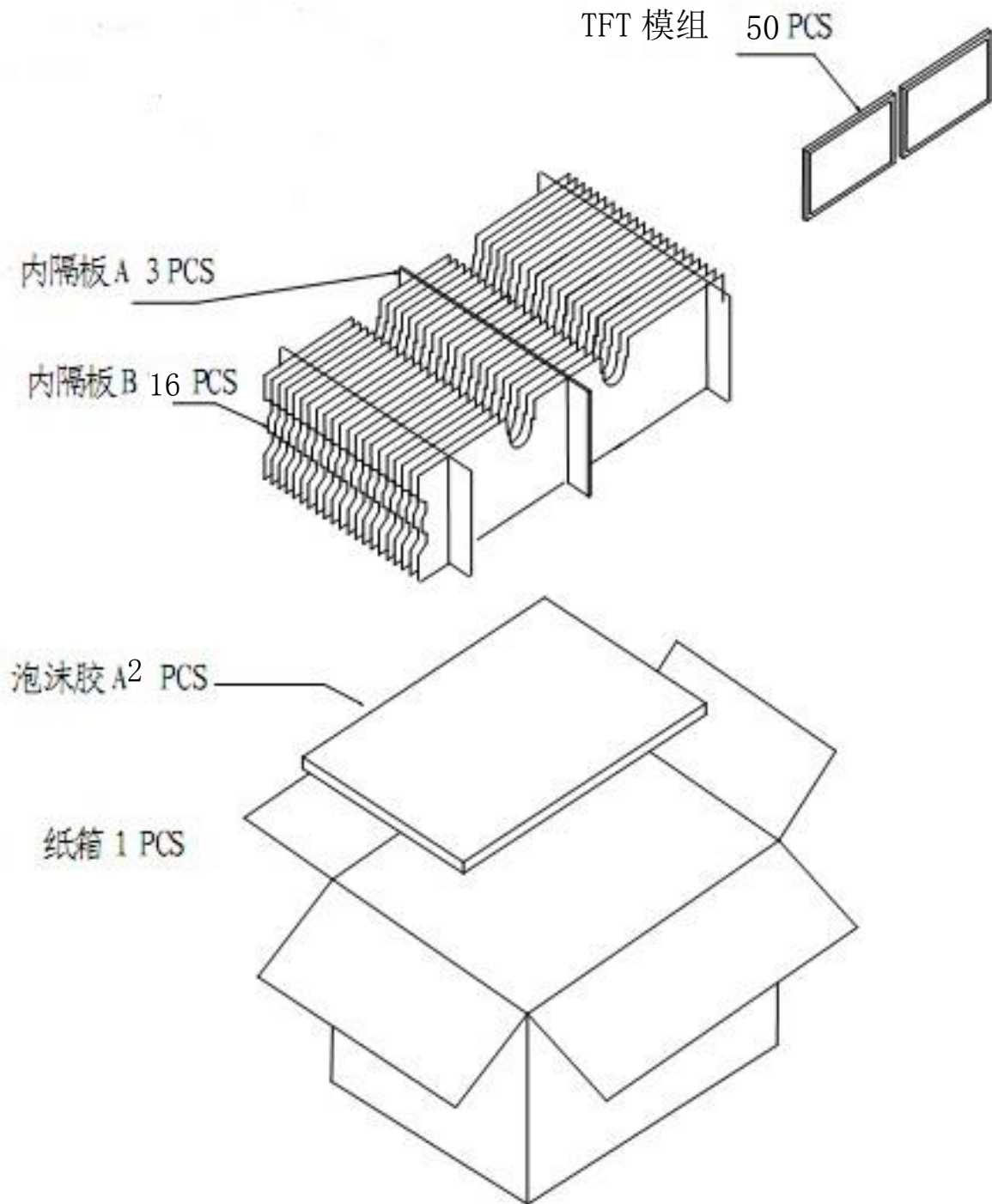

9.0 GENERAL PRECAUTION

9.1 Use Restriction

This product is not authorized for use in life supporting systems, aircraft navigation control systems, military systems and any other application where performance failure could be life threatening or otherwise catastrophic.

9.2 Disassembling or Modification

Do not disassemble or modify the module. It may damage sensitive parts inside LCD module, and may cause scratches or dust on the display. HannStar does not warrant the module, if customers disassemble or modify the module.

9.3 Breakage of LCD Panel

9.3.1. If LCD panel is broken and liquid crystal spills out, do not ingest or inhale liquid crystal, and do not contact liquid crystal with skin.

9.3.2. If liquid crystal contacts mouth or eyes, rinse out with water immediately.

9.3.3. If liquid crystal contacts skin or cloths, wash it off immediately with alcohol and rinse thoroughly with water.

9.3.4. Handle carefully with chips of glass that may cause injury, when the glass is broken.

9.4 Electric Shock

9.4.1. Disconnect power supply before handling LCD module.

9.4.2. Do not pull or fold the LED cable.

9.4.3. Do not touch the parts inside LCD modules and the fluorescent LED's connector or cables in order to prevent electric shock.

9.5 Absolute Maximum Ratings and Power Protection Circuit

9.5.1. Do not exceed the absolute maximum rating values, such as the supply voltage variation, input voltage variation, variation in parts' parameters, environmental temperature, etc., otherwise LCD module may be damaged.

9.5.2. Please do not leave LCD module in the environment of high humidity and high temperature for a long time.

11.5.3. It's recommended to employ protection circuit for power supply.

9.6 Operation

9.6.1 Do not touch, push or rub the polarizer with anything harder than HB pencil lead.

9.6.2 Use fingerstalls of soft gloves in order to keep clean display quality, when persons handle the LCD module for incoming inspection or assembly.

9.6.3 When the surface is dusty, please wipe gently with absorbent cotton or other soft material.

9.6.4 Wipe off saliva or water drops as soon as possible. If saliva or water drops contact with polarizer for a long time, they may causes deformation or color fading.

9.6.5 When cleaning the adhesives, please use absorbent cotton wetted with a little petroleum benzine or other adequate solvent.

9.7 Mechanism

Please mount LCD module by using mouting holes arranged in four corners tightly.

9.8 Static Electricity

9.8.1 Protection film must remove very slowly from the surface of LCD module to prevent from electrostatic occurrence.

9.8.2. Because LCD module use CMOS-IC on circuit board and TFT-LCD panel, it is very weak to electrostatic discharge. Please be careful with electrostatic discharge. Persons who handle the module should

be grounded through adequate methods.

9.9 Strong Light Exposure

The module shall not be exposed under strong light such as direct sunlight. Otherwise, display characteristics may be changed.

9.10 Disposal

When disposing LCD module, obey the local environmental regulations.