

LCD MODULE SPECIFICATION

Model Name: 1.22"LCM
SPEC.NO: XH012BSTE-1908V2
Date: 2019/12/04
Version: 1.0

- Preliminary Specification
- Final Specification

For Customer's Acceptance

Approved by	Comment

Approved by	Reviewed by	Prepared by

Contents

1. General Specifications	1
2. Block Diagram	2
3. Pin Assignments	3
4. Electrical Specifications	4
4.1. Backlight Unit	4
4.2. Absolute Maximum Rating	4
4.3. DC Characteristics	5
5. Optical Specifications	6
6. Timing Characteristic	11
7. Reliability Test Items	13
8. Inspection standrads	14
9. Mechanical Drawing	15



1. General Specifications

1.1. Description

The XH012BSTE-1908V2 is a color active matrix Thin Film Transistor (TFT) Liquid Crystal Display (LCD) that uses amorphous silicon (a-Si) TFT as a switching device. This module is composed of a single 1.22 inches transmissive type main TFT-LCD Panel and a resistive touch screen display. The resolution of the panel is 240 x204 pixels and can display 65K color.

1.2. Features

- TM type for main TFT-LCD panel
- One backlight with 2 white LED
- 80-system 3Line serial bus
- Full, Still, Partial, Sleep & Standby mode are available

1.3. Application

- Display terminals for cellular phone

1.4. General Specification

No.	Item	Specification	Unit	Remark
1	LCD Size	1.22	inch	-
2	Panel Type	a-si TFT	-	-
3	Touch Panel Type	TBD	-	-
4	Resolution	240x(RGB)x204	pixel	-
5	Display Mode	Normally balck, Transmissive	-	-
6	Display Number of Colors	65K	-	-
7	Viewing Direction	all	-	Note 1
8	Contrast Ratio	900	-	-
9	Luminance	320	cd/m ²	Note 2
10	Module Size	33.66(W)x33.02(L)x1.50(T)	mm	Note 1
11	Panel Active Area	30.96(W)x26.32(V)	mm	Note 1
12	Touch Panel Active Area	-	mm	-
13	Touch Panel View Area	-	mm	-
14	Pixel Pitch	0.129*0.129	mm	-
15	Weight	TBD	g	-
16	Driver IC	ST7789V2-G4	-	-
17	Driver IC RAM Size	TBD	bit	-
18	Light Source	2 White LEDs in Seriesl	-	-
19	Interface	SPI 3Line	-	-
20	Module power consumption	-	mw	-
21	Operating Temperature	-20~70	°C	-
22	Storage Temperature	-30~80	°C	-

Note 1: Please refer to the mechanical drawing.

Note 2: Luminance is measured with touch panel attached.

2. Block Diagram

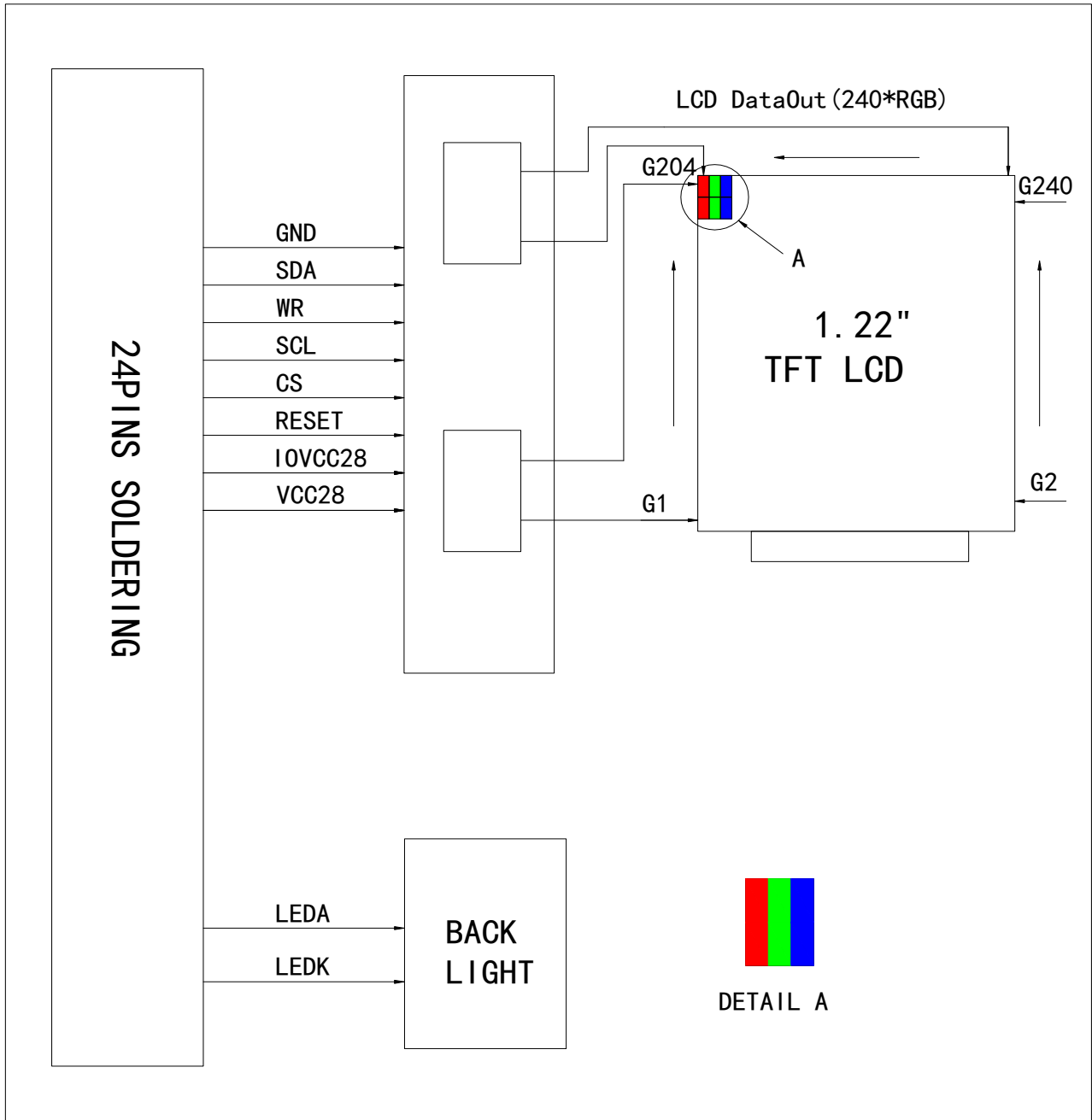

3. Pin Assignments

Pin No.	Symbol	I/O	Function	Remark
1	LEDK	P	B/L LED Cathode	
2	LEDK	P	B/L LED Cathode	
3	GND	P	Ground	
4	GND	P	Ground	
5	FMARK	O	No connect	-
6	SDA	I/O	Serial input/output data	
7	WR	-	No connect	
8	SCL	I	Serial interface clock	
9	CS	I	Chip select signal (Low:active)	
10	RESET	I	Reset signal (Low: active)Register select	
11	IOVCC18	P	Power Supply for I/O system.IOVCC=2.4V ~ 3.3V	-
12	IOVCC18	P	Power Supply for I/O system.IOVCC=2.4V ~ 3.3V	
13	VCC28	P	VCI Power supply Power Supply for Analog,VCC=2.4V~3.3V	
14	VCC28	P	VCI Power supply Power Supply for Analog,VCC=2.4V~3.3V	
15	GND	P	Ground	
16	GND	P	Ground	
17-22	NC	-	No connect	
23	LEDA	P	B/L LED Anode	-
24	LEDA	P	B/L LED Anode	

4. Electrical Specifications

4.1. Backlight Unit

The backlight system is an edge lighting type with 2 white LEDs.



(T_a=+25°C)

Item	Symbol	Values			Unit	Remark
		Min.	Typ.	Max.		
Current	I _f	-	20	-	mA	Note 1
Voltage	V _f		6.4		V	I _f =20mA
Uniformity	Avg	80			%	I _f =20mA
Power Consumption	P _{BL}	-	128	-	mW	Note 2

Note1: 2 LEDs are connected in Series; each LED's current consumption is 20mA.

Note2: Where I_B= 20 mA, P_{BL} = I_B x V_{BL}, V_{BL} is backlight forward voltage.

4.2. Absolute Maximum Rating

Item	Symbol	Rating	Unit
Supply Voltage	VDD	- 0.3 ~ +4.6	V
Supply Voltage (Logic)	VDDI	- 0.3 ~ +4.6	V
Driver Supply Voltage	VGH-VGL	-0.3 ~ +30.0	V
Logic Input Voltage Range	VIN	-0.3 ~ VDDI + 0.5	V
Logic Output Voltage Range	VO	-0.3 ~ VDDI + 0.5	V
Operating Temperature Range	TOPR	-30 ~ +85	°C
Storage Temperature Range	TSTG	-40 ~ +125	°C

Table 1 Absolute Operation Range

Note: If one of the above items is exceeded its maximum limitation momentarily, the quality of the product may be degraded.

Absolute maximum limitation, therefore, specify the values exceeding which the product may be physically damaged. Be sure to use the product within the recommend range.

4.3. DC Characteristics

Parameter	Symbol	Condition	Specification			Unit	Related Pins
			MIN.	TYP.	MAX.		
Power & Operation Voltage							
System Voltage	VDD	Operating voltage	2.4	2.75	3.3	V	
Interface Operation Voltage	VDDI	I/O Supply Voltage	1.65	1.8	3.3	V	
Gate Driver High Voltage	VGH		12.2		14.97	V	Note 4
Gate Driver Low Voltage	VGL		-12.5		-7.16	V	
Gate Driver Supply Voltage		VGH-VGL	19.36		27.47	V	Note 5
Input / Output							
Logic-High Input Voltage	VIH		0.7VDDI		VDDI	V	Note 1
Logic-Low Input Voltage	VIL		VSS		0.3VDDI	V	Note 1
Logic-High Output Voltage	VOH	IOH = -1.0mA	0.8VDDI		VDDI	V	Note 1
Logic-Low Output Voltage	VOL	IOL = +1.0mA	VSS		0.2VDDI	V	Note 1
Logic-High Input Current	IIH	VIN = VDDI			1	uA	Note 1
Logic-Low Input Current	IIL	VIN = VSS	-1			uA	Note 1
Input Leakage Current	IIL	IOH = -1.0mA	-0.1		+0.1	uA	Note 1
VCOM Voltage							
VCOM amplitude	VCOM			VSS		V	
Source Driver							
Source Output Range	Vsout		VAN		VAP	V	
Gamma Reference Voltage(Positive)	VAP		4.45		6.4	V	Note 6
Gamma Reference Voltage(Negative)	VAN		-4.6		-2.65	V	
Source Output Settling Time	Tr	Below with 99% precision			20	us	Note 2
Output Offset Voltage	VOFFSET				35	mV	Note 3

Table 2 Basic DC Characteristics

Notes:

1. TA= -30 to 70°C (to +85°C no damage).
2. Source channel loading= 2KΩ+12pF/channel, Gate channel loading=5KΩ+40pF/channel.
3. The Max. value is between measured point of source output and gamma setting value.
4. When evaluating the maximum and minimum of VGH, VDD=2.8V.

5. Optical Specifications

 ($T_a=+25^{\circ}\text{C}$, $V_{CI}=2.8\text{V}$, $V_{DD}=1.8\text{V}$, $I_B=60\text{mA}$)

Item	Symbol	Condition	Values			Unit	Remark
			Min.	Typ.	Max.		
Viewing Angle Range	Left	θ_L	$CR \geq 10$	80	-	degree	Note 1,2
	Right	θ_R		80	-		
	Top	θ_T		80	-		
	Bottom	θ_B		80	-		
Response Time	$T_{on} + T_{off}$	Normal $\theta = \phi = 0^{\circ}$	-	30	35	ms	Note 2,3
Contrast Ratio	CR	Normal $\theta = \phi = 0^{\circ}$		900	-	-	Note 2,4
Luminance	L	Normal $\theta = \phi = 0^{\circ}$		320	-	cd/m ²	Note 2,5
Flicker	-	-	No Visible			-	Note 8
Crosstalk	-	-	No Visible			-	Note 9
Color Chromaticity (CIE1931)	White	W_x	Normal $\theta = \phi = 0^{\circ}$	TBD		-	Note 2,6
		W_y		TBD			
	Red	R_x		TBD			
		R_y		TBD			
	Green	G_x		TBD			
		G_y		TBD			
	Blue	B_x		TBD			
		B_y		TBD			
Color Gamut	NTSC	CIE1931		50	-	%	-

Note 1: Definition of viewing angle range

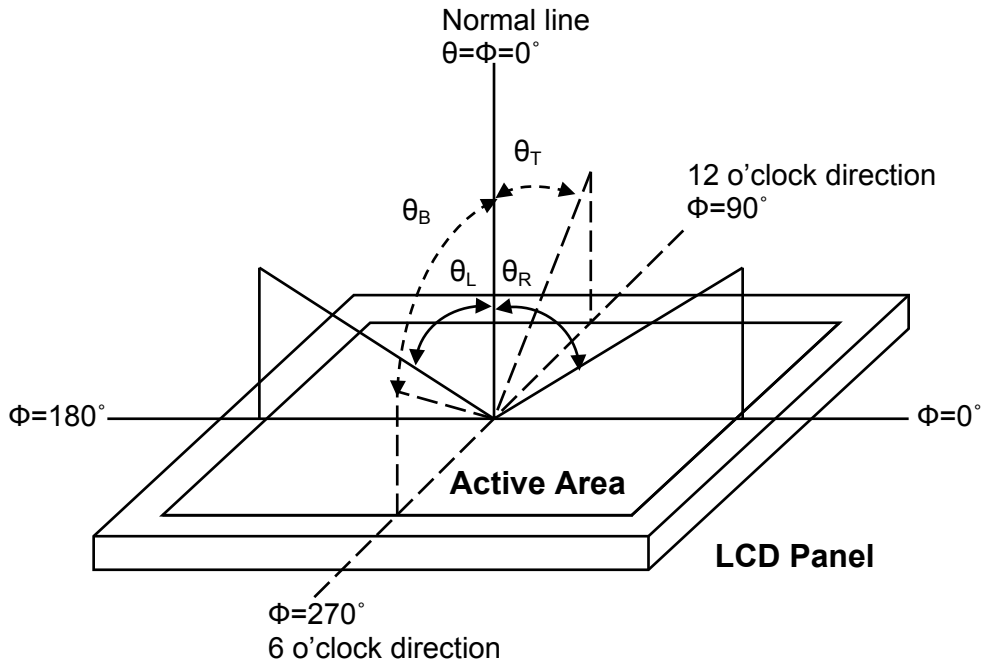

Fig. 1 Definition of viewing angle

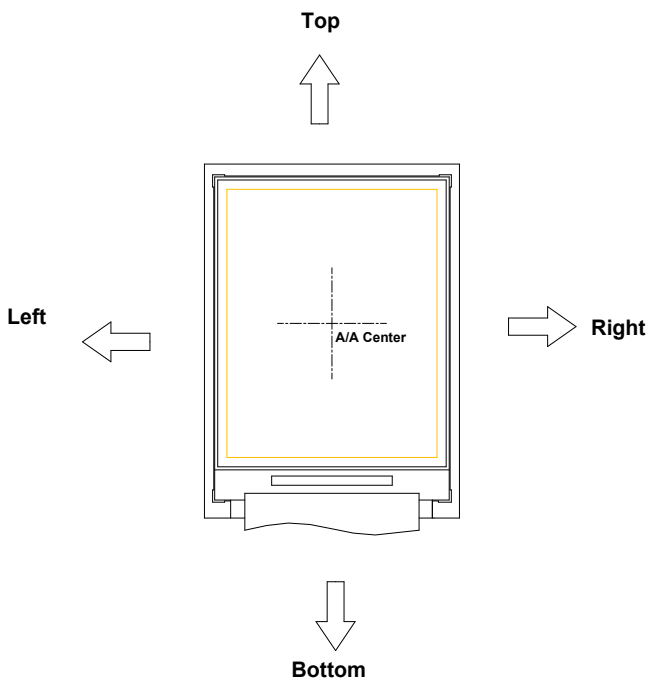

Fig. 2 Definition of viewing angle for display

Note 2: Definition of optical measurement system

The optical characteristics should be measured in a dark room with ambient temperature $T_a=+25$. The optical properties are measured at the center point of the LCD screen after 5 minutes operation. (Equipment: Photo detector TOPCON BM-5A or BM-7 /Field of view: 1° /Height: 500mm.)

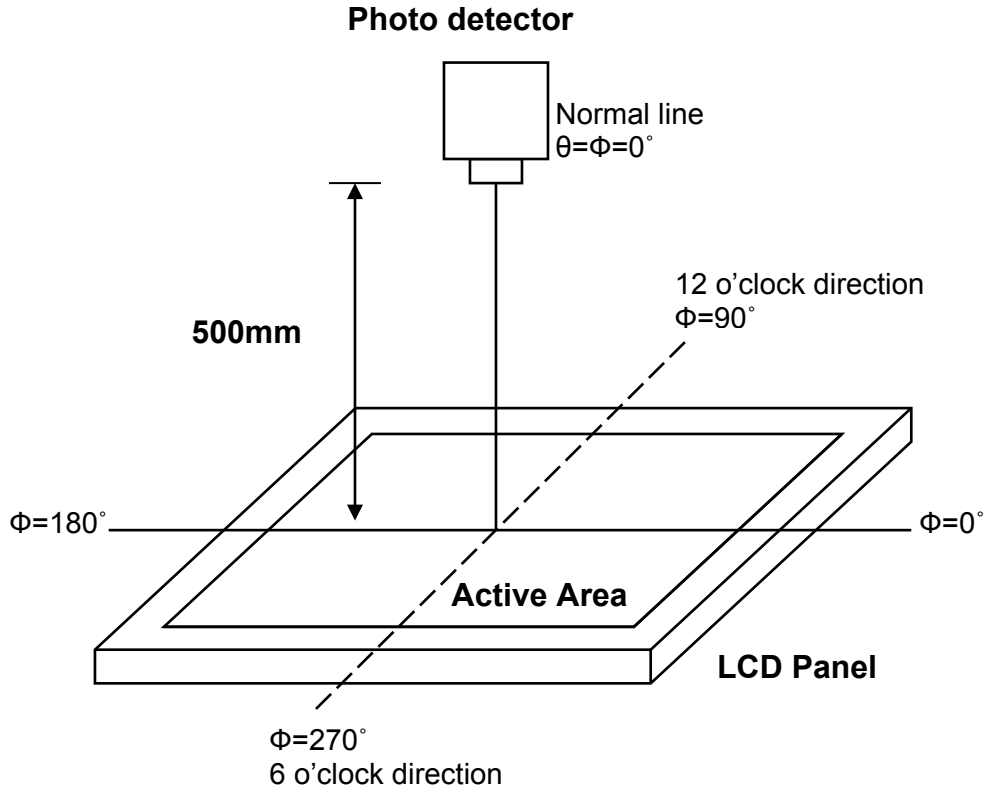

Fig. 3 Optical measurement system setup

Note 3: Definition of response time

The response time is defined as the LCD optical switching time interval between "White" state and "Black" state. Rise time (T_{on}) is the time between photo detector output intensity changed from 90% to 10%, and fall time (T_{off}) is the time between photo detector output intensity changed from 10% to 90%.

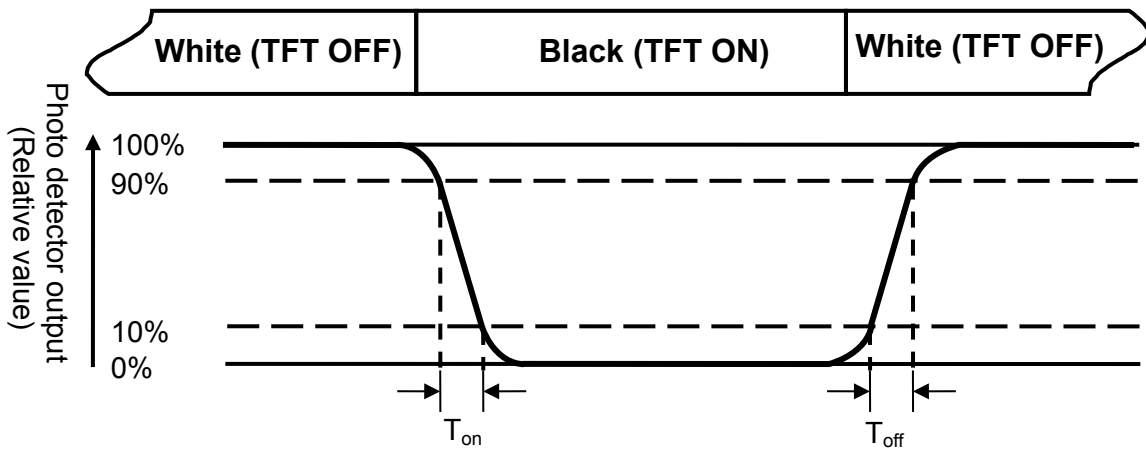

Fig. 4 Definition of response time

Note 4: Definition of contrast ratio

$$\text{Contrast ratio (CR)} = \frac{\text{Luminance measured when LCD on the "White" state}}{\text{Luminance measured when LCD on the "Black" state}}$$

Note 5: Definition of luminance

Measured at the center area of the panel when LCD panel is driven at "white" state.

Note 6: Definition of color chromaticity (CIE1931)

Color coordinates measured at the center point of LCD when panel is driven at "White", "Red", "Green" and "Blue" state respectively.

Note 7: Definition of luminance uniformity

To test for uniformity, the tested area is divided into 3 rows and 3 columns. The measurement spot is placed at the center of each circle as below.

$$\text{Luminance Uniformity (U}_L\text{)} = \frac{L_{\min}}{L_{\max}}$$

L-----Active area length W----- Active area width

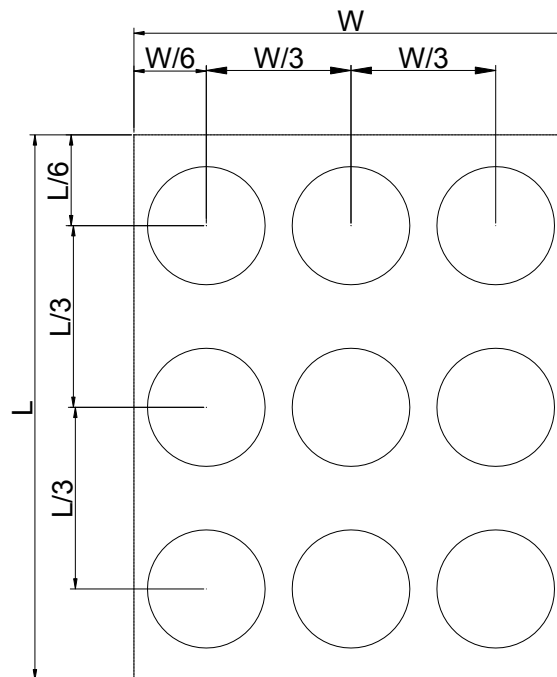

Fig. 5 Definition of luminance uniformity

L_{\max} : The measured maximum luminance of all measurement position.

L_{\min} : The measured minimum luminance of all measurement position.

Note 8: Definition of Flicker

Flicker is the pattern usually used to describe the visual sensation produced by a rapidly varying light intensity. There should be no visible flicker in normal direction of the display when the following figure are loaded.

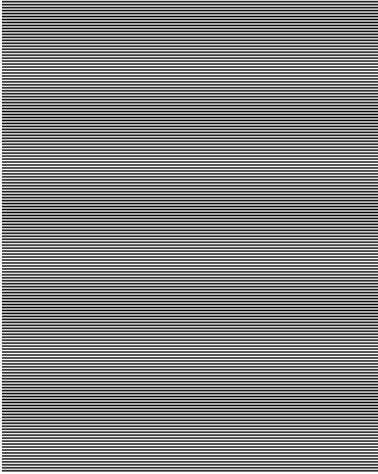

Fig.6 Flicker checker pattern

Note9: Definition of crosstalk

There should be no visible in normal direction of the display when the following figures are loaded.

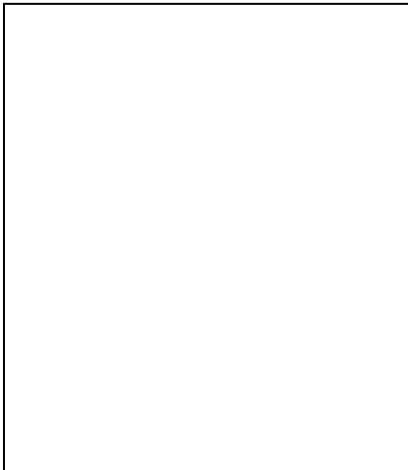

Fig.7 Crosstalk checker pattern

6. Timing Characteristic

6.1. AC Characteristics

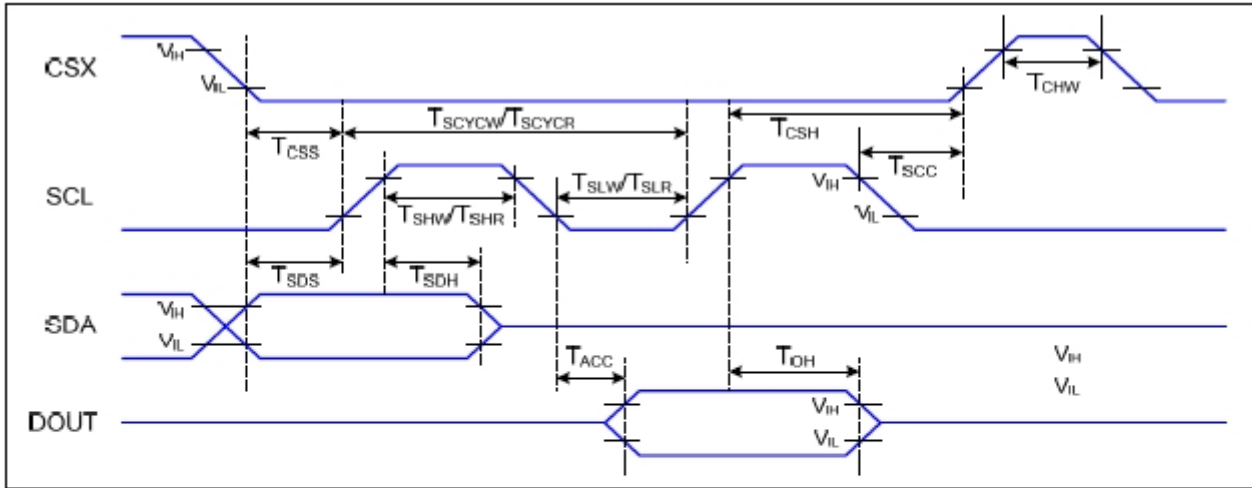

Figure 4 3-line serial Interface Timing Characteristics

VDDI=1.65 to 3.3V, VDD=2.4 to 3.3V, AGND=DGND=0V, Ta=-30 to 70 °C

Signal	Symbol	Parameter	Min	Max	Unit	Description
CSX	T_{CSS}	Chip select setup time (write)	15		ns	
	T_{CSH}	Chip select hold time (write)	15		ns	
	T_{CSS}	Chip select setup time (read)	60		ns	
	T_{SCC}	Chip select hold time (read)	65		ns	
	T_{CHW}	Chip select "H" pulse width	40		ns	
SCL	T_{SCYCW}	Serial clock cycle (Write)	66		ns	
	T_{SHW}	SCL "H" pulse width (Write)	15		ns	
	T_{SLW}	SCL "L" pulse width (Write)	15		ns	
	T_{SCYCR}	Serial clock cycle (Read)	150		ns	
	T_{SHR}	SCL "H" pulse width (Read)	60		ns	
	T_{SLR}	SCL "L" pulse width (Read)	60		ns	
SDA (DIN)	T_{SDS}	Data setup time	10		ns	
	T_{SDH}	Data hold time	10		ns	
DOUT	T_{ACC}	Access time	10	50	ns	For maximum CL=30pF
	T_{OH}	Output disable time	15	50	ns	For minimum CL=8pF

Table 5 3-line serial Interface Characteristics

Note : The rising time and falling time (T_r , T_f) of input signal are specified at 15 ns or less. Logic high and low levels are specified as 30% and 70% of VDDI for input signals.

6.2. Reset timing

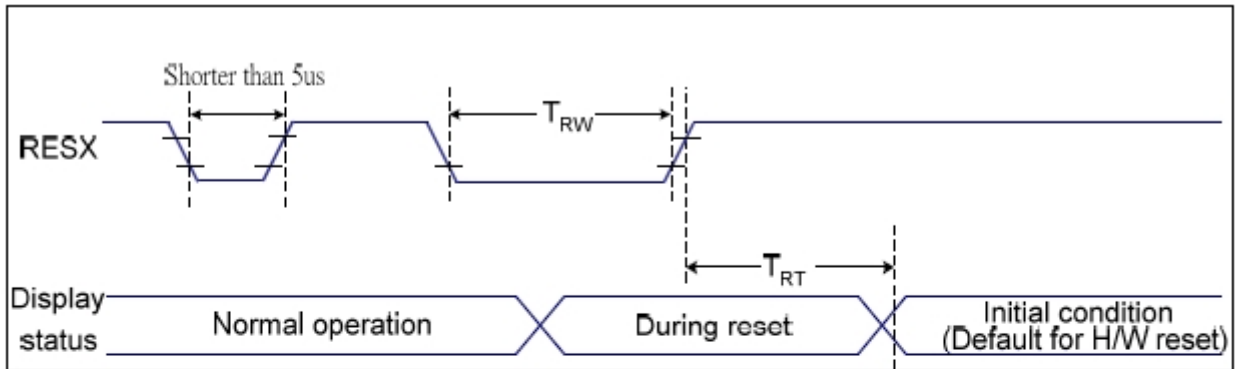

Figure 7 Reset Timing

$V_{DDI}=1.65$ to $3.3V$, $V_{DD}=2.4$ to $3.3V$, $AGND=DGND=0V$, $T_a=-30 \sim 70 \text{ } ^\circ\text{C}$

Related Pins	Symbol	Parameter	MIN	MAX	Unit
RESX	TRW	Reset pulse duration	10	-	us
	TRT	Reset cancel	-	5 (Note 1, 5)	ms
				120 (Note 1, 6, 7)	ms

Table 8 Reset Timing

7. Reliability Test Items

Test Items	Test Conditions	Remark
High Temperature Storage	+80°C±3°C for 200 hours	-
Low Temperature Storage	-30°C±3°C for 200 hours	-
High Temperature Operation	+70°C±3°C for 120 hours	-
Low Temperature Operation	-20°C±3°C for 120 hours	-
High Temperature and Humidity Operation	+40°C±3°C, 90%±3%RH max. for 120 hours	-
Thermal Shock	-30°C/0.5h ~ +80°C/0.5h for a total 100 cycles, Start with cold temp and end with high temp	-
Vibration Test	Frequency range:10~55Hz Stoke:1.5mm Sweep:10Hz~55Hz~10Hz 2 hours for each direction of X. Y. Z. (6 hours for total)	-
Mechanical Shock	100G 6ms,±X, ±Y, ±Z 3 times for each direction	-
Package Vibration Test	Random Vibration : 0.015G ² /Hz from 5-200Hz, -6dB/Octave from 200-500Hz 1 hour for each direction of X. Y. Z. (3 hours for total)	-
Package Drop Test	Height :76cm(Weight≤10kg); 60cm(Weight>10kg) 1 corner, 3 edges, 6 surfaces	-
Electro Static Discharge	± 2KV, Human Body Mode, 100pF/1500Ω	-

Note1: During the display practical test under normal operation condition, there shall be no change, which may affect display function.

Note2: Before functional check, the test sample requires a 2 hours storage time at room temperature.

8. Inspection standards

8.1 Major Defect

Item NO	Items to be inspected	Inspection Standard	Classification of defects
8.1.1	All functional defects	1) No display 2) Display abnormally 3) Missing vertical , horizontal segment 4) Short circuit 5) Back-light no lighting, flickering and abnormal lighting. 6) No reaction when touching it	Major
8.1.2	Missing	Missing component	
8.1.3	Outline dimension	Overall outline dimension beyond the drawing is not allowed.	

8.2 Cosmetic Defect

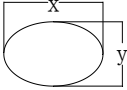
Item NO	Items to be inspected	Inspection Standard	Classification of defects
<p>For dark/white spot, size Φ is defined y as $\Phi = (x+y)/2$</p> 			
CTP Clear Spots Black and white Spot Stain Inclusion saw edge pin holes	$\Phi \leq 0.1$	Ignore	In CTP AA Zone
	$0.10 < \Phi \leq 0.20$	Acceptable 8pcs	
	$0.20 < \Phi \leq 0.30$	Acceptable 6pcs	
	$0.30 < \Phi$	0	
LCD Clear Spots Black and white Spot defect Pinhole, Foreign Particle, Dirt under polarizer	$\Phi \leq 0.1$	Ignore	In LCD AA Zone
	$0.10 < \Phi \leq 0.20$	Acceptable 3pcs	
	$0.20 < \Phi \leq 0.30$	Acceptable 2pcs	
	$0.30 < \Phi$	0	

9. Mechanical Drawing

