



东莞市科傲光电有限公司

DONG GUAN KAO ELECTRONICS CO., LTD

文件编号

KAO-101BC-HD01

SPECIFICATION FOR LCD MODULE

第 1 页, 共 13 页



CERT. No. QAC0946535  
(ISO9001)



CERT. No. HKG002005  
(ISO14001)

# SPECIFICATION FOR LCD MODULE

客户名称 (CUSTOMER NAME) : \_\_\_\_\_

客户代码 (CUSTOMER CODE) : \_\_\_\_\_

产品名称 (DESCRIPTION) : 10.1 寸 IPS LCM

产品编号 (PRODUCT CODE) : KAO-101BC-HD01

# CONFIDENTIAL

Dongguan Keao Photoelectric Co., Ltd. (科傲确认)

核准	审核	制作
APPROVED BY	CHECKED BY	PREPARED BY
		ZhangwenTong

Customer	Comfirm	(客户确认)
核准	审核	确认
APPROVED BY	CHECKED BY	CONFIRM BY

电话 Tel: +86-769-39028875

地址: 广东省东莞市塘厦镇田心恒盛隆工业区 B 栋二楼

网址: [www.keao-lcd.cn](http://www.keao-lcd.cn)





## 目录 Contents

▼1、GENERAL DESCRIPTIONG

▼2、GENERAL FEATURES

▼3、ABSOLUTE MAXIMUM RATINGS

▼4、Typical Operation Conditions

▼5、OPTICAL SPECIFICATIONS

▼6、Reliability Test Items

▼7、PIN DESCRIPTION

▼8、OUTLINE DIMENSION



## 1. General Description

The KAO-101BC-HD01 model is a Color TFT LCD supplied by KEAO Co.,LTD. This main Module has a 10.1 inch diagonally measured active display area with 720(RGB)X1280 resolution. Each pixel is divided into Red, Green and Blue sub-pixels and dots which are arranged in vertical stripes. LCD color is determined with 262,000 colors signal for each pixel. The KAO-101BC-HD01 has been designed to apply the interface method that enables low power, high speed, and high contrast. The KAO-101BC-HD01 is intended to support applications where thin thickness, wide viewing angle and low power are critical factors and graphic displays are important.

## 2. General Features

Item	Display Panel	Remark
Display Mode	Normally black	
Viewing Direction	All O'CLOCK	
Input Signals	RGB	
Outside Dimensions	143mm(W)*235mm(H)*4.5mm(T)	
Effective Area	-	
Active Area	125.28mm(W)×222.72mm(H)	
Number of Pixels	720×RGB×1280Pixels	
Pixel Pitch	0.058mm(H) RGB×0.174mm(W)	
Pixel Arrangement	Digital	

## 3. Absolute Maximum Ratings

The following are maximum values which, if exceeded may cause operation or damage to the unit.

ITEM	Symbol	Min.	Typ.	Max.	Unit	Remark
Power voltage	DVDD	-0.3	--	6.6	V	
	AVDD	6.5	10	13.5	V	
	VGH	-0.3	18	40	V	
	VGL	-20	-12	-0.3	V	
	VGH-VGL	-	--	40	mA	
Operation Temperature	TOP	-20	--	70	°C	
Storage Temperature	TST	-30	-	80	°C	
LED Reverse Voltage	VR	--	-	1.2	%RH	Note 1
LED Forward Current	If	--	-	25	°C	Note2



Note 1: The absolute maximum rating values of this product are not allowed to be exceeded at any times. Should a module be used with any of the absolute maximum ratings exceeded, the characteristics of the module may not be recovered, or in an extreme case, the module may be permanently destroyed.

Note 2: VR Conditions: Zener Diode 20mA。

## 4. Typical Operation Conditions

### 4.1 Main Window Display

(Unless specified, the ambient temperature  $T_a=25^{\circ}\text{C}$ ) (Note 1)

Properties	Sym.	Min	Typ.	Max	Unit	Note
Power voltage	DVDD	3.0	3.3	3.6	V	Note 2
	AVDD	10.2	10.4	10.6	V	
	VGH	15.3	16.0	16.7	V	
	VGL	-7.7	-7.0	-6.3	V	
Input signal voltage	Vcom	-	TBD	-	V	
Input logic high voltage	VIH	0.7DVDD	-	DVDD	V	Note 3
Input logic low voltage	VIL	0	-	0.3VDD	V	

Note 1: Be sure to apply DVDD and VGL to the LCD first, and then apply VGH.

Note 2: DVDD setting should match the signals output voltage (refer to Note 3) of customer's system board.

Note 3: DCLK,HS,VS,RESET,U/D, L/R,DE,R0~R7,G0~G7,B0~B7,MODE,DITHB.

### 4.2 Current Consumption

Item	symbol	Values			Unit	Remark
		Min	Typ	Max		
Current for Driver	IGH	-	TBD	-	mA	VGH=17.0V
	IGL	-	TBD	-	mA	VGL=-5.0V
	IDVDD	-	TBD	-	mA	DVDD=3.3V
	IAVDD	-	TBD	-	mA	AVDD=10.4

### 4.3 Backlight Driving Conditions

Item	symbol	Values			Unit	Remark
		Min	Typ	Max		
Voltage for LED backlight	VL	16.8	18	-	V	Note 1
Current LED backlight	IL	38	20	-	mA	
LED life time	-	20000	-	-	Hr	Note 2
LCM Luminance	-	-	380		-	Cd/m <sup>2</sup>



Note 1: The LED Supply Voltage is defined by the number of LED at  $T_a=25^{\circ}\text{C}$  and  $L=80\text{mA}$ .

Note 2: The “LED life time” is defined as the module brightness decrease to 50% original brightness at  $T_a=25^{\circ}\text{C}$  and  $I_L=80\text{mA}$ . The LED lifetime could be decreased if operating  $I_L$  is larger than 80mA.

### 4.4 Power Sequence

#### Power on:

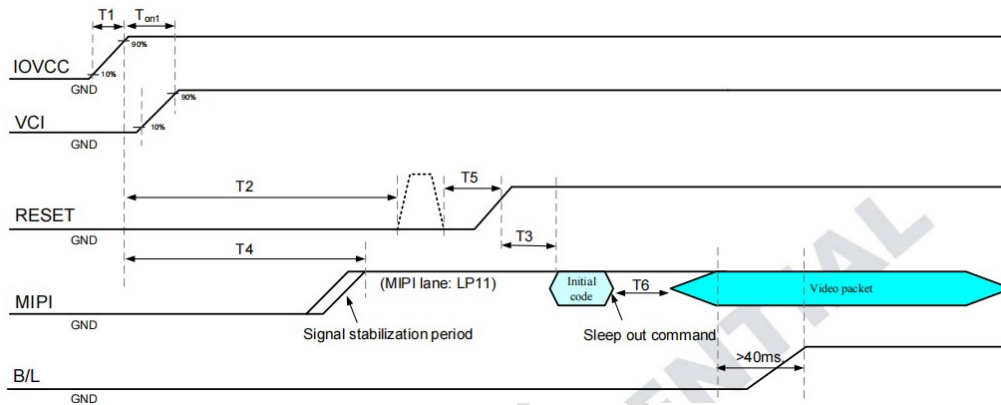

#### Power off:

Application Power: IOVCC, VCI,

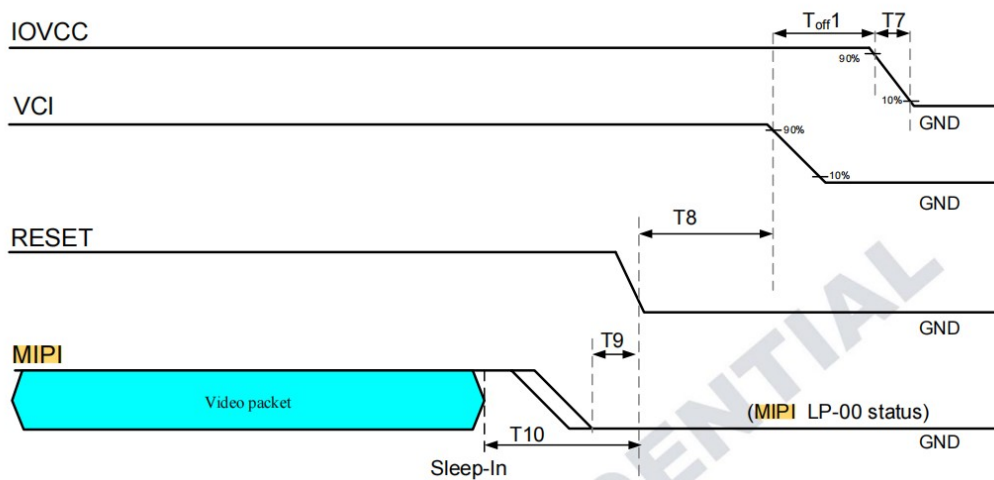

Note: Data include R0~R7, B0~B7, GO~G7, U/D, L/R, DCLK, HS, VS, DE.



#### 4.5 Power ON Sequence Timing

Item	symbol	Values			Unit	Remark
		Min	Typ	Max		
Delay time of IOVCC to VCI	Ton1	0	-	-	ms	
Delay time of IOVCC to VSP	Ton2	0	-	-	ms	
IOVCC rising time	T1	-	-	-	ms	
Delay time of IOVCC to valid RESX to "H"	T2	10	-	-	ms	
Delay time of RESX "H" to initial code ready	T3	20	-	-	ms	
Delay time of IOVCC (HS_VCC) to MIPI bus ready	T4	0	-	-	ns	
RESX "L" period	T5	10	-	-	us	
Delay time of initial code reloaded to video packet transmit	T6	120	-	-	ms	

#### 4.6 Power OFF Sequence Timing

Item	symbol	Values			Unit	Remark
		Min	Typ	Max		
Delay time of VCI to IOVCC	Toff1	0	-	-	ms	
Delay time of VSP to IOVCC	Toff2	0	-	-	ms	
Delay time of VSN to VSP	Toff3	0	-	-	ms	
IOVCC falling time	T7	-	-	-	ms	
Delay time of RESX "L" to VCI	T8	0	-	-	us	
Delay time of MIPI LP-00 to valid RESX "L"	T9	0	-	-	us	
Delay time of Sleep-in received to valid RESX "L"	T10	100	--	-	ms	
Delay time of RESX "L" to VSN	T11	0	-	-	ms	



## 5. Optical Specification

Item	symbol	Condition	Values			Unit	Remark
			Min	Typ	Max		
Viewing angle (CR ≥ 10)	$\theta_L$	$\Phi=180^\circ$ . (9 o'clock)	-	80	-	degree	Note 1
	$\theta_R$	$\Phi=0^\circ$ . (3 o'clock)	-	80	-		
	$\theta_T$	$\Phi=90^\circ$ . (12 o'clock)	-	80	-		
	$\theta_B$	$\Phi=270^\circ$ . (6 o'clock)	-	80	-		
Response time	T <sub>ON</sub>	Normal $\theta = \Phi = 0^\circ$ .	-	10	20	msec	Note 3
	T <sub>OFF</sub>		-	15	30	msec	
Contrast ratio	CR		800	1000	-	-	Note 4
Color chromaticity	W <sub>x</sub>		0.289	0.292	0.295	-	Note 2 Note 5 Note 6
	W <sub>y</sub>		0.320	0.323	0.326	-	
	R <sub>x</sub>		0.660	0.663	0.666	-	
	R <sub>y</sub>		0.317	0.320	0.323	-	
	G <sub>x</sub>		0.251	0.254	0.257	-	
	G <sub>y</sub>	0.576	0.579	0.582	-		
	B <sub>x</sub>	0.134	0.137	0.140	-		
B <sub>y</sub>	0.091	0.0946	0.0976	-			
Luminance L		450	500	-	Cd/m <sup>2</sup>	Note 6	
Luminance uniformity	Y <sub>u</sub>	70	75	-	%	Note 7	

### Test Conditions:

- DVDD=3.3V, IL=180mA (Backlight current), the ambient temperature is 25°C.
- The test systems refer to Note 2.

### Note 1:

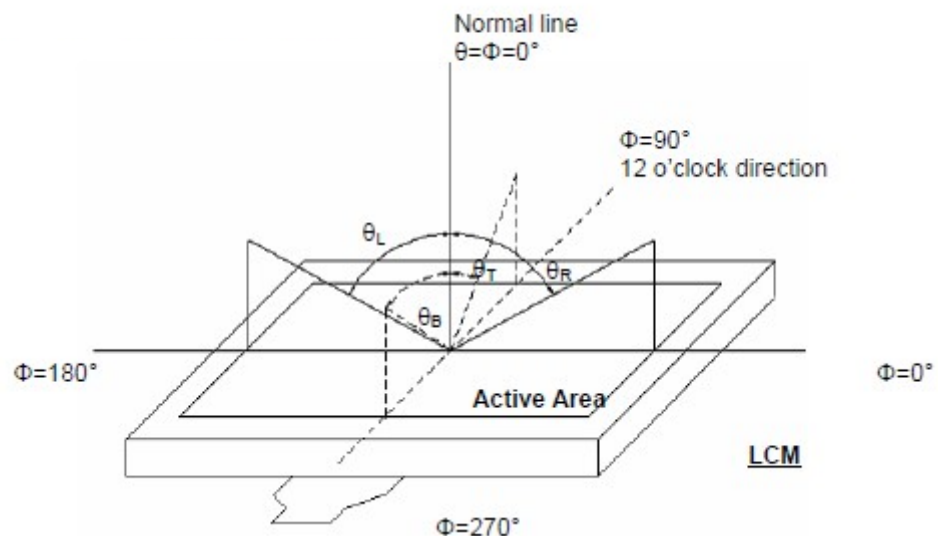

Note 2: Definition of optical measurement system.

The optical characteristics should be measured in dark room. After 30 minutes



operation, the optical properties are measured at the center point of the LCD screen. (Response time is measured by Photo detector TOPCON BM-7, other items are measured by BM-5A/Field of view: 1. /Height: 500mm.)

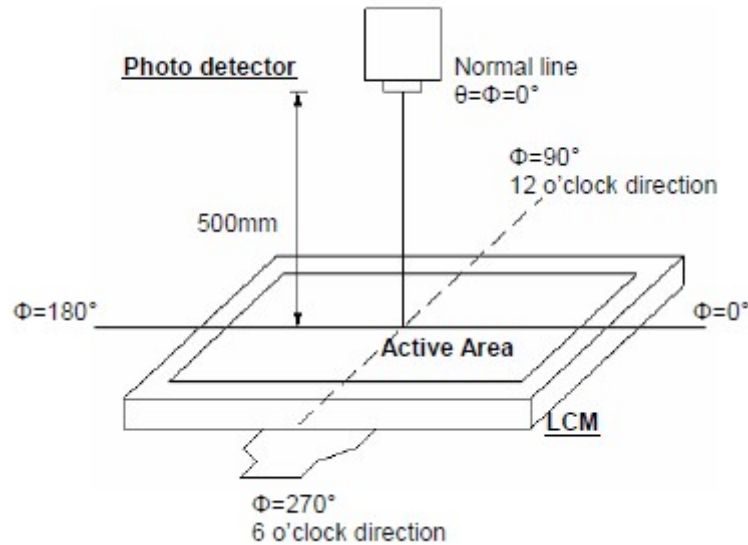

Note 3: Definition of Response time

The response time is defined as the LCD optical switching time interval between "White" state and "Black" state. Rise time (TON) is the time between photo detector output intensity changed from 90% to 10%. And fall time (TOFF) is the time between photo detector output intensity changed from 10% to 90%.

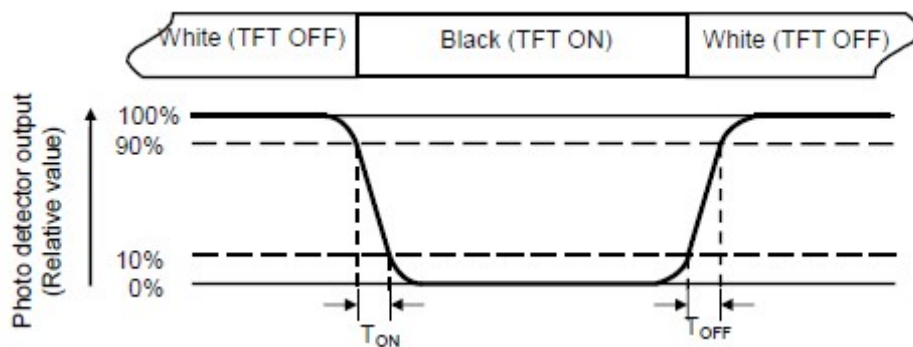

Note 4: Definition of contrast ratio

$$\text{Contrast ratio (CR)} = \frac{\text{Luminance measured when LCD on the "White" state}}{\text{Luminance measured when LCD on the "Black" state}}$$

Note 5: Definition of color chromaticity (CIE1931)

Color coordinates measured at center point of LCD.

Note 6: All input terminals LCD panel must be ground while measuring the center area of



the panel. The LED driving condition is IL=80mA .

Note 7: Definition of Luminance Uniformity

Active area is divided into 9 measuring areas (Refer to Fig. 4-4 ).Every measuring point is placed at the center of each measuring area.

$$\text{Luminance Uniformity (Yu)} = \frac{B_{\min}}{B_{\max}}$$

L-----Active area length      W----- Active area width

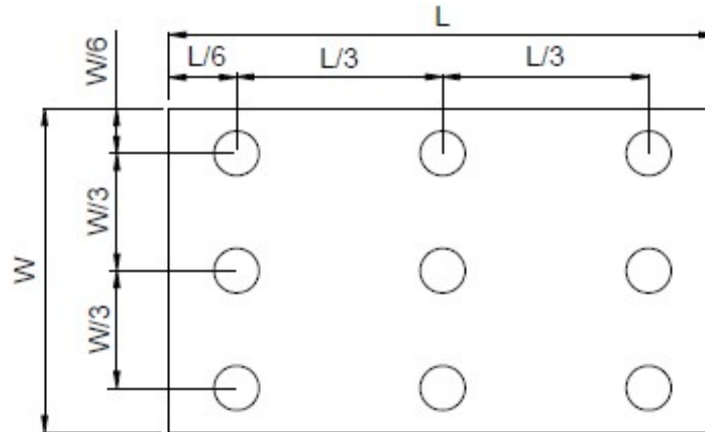

Bmax: The measured maximum luminance of all measurement position.

Bmin: The measured minimum luminance of all measurement position.

## 6. Reliability Test Items

Item	Test Conditions	Remark
High emperature Storage	Ta = 80°C 240hrs	
Low Temperature Storage	Ta = -30°C 240hrs	
High Temperature Operation	Ts = 70°C 240hrs	
Low Temperature Operation	Ta = -20°C 240hrs	
Operate at High Temperature and Humidity	+60°C, 90%RH 240hrs	
Thermal Shock	-30°C/30 min ~ +80°C/30 min for a total 100 cycles, Start with cold temperature and end with high temperature.	
Vibration Test	Frequency range:10~55Hz Stroke:1.5mm Sweep:10Hz~55Hz~10Hz 2 hours for each direction of X. Y. Z. (6 hours for total)	
Mechanical Shock	100G 6ms., ± X, . ± Y, . ± Z 3 times for each direction	
Package Vibration Test	Random Vibration : 0.015G*G/Hz from 5-200HZ, -6dB/Octave from 200-500HZ 2 hours for each direction of X. Y. Z. (6 hours for total)	
Package Drop Test	Height:60 cm 1 corner, 3 edges, 6 surfaces	
Electro Static Discharge	±2KV, Human Body Mode, 100pF/1500 Ω	

Note 1: Ta is the ambient temperature of samples.



东莞市科傲光电有限公司

DONG GUAN KAO ELECTRONICS CO., LTD

SPECIFICATION FOR LCD MODULE

文件编号

KAO-101BC-HD01

第 11 页, 共 13 页

Note 2:  $T_s$  is the temperature of panel's surface.

Note 3: In the standard condition, there shall be no practical problem that may affect the display function. After the reliability test, the product only guarantees operation, but don't guarantee all of the cosmetic specification.

Note 4: Before cosmetic and function test, the product must have enough recovery time, at least 2 hours at room temperature.

科傲光电



REV 版本	DESCRIPTION 描述	DATE 日期
A00	First issue	2020-5-20

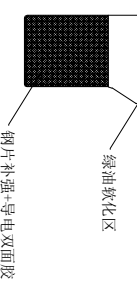
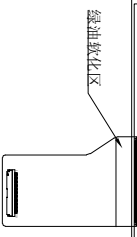
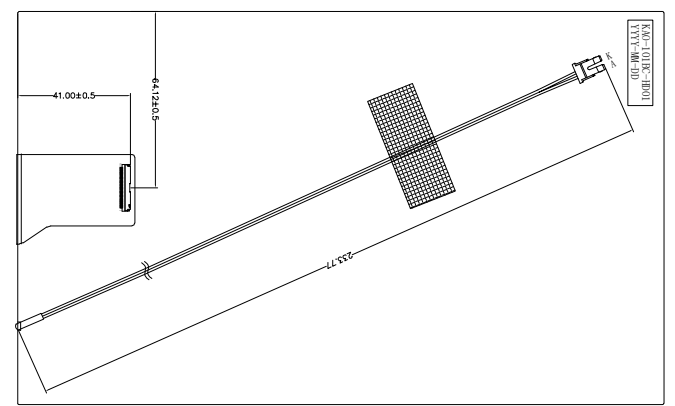
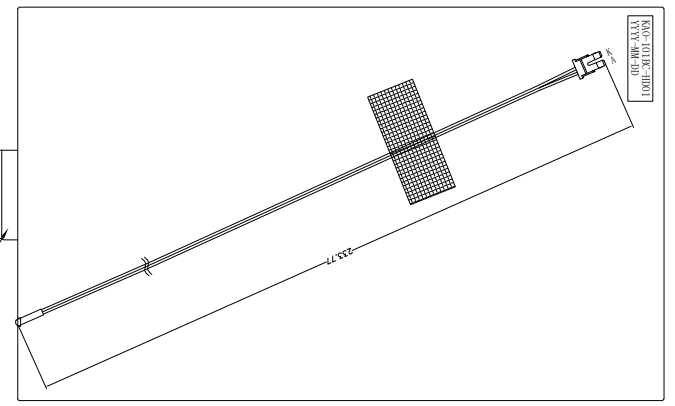
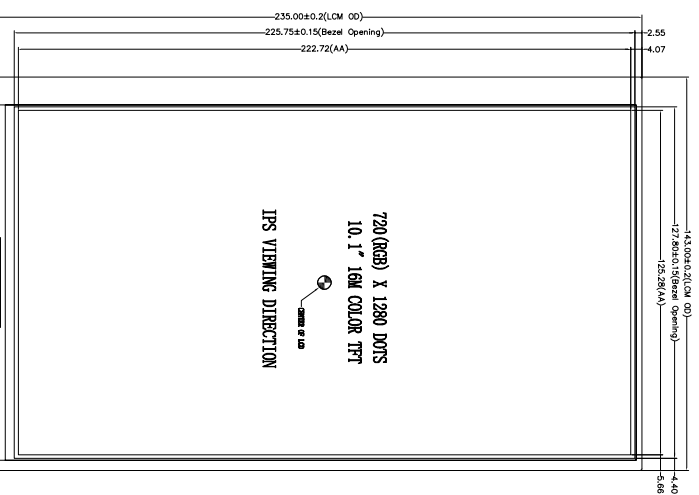

- NOTES:
1. DISPLAY TYPE: TFT-LCD, TRANSMISSIVE, NORMAL BLACK
  2. OPERATING TEMP: -20° C~60° C
  3. STORAGE TEMP: -30° C~70° C
  4. VIEWING DIRECTION: ALL
  5. BACK LIGHT Uniformity: 75% (Min)  
VF: 17V (Min); 18V (Typ); 19V (Max); IF: 120mA (Fix)
  6. Luminous intensity (9 AVG):  
Module: 350cd/m² (Min), 380cd/m² (Typ).
  7. GENERAL TOLERANCE: ±0.2

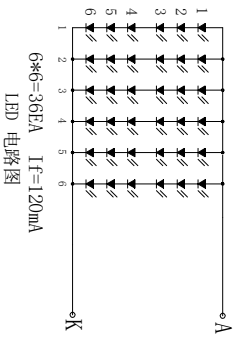

项目	Item	符号	最小值	典型值	最大值	单位	Condition
主屏 Main screen	模组亮度	Lv	350	380	--	cd/m <sup>2</sup>	6并@串: 120mA (恒定电流测试)
	均匀性 Uniformity	Avg	--	75	--	%	
	色度坐标	X	0.265	--	0.315		
	色度坐标	Y	0.27	--	0.32		
正向电压	Forward Voltage	Vf	--	3.0	--	V	
工作温度	Operating Temperature Range	Topr	-20	--	60	°C	
贮存温度	Storage Temperature Range	Tstg	-30	--	70	°C	

修改内容

修改者

修改日期

SCALE: FIT

1	根据要求修改PPC外形结构	Zhangwentong	2020-5-20	SHEET: 1 OF 5	GENERAL TOL: ±0.2	UNIT: mm	MODEL NUMBER: KAO-101BC-HD01	PROJECTION:	PART NO: KAO-101BC-HD01
2									
3									
4									
5									
6									

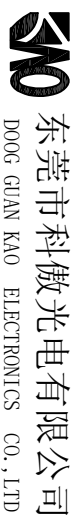

ASSY



东莞市科傲光电有限公司

DONG GUAN KAO ELECTRONICS CO., LTD

SPECIFICATION FOR LCD MODULE

文件编号

KA0-101BC-HD01

第 1 页, 共 7 页

# 出货检验标准书

## Shipping Inspection Standard

客户名称 (CUSTOMER NAME) :

\_\_\_\_\_

客户代码 (CUSTOMER CODE):

\_\_\_\_\_

产品名称 (DESCRIPTION) :

10.1 寸 LCM

产品编号 (PRODUCT CODE):

KA0-101BC-HD01

Dongguan Keao Photoelectric Co., Ltd. (科傲确认)		
核准	审核	制作
APPROVED BY	CHECKED BY	PREPARED BY
		张文通

Customer Comfirm (客户确认)		
核准	审核	确认
APPROVED BY	CHECKED BY	CONFIRM BY

电话 Tel: +86-769-39028875 13412418257

地址: 广东省东莞市塘厦镇田心恒盛隆工业区 B 栋二楼

网址: [www.keao-lcd.cn](http://www.keao-lcd.cn)





**LCD检验的必备要求：检验人员必须佩戴静电手环和静电手套或手指套**

**此标准适用于所有手机/电话机等显示模块，客户若更改标准按双方共同确认标准为准。**

## 1. 检查条件：

在 20~40W 日光灯的光照环境下，被检查样品放在离检查者眼睛30cm的位置，检查者在垂直方向  $45 \pm 15$  度区域内观察。

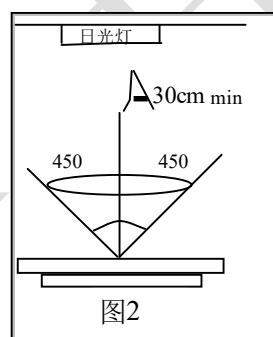

## 2. LCD 区域定义：

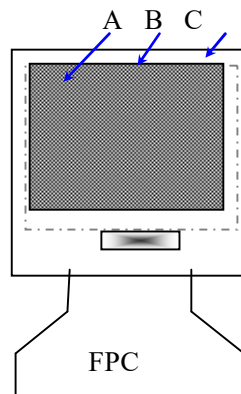

区域A：符号或数字显示区

区域B：视区（除A区）（A 区+B 区=最小视区，相对于模块确认图中的VA区范围）

区域 C：视区外围（模块确认图的VA 区外，客户机壳设计应参考此范围，装机后看不到此区域）。

注：在区域 C 中有看得见的缺陷，但不影响产品稳定性及客户产品组装，允许出货。



### 3. 检查标准

#### 3.1 重缺陷

NO.	检验项目	检验标准	缺陷等级
3.1.1	所有功能缺陷	1) 不显示、显示异常 2) 断笔、缺划、短路 3) 背光不亮, 或点亮不正常、闪烁 4) TP不触摸 5) 其他功能缺陷	重缺陷
3.1.2	遗漏	缺少任何元件	
3.1.3	尺寸超出	模块外观尺寸超出图纸上的规格值	

#### 3.2 外观缺陷:

NO.	检验项目	检验标准	缺陷等级		
3.2.1	刻痕 针孔 黑白点(异物点)	点状缺陷Φ的定义: $\Phi = \frac{(x+y)}{2}$ 	轻缺陷		
		串污: 点距≤10mm的两个或两个以上的点/线			
		区域尺寸 (mm)		最多允许数量	
				A      B      C	
		Φ ≤ 0.1		不计 (点间距5mm)	忽略不计
0.10 < Φ ≤ 0.15	N ≤ 2 (点距L ≥ 10mm)				
0.15 < Φ ≤ 0.2	N ≤ 1				
3.2.2	满天星 红/蓝斑	以ND卡10%覆盖, 目视距离30cm 5秒进行判定, 可见不接收。	轻缺陷		
3.2.3	线缺陷	尺寸 (mm)	最多允许数量		
		长度 (L)	宽度 (W)	区域	
				A区      B区      C区	
		忽略不计	W ≤ 0.02	忽略不计 (不允许串污)	忽略不计
		1.0 < L ≤ 2.0	0.01 < W ≤ 0.05	N ≤ 2 (点距 ≥ 10mm)	
2.0 < L ≤ 4.0	0.01 < W ≤ 0.05	N ≤ 1			

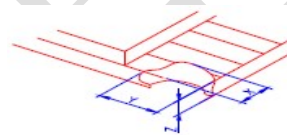
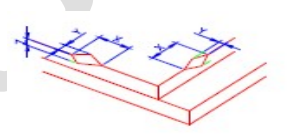
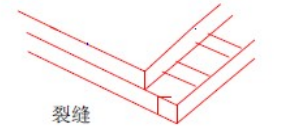

		尺寸 (mm)	最多允许数量											
			区域											
			A区	B区	C区									
3.2.4	偏光片气泡 (气泡偏光片与玻璃之间)	$\Phi \leq 0.1$ $0.10 < \Phi \leq 0.20$ $0.20 < \Phi \leq 0.25$ $0.25 < \Phi$	忽略不计 (不允许串污)	2 (点距 $\geq 20\text{mm}$ )	$N \leq 1$	$N \leq 0$	忽略不计	轻缺陷						
3.2.5	偏光片位置	1) 偏光片张贴要附合图纸要求, W 偏差 $\leq 1/2\text{LCD}$ 黑边框, 同时不允许超出玻璃边缘。 2) 偏光片必须完全覆盖显视区, 偏光片至少与封框胶相交 (图纸有特别要求的除外)。需要点银胶的产品, 偏光片贴附必须避开银胶位置。					轻缺陷							
3.2.6	玻璃缺陷	(i) 破碎在边角		<table border="1"> <tr> <th>X</th> <th>Y</th> <th>Z</th> </tr> <tr> <td><math>\leq 3.0</math></td> <td><math>\leq S</math></td> <td>不考虑</td> </tr> </table> 注: S=引线脚长度 破碎边角破碎不允许延伸到ITO引线部分, 不允许进入封口。		X	Y	Z	$\leq 3.0$	$\leq S$	不考虑			轻缺陷
		X	Y	Z										
		$\leq 3.0$	$\leq S$	不考虑										
(ii) 常见表面破损		<table border="1"> <tr> <th>X</th> <th>Y</th> <th>Z</th> </tr> <tr> <td><math>\leq 3.0</math></td> <td>不超过封胶外线</td> <td>不考虑</td> </tr> </table>		X	Y	Z	$\leq 3.0$	不超过封胶外线	不考虑			轻缺陷		
X	Y	Z												
$\leq 3.0$	不超过封胶外线	不考虑												
(iii) 裂痕		不允许有延伸趋势的裂痕				重缺陷								
3.2.7	色差	模块的颜色和亮度范围参考各个型号的规格书及参考极限样板					重缺陷							
3.2.8	喷码	未喷码		不允许		重缺陷								
		喷码模糊		不允许		轻缺陷								
3.2.9	背光	1) 亮度与颜色按样板, 具体可参考相关的极限样板 2) 污点与黑白点: 同清晰点标准 3) 划伤及线缺陷, 同3.2.2 线缺陷标准 4) 正常不允许漏光, 特殊可参考极限样板。					轻缺陷							
3.2.10	铁框翘起	按图纸或规格书尺寸, 0.3mm 以内为允许(只限于图纸及产品规格书为规定时)					轻缺陷							
3.2.11	LCD与背光分离	不允许					重缺陷							
3.2.12	焊接问题	短路、虚焊、假焊、锡珠、锡渣、焊偏 $> 1/3$ 等不允许					重缺陷							
3.2.13	FPC问题	FPC压痕	不导致导体锐角变形, 轻微光滑折痕允许			重缺陷								



3.2.13	FPC问题	FPC划伤	焊盘/走线区域划伤: 长度 $\leq$ 1.0MM, 宽度 $\leq$ 0.05MM; 不允许露铜 无走线区域: 不允许露铜	重缺陷
		FPC金手指断	不影响产品正常焊接及可靠性允许	
		FPC金手指粘锡	不影响正常使用情况允许	
		FPC少元件	不允许	
		元件虚焊、假焊		
		元件落错		
		焊盘氧化	出现明显的变色(如变白或变黑)	
脏污	参考极限样板			

### 3.3、功能测试

3.3.1 LCD Module 功能测试, 一般依据设计提供的该产品的标准测试软件和夹具进行。因产品而异, 随具体项目具体给出夹具功能测试方法(包括需检查项和对应的检测画面)。

3.3.2 对项目中所列测试项, 如某一项异常, 则说明产品功能存在相应缺陷。

3.3.3 测试第一次失败, 重新连接测试通过, 则测试认为通过。

功能检验标准参照以下标准

NO	检查项目	判定基准	缺陷区分	现象定义
1	断路	不允许	重缺陷	正常显示时, 此处图案或文字不显示
2	短路	不允许	重缺陷	正常显示时, 此处多出一条或多条线, 伴随大电流现象。
3	显示异常	不允许	重缺陷	出现与正常显示不一样的现象
4	不显示	不允许	重缺陷	完全不能显示的现象
5	少画面	不允许	重缺陷	显示画面比规格书要求少
6	大电流	不允许	重缺陷	比规格书要求的最大.消耗电流值更高
7	CROSS-TALK	不允许, 必要时制定限度样品	重缺陷	不需要的图案或文字符号显示的现象
8	对比度差异	不允许, 必要时制定限度样品		以部分性的出现深或浅的现象
9	视角错	不允许	重缺陷	以部分性的出现深或浅的现象
10	背光亮度差异	标准样本为准, 必要时依限度样品		整体上的亮度比标准样本差异为20%的现象
11	不亮	不允许	重缺陷	背光灯不亮



### 3.4 可靠性实验:

按以下项目进行可靠性实验, 如客户有特殊要求时, 则按客户要求实验。实验数量5~10PCS/每组实验。

测试项目	测试条件
温度循环	60℃ 30分钟,-30℃ 30分钟,每个循环为1 个小时, 共10 个循环,
高温高湿(通电)	50℃ 90±3%RH,24h , 降至常温2 小时后检测
低温存储	-30℃ 48 小时
高温存储	+60℃ 48小时
包装跌落	高度: 50cm 六个面二个棱一角方向及次数: 一面/棱/角一次
静电	LCM 模组,空气放电+8kv,接触放电+4kv
震动实验	针对所有带TP的型号, 震动时间为四小时, 数量为100PCS
高温通电	60℃, 24 小时
低温通电	-20℃, 24 小时

### 3.5 包装检查:

NO	检查项目	判定标准	现象
1	包装箱形态	参照产品制造规格书	
2	包装方法	参照产品制造规格书	
3	数量	参照产品制造规格书	
4	印刷	参照产品制造规格书	◆印刷物的颜色, 形态, 尺寸及位置和包装规格不同现象
5	附着物	参照产品制造规格书	◆附着物的颜色, 形态, 尺寸及位置和包装规格不同或附着状态不良现象
6	箱子破坏状态	参照产品制造规格书	
7	装载状态	参照产品制造规格书	◆盘子的装载状态(特别是PVC TRAY)与包装规格不同现象

### 3.7、产品尺寸检查:

参考产品图纸或者规格书

### 4.0、抽样计划:

#### 4.1、2828-2003.1 进行抽样检验,AQL 定义如下:

一般检验水准II级: Major Defect =0.4 ; Minor Defect =0.65;