

Specification

Product Type: 10.1' TFT LCD Module
Module No. : TY101GLI300

CUSTOMER	PREPARE BY	CHECK BY	APPROVED BY
APPROVED			

Preliminary Specification

Final Specific

Contents

No.	Items	Page
1.0	General Description	3
2.0	Absolute Maximum Ratings	5
3.0	Electrical Specifications	6
4.0	Optical Specifications	15
5.0	Reliability Test	18
6.0	Packing Information	19
7.0	Handling & Cautions	20
8.0	Mechanical Drawing	24

1.0 GENERAL DESCRIPTION

1.1 Introduction

TY101GLI300 is a color active matrix TFT LCD FOB using amorphous silicon TFT's (Thin Film Transistors) as an active switching devices. This module has a 10.1 inch diagonally measured active area with WXGA resolutions (1280 horizontal by 800 vertical pixel array). Each pixel is divided into RED, GREEN, BLUE dots which are arranged in vertical stripe and this module can display 16.7M colors.

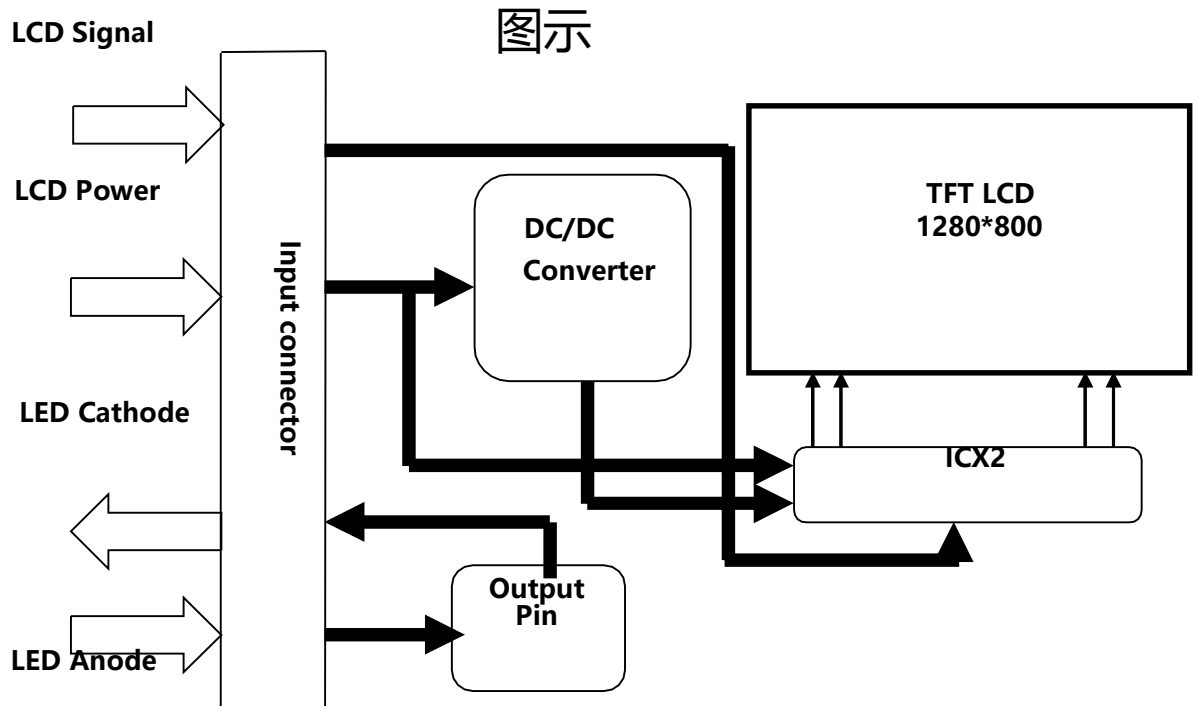

1.2 Features

- LVDS Interface;
- 6bit + Hi-FRC display 16.7M colors
- High contrast ratio and Transmittance

1.3 Application

- Industrial Instruments etc.

1.4 General Specification

The followings are general specifications.

<Table 1. LCD Module Specifications>

Parameter	Specification	Unit	Remarks
Active Area	216.96(H)*135.6(V)	mm	
Number Of Pixels	1280(H)×800(V)	pixels	
Pixel Pitch	0.0565(H)×RGB×0.1695(V)	mm	
Pixel Arrangement	Pixels RGB stripe arrangement		
Display Mode	Normally Black		
Display Colors	16.7M(6bit +Hi-FRC)	colors	
Luminance	300 cd/m2		
Contrast Ratio	1000:1(typ.)		
Viewing Angle(CR> 10)	80/80/80/80(typ.)		
Response Time	35(typ.)/40(max.)	ms	
Color Gamut	50%NTSC		
Power Consumption	Panel: 0.6(Typ.) 0.94 (Max.)	watt	typ@Mosai c8x 6 max@1DOT
Outline Dimension	229.25(L)*149.05(W)*2.6(H)	mm	

2.0 ABSOLUTE MAXIMUM RATINGS

The followings are maximum values which, if exceed, may cause faulty operation or damage to the unit.

< Table 2. Environment Absolute Maximum Ratings >

Parameter		Symbol	Min.	Max.	Unit	Remarks
Power Supply	LCD Module	VDD	VSS-0.3	3.6	V	Ta = 25 °C Note 1&2
Operating Temperature		T _{OP}	-20	+70	°C	
Storage Temperature		T _{ST}	-30	+80	°C	

Note:

1. These range above is maximum value not the actual operating temperature . Actual Operating temperature is no more than 40°C and temperature refers to the LCM surface temperature ;
2. Wanty is not responsible for product problems beyond the use conditions.

3.0 ELECTRICAL SPECIFICATIONS

3.1 TFT LCD Module

< Table 3. LCD Module Electrical specifications > [Ta=25±2 °C]

Parameter	Symbol	Values			Unit	Notes
		Min.	Typ.	Max.		
Power Supply Voltage	VDD	3.0	3.3	3.6	V	
	VRP			300	mV	Ripple
Power Supply Current	IDD	-	127	343	mA	Note 1
Power Consumption	PLCD	-	0.42	1.13	W	
Rush current		IRUSH	-	-	3.0	A
CMOS Interface	Input Voltage	VIH	2.7		3.3	V
		VIL	0		0.5	V
	Output Voltage	VOH	2.7		3.3	V
		VOL	0		0.5	V

Notes : 1. The supply voltage is measured and specified at the interface connector of LCM.
The current draw and power consumption specified is for VDD=3.3V, Frame rate $f_v=60\text{Hz}$ and Clock frequency = 72.4MHz. Test Pattern of power supply current

a) Typ : Mosaic 8 x 6 Pattern(L0/L255)

b) Max : skip subPixel(L255)

3.0 ELECTRICAL SPECIFICATIONS

3.2 Back-light Unit

< Table 4. LED Driving guideline specifications > [Ta =25±2 °C]

Parameter	Symbol	Values			Unit	Notes	
		Min.	Typ.	Max.			
LED Power supply Input voltage	VLED	5	12	18	V	-	
Power supply voltage for Back light	VLED	-	-	21	V	-	
Power supply current for Back light	ILED	-	120	-	mA	-	
EN Control level	Backlight on	VENH	1.2	-	18	V	En logic high voltage
	Backlight off	VENL	-	-	0.4		En logic low voltage
PWM Control level	PWM High Level	VPWH	1.2	-	18	V	-
	PWM Low Level	VPWL	-	-	0.4		-
PWM Control	PWM duty Ratio		1	-	-	%	-
	PWM Frequency	FPWM	5	-	100	KHZ	-

3.3 INPUT TERMINAL PIN ASSIGNMENT

This LCD employs one interface connections, a 40 pin connector is used for the LCD module electronics interface.

3.3.1 Pin assignment for LCD module

Connector : MSAK24025P40G (STM) or equivalent

< Table5. Pin Assignment for LCD Module Connector >

Pin No.	Symbol	Description	I/O
1	NC	Non Connection	-
2	VDDIN	Power supply VDDIN=3.3V (Typ.)	P
3	VDDIN		P
4	VDDIN		P
5	NC	Non Connection	-
6	GND	GROUND	P
7	GND	GROUND	P
8	RIN0-	LVDS Negative data signal (-)	I
9	RIN0+	LVDS Positive data signal (+)	I
10	GND	GROUND	P
11	RIN1-	LVDS Negative data signal (-)	I
12	RIN1+	LVDS Positive data signal (+)	I
13	GND	GROUND	P
14	RIN2-	LVDS Negative data signal (-)	I
15	RIN2+	LVDS Positive data signal (+)	I
16	GND	GROUND	P
17	LVDS_CLK-	LVDS Negative CLK signal (-)	I
18	LVDS_CLK+	LVDS Positive CLK signal (+)	I
19	GND	GROUND	P
20	RIN3-	LVDS Negative data signal (-)	I

深圳市万天源光电有限公司
Shenzhen Wanty Photoelectric Co., Ltd

Pin No.	Symbol	Description	I/O
21	RIN3+	LVDS Positive data signal (+)	I
22	GND	GROUND	P
23	NC	Non Connection	-
24	NC	Non Connection	-
25	GND	GROUND	P
26	SCL_S	Reserved for LCD manufacturer' s use , not connection	-
27	SDA_S	Reserved for LCD manufacturer' s use , not connection	-
28	GND	GROUND	P
29	NC	Non Connection	-
30	NC	Non Connection	-
31	GND	GROUND	P
32	GND		
33	GND		
34	NC	Non Connection	-
35	LED_PWM	LED PWM signal pin	O
36	NC	Non Connection	-
37	NC	Non Connection	-
38	LED+	LED Anode	P
39	LED+		P
40	LED+		P

3.4 Interface timing Parameter

< Table5. LVDS Timing Parameter >

Parameter	Symbol	Value			Unit
		Min.	Typ.	Max.	
DCLK Frequency	Fdclk	66.3	72.4	78.9	MHz
Horizontal display area	Thd	1280			pixel
HSYNC period time	Th	1380	1440	1500	pixel
HSYNC blanking	thbp+ thfp	100	160	220	pixel
Vertical display area	Tvd	800			H
Frequency	fV	55	60	65	Hz
VSYNC period time	Tv	824	838	872	H
VSYNC blanking	Tvbp+ Tvfp	24	38	72	H

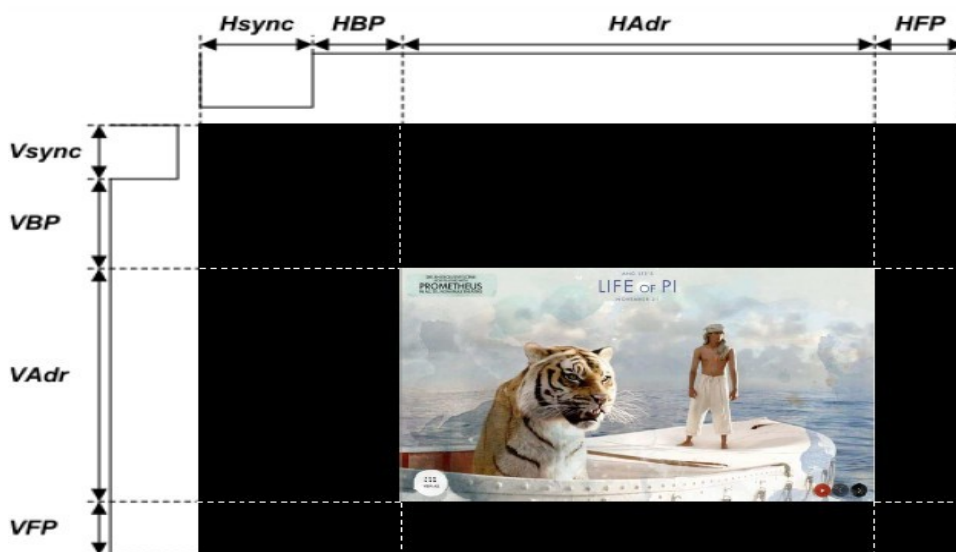

深圳市万天源光电有限公司
Shenzhen Wanty Photoelectric Co., Ltd

<Table 6. LVDS AC Timing Specification>

Item	Symbol	Min	Typ	Max	Unit	Remark
Clock frequency	RxFCLK	30	-	TBD	MHz	Refer to input timing table for each display resolution
Input data skew margin	TRSKM	500	-	-	ps	VID = 200mV RxVCM = 1.2V RxFCLK = 81MHz
Clock high time	TLVCH	-	$4/(7 * RxFCLK)$	-	ns	
Clock low time	TLVCL	-	$3/(7 * RxFCLK)$	-	ns	
PLL wake-up time	TenPLL	-	-	150	us	
Clock frequency	RxFCLK	30	-	TBD	MHz	Refer to input timing table for each display resolution
Input data skew margin	TRSKM	500	-	-	ps	VID = 200mV RxVCM = 1.2V RxFCLK = 81MHz
Clock high time	TLVCH	-	$4/(7 * RxFCLK)$	-	ns	
Clock low time	TLVCL	-	$3/(7 * RxFCLK)$	-	ns	

3.4 Interface timing Parameter

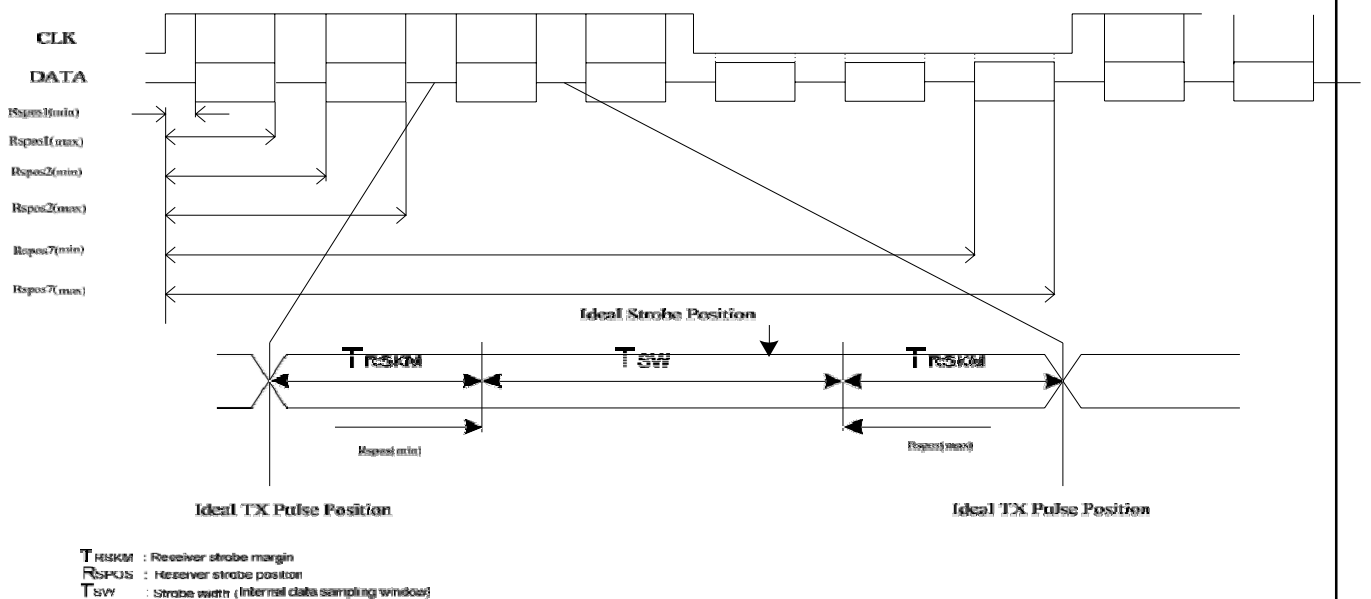
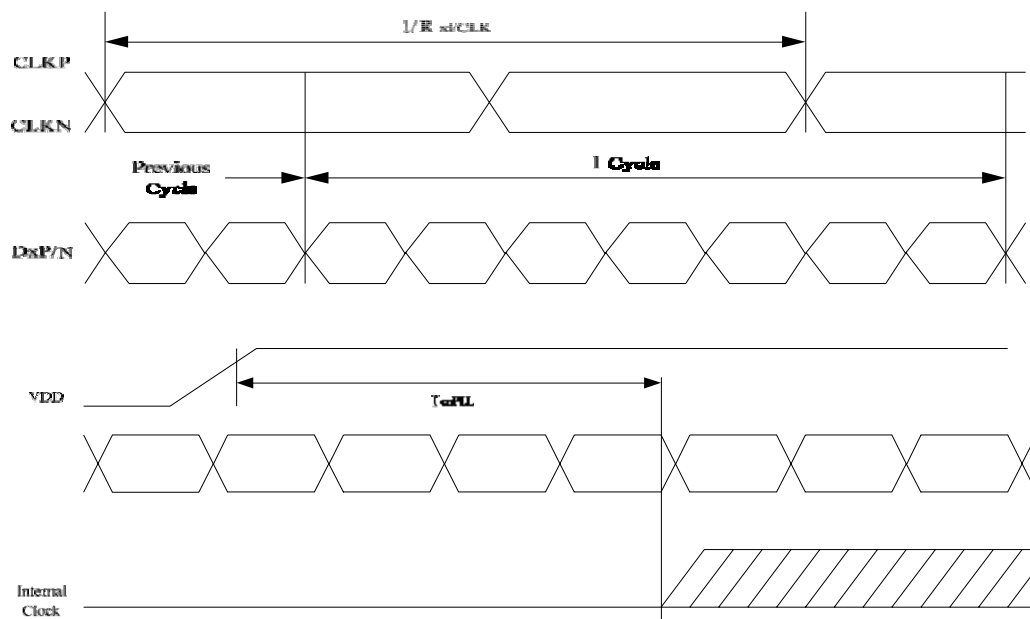

<Table7. LVDS DC Timing Specification>

Parameter	Symbol	Min.	Typ.	Max.	Unit	Condition
Differential input high threshold voltage	RXVTH	+0.1	0.2	0.3	V	RXVCM=1.2V
Differential input low threshold voltage	RXVTL	-0.3	-0.2	-0.1	V	
Input voltage range (singled-end)	RXVIN	0.7	-	1.7	V	
Differential input common mode voltage	RXVCM	1	1.2	1.4	V	VID =0.2
Differential input impedance	ZID	80	100	125	ohm	
Differential input voltage	VID	0.2	-	0.6	V	
Differential input leakage current	ILCLVDS	-10	-	+10	uA	
LVDS Digital Operating Current	IVDDMIP I	-	15	20	mA	FDCLK=80MHz, VDD=3.3V, Input pattern: 55h->Aah->55h->Aah
LVDS Digital Stand-by Current	ISTMIPI	-	-	250	uA	Clock & all Functions are stopped

Single-end Signals

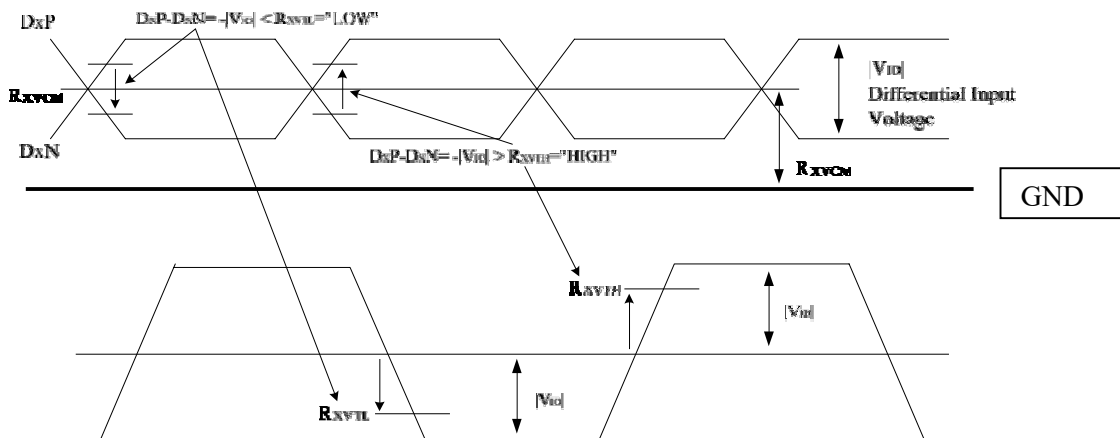

3.5 Power Sequence

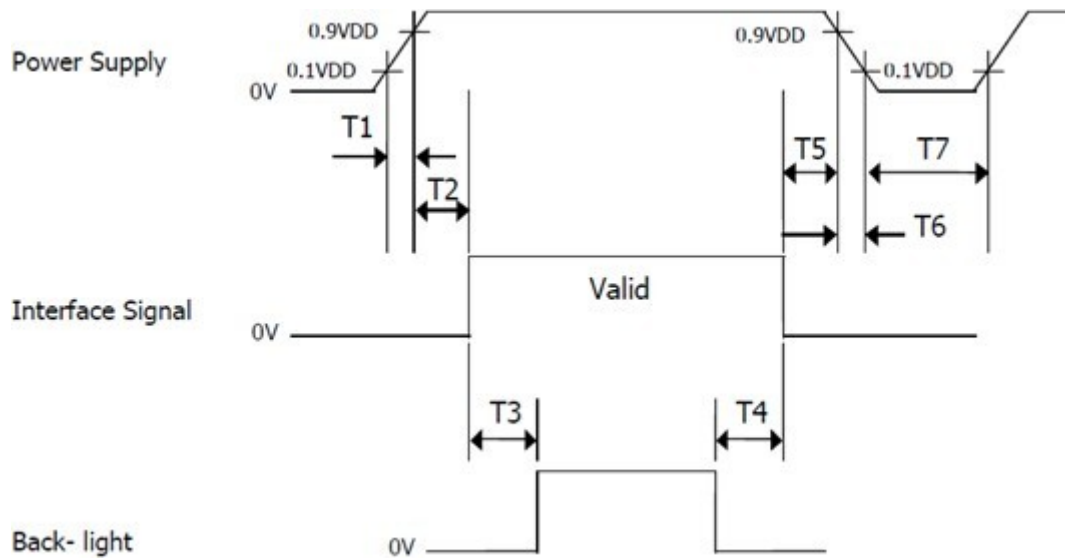

< Table8. Sequence Table >

Parameter	Values			Units
	Min	Typ	Max	
T1	0	-	10	ms
T2	0	-	50	ms
T3	200	-	-	ms
T4	500	-	-	ms
T5	0	-	50	ms
T6	0	-	10	ms
T7	500	-	-	ms

4.0 OPTICAL SPECIFICATIONS

4.1 Overview

The test of optical specifications shall be measured in a dark room (ambient luminance ≤ 1 lux and temperature = $25\pm 2^\circ\text{C}$) with the equipment of Luminance meter system (Gonio meter system and TOPCON BM-5) and test unit shall be located at an approximate distance 50cm from the LCD surface at a viewing angle of θ and Φ equal to 0° . We refer to $\theta\Phi=0$ ($=\theta 3$) as the 3 o' clock direction (the "right"), $\theta\Phi=90$ ($=\theta 12$) as the 12 O' clock direction ("upward"), $\theta\Phi=180$ ($=\theta 9$) as the 9 O' clock direction ("left") and $\theta\Phi=270$ ($=\theta 6$) as the 6 O' clock direction ("bottom"). While scanning θ and/or Φ , the center of the measuring spot on the Display surface shall stay fixed.

4.2 Optical Specifications < Table9. Optical Table >

Item	Symbol	Condition	Min	Typ.	Max	Unit	Note
Viewing Angle	θ_L	$Cr \geq 10$	70	80	--	deg	Note 1
	θ_R		70	80	--		
	ψ_T		70	80	--		
	ψ_B		70	80	--		
Contrast Ratio	Cr	$\theta=0^\circ$ $FF=0^\circ$	--	1000		-	Note 2
Response Time	Tr+Tf		--	30	35	ms	Note 3
Color Coordinate of CIE1931	Rx	$\theta=0^\circ$	0.588	0.618	0.648	-	Note 4 @C光
	Ry		0.299	0.329	0.359		
	Gx		0.253	0.283	0.313		
	Gy		0.512	0.542	0.572		
	Bx		0.109	0.139	0.169		
	By		0.134	0.164	0.194		
	Wx		0.269	0.299	0.329		
	Wy		0.309	0.339	0.369		
NTSC Ratio	NTSC	CIE1931	45	50	--	%	Note 5
Polarization Direction of Front Polarizer	PdF	-		0		deg	Absorption axis Note 7
Polarization Direction of Rear Polarizer	PdR			90		deg	

Note 1: The definition of Viewing Angle

Refer to the graph below marked by θ and ϕ .

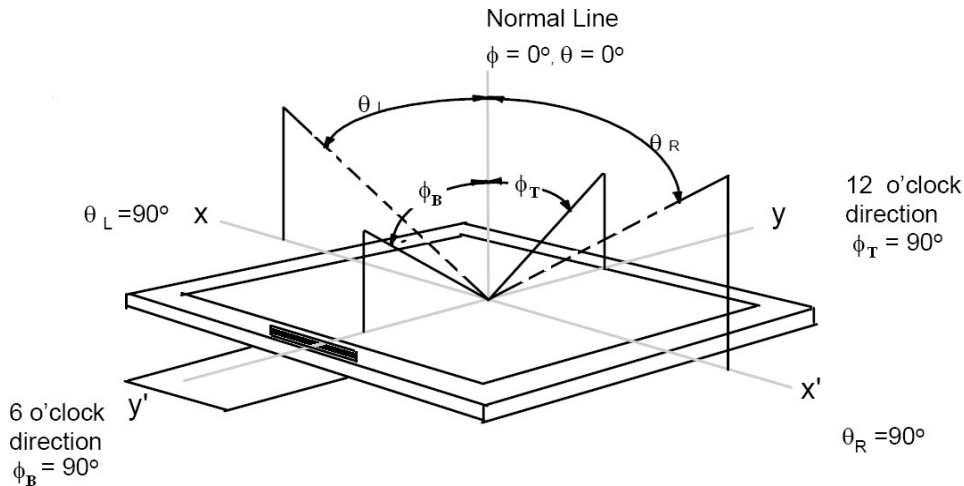

Note 2: The definition of Contrast Ratio

$$\text{Contrast Ratio (CR)} = \frac{\text{Luminance When LCD is at "White" state}}{\text{Luminance When LCD is at "Black" state}}$$

(Contrast Ratio is measured in optimum common electrode voltage)

Note 3: Definition of Response time. (Test LCD using RD80S or similar equipments):

The output sign also photo detector are measured when the input sign also are changed from "black" to "white" (Voltage falling time) and from "white" to "black" (Voltage rising time), respectively. The response time is defined as the time interval between the 10% and 90% of amplitudes. Refer to figures below.

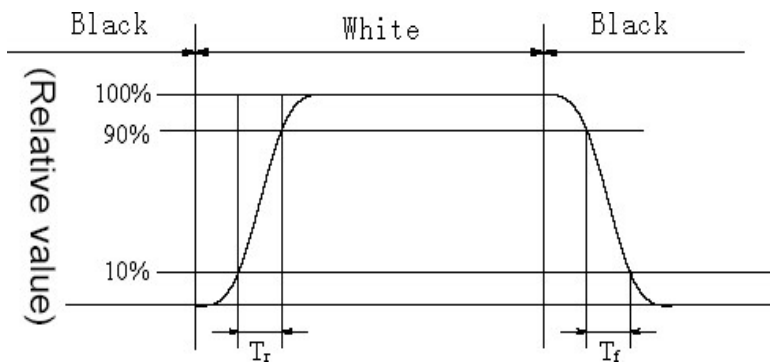

Note 4: Color Coordinates of CIE 1931

The test condition is at ILED=20mA and measured on the surface of LCD module at 25°C. Measurement equipment: CS2000 or similar equipments

The Color Coordinate (CIE 1931) is the measurement of the center of the display shown in below figure.

Note 5: Definition of Color of CIE Coordinate and NTSC Ratio.

$$S = \frac{\text{area of RGB triangle}}{\text{area of NTSC triangle}} \times 100\%$$

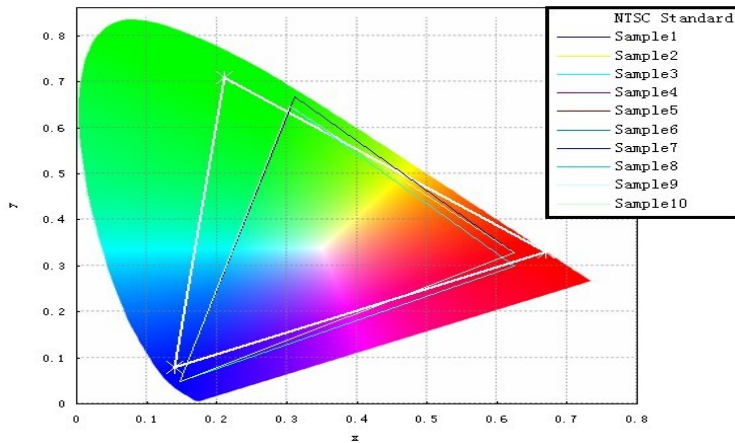

Note 6: Polarization Direction Definition

- Viewing direction is normal user viewing direction which is vertical to the display surface
- The polarizer which is closer to viewer is defined as Front Polarizer
- The polarizer which is on the rear side of viewer is defined as Rear Polarizer
- The X axis is defined as parallel line to top & bottom sidelines of the Active Area
- PdF which is marked in blue arrow is polarization degree of Front polarizer
- PdR which is marked in red arrow is polarization degree of Back polarizer
- The polarization degree parameter must be indicated in range of 0deg to 180deg according to above definition

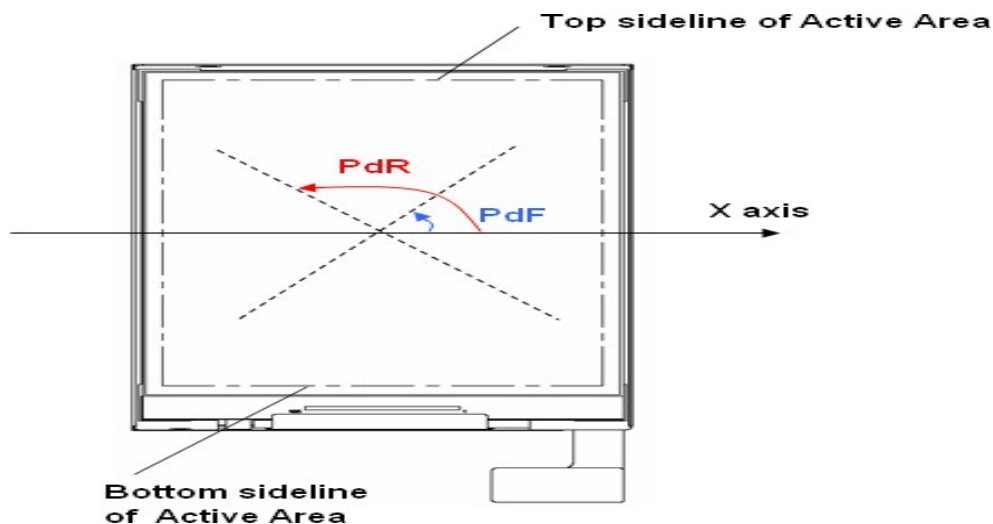

5.0 RELIABILITY TEST

The Reliability test items and its conditions are shown in below.

<Table 8. Reliability Test Parameters >

No	Test Items	Conditions
1	High temperature storage test	80°C 240hr
2	Low temperature storage test	-30°C 240hr
3	Low temperature operation test	-20°C 240hr
4	High temperature operation test	70°C 240hr
5	High temperature & high humidity (operation test)	60°C 90%RH 240hr
6		
7		
8		
9		
10		
...		

6.0 PACKING INFORMATION(产品形态: LCM)

Packing procedure:

- 将 2pcs Panel平放入Tray, CF 侧向上放置;
- 上下各1pcs EPE Spacer
- 将20pcs PET Tray 平放入Shielding Bag
- 抽真空
- 顶部1pcs 空Tray

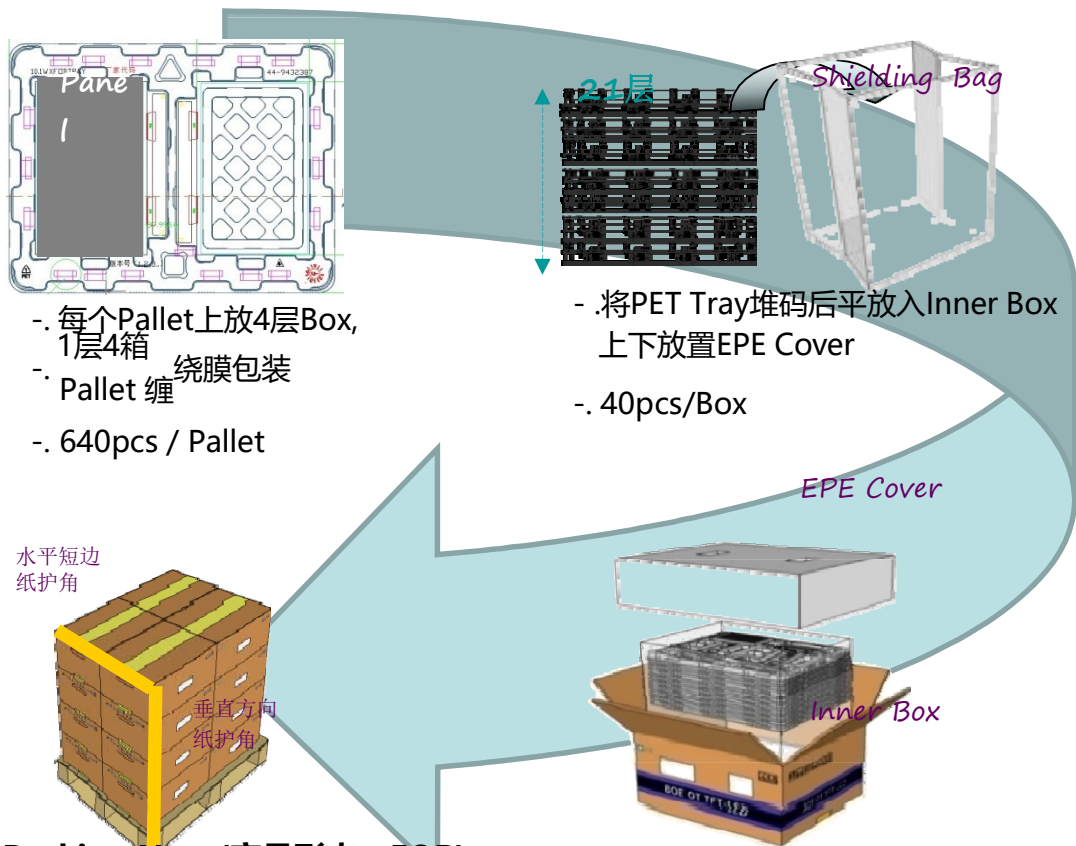

6.1 Packing Note(产品形态: FOB)

- Box Dimension: 510mm(W) x 410mm(D) x 252mm(H)
- Package Quantity in one Box: 40pcs

- **7.0 Precautions**

- Please pay attention to the followings when you use this TFT LCD Panel.

- **7.1 Mounting Precautions**

- (1) Use fingerstalls with soft gloves in order to keep display clean during the incoming inspection and assembly process.
- (2) You must mount a module using specified mounting holes (Details refer to the drawings).
- (3) Please make sure to avoid external forces applied to the Source PCB or FPC and D-IC during the process of handling or assembling. If not, It causes panel damage or malfunction.
- (4) Note that polarizers are very fragile and could be easily damaged. Do not touch, push or rub the exposed polarizers with glass, tweezers or anything harder than HB pencil lead. And please do not rub with dust clothes with chemical treatment.
- (5) Do not pull or fold the source D-IC which connect the source PCB or FPC and the panel.
- Do not pull or fold the LED wire.
- (6) After removing the protective film, when the surface becomes dusty, please wipe gently with absorbent cotton or other soft materials like chamois soaks with alcohol or purified water.
- Do not strong polar solvent because they cause chemical damage to the polarizer.
- (7) Wipe off saliva or water drops as soon as possible. Their long time contact with polarizer causes deformations and color fading.
- (8) Protection film for polarizer on the module shall be slowly peeled off just before use so that the electrostatic charge can be minimized.
- (9) Since the LCD is made of glass, do not apply strong mechanical impact or static load onto it. Handling with care since shock, vibration, and careless handling may seriously affect the product. If it falls from a high place or receives a strong shock, the glass may be broken.
- (10) Do not disassemble the module.
- (11) To determine the optimum mounting angle, refer to the viewing angle range in the specification for each model.
- (12) If the customer's set presses the main parts of the LCD, the LCD may show the abnormal display. But this phenomenon does not mean the malfunction of the LCD and should be pressed by the way of mutual agreement.
- (13) Do not drop water or any chemicals onto the LCD's surface.

7.2 Operating Precautions

- (1) Be careful for condensation at sudden temperature change. Condensation makes damage to polarizer or electrical contacted parts. And after fading condensation, smear or spot will occur.
- (2) Module has high frequency circuits. Sufficient suppression to the electromagnetic interference shall be done by system manufacturers. Grounding and shielding methods may be important to minimized the interference.
- (3) The electrochemical reaction caused by DC voltage will lead to LCD degradation, so DC drive should be avoided.
- (4) The LCD modules use C-MOS LSI drivers, so customers are recommended that any unused input terminal would be connected to Vdd or Vss, do not input any signals before power is turn on, and ground you body, work/assembly area, assembly equipments to protect against static electricity.
- (5) Do not exceed the absolute maximum rating value. (supply voltage variation, input voltage variation, variation in part contents and environmental temperature, and so on) Otherwise the Module may be damaged.
- (6) Design the length of cable to connect between the connector for back-light and the converter as short as possible and the shorter cable shall be connected directly. The longer cable between that of back-light and that of converter may cause the luminance of LED to lower and need a higher startup voltage(Vs).
- (7) Connectors are precise devices for connecting PCB and transmitting electrical signals. Operators should insert and unplug MDL in parallel when assembling MDL.
- (8) Do not connect or disconnect the cable to/ from the module at the "Power On" condition.
- (9) When the module is operating, do not lose CLK, ENAB signals. If any one these signals is lost, the LCD panel would be damaged.
- (10) Obey the supply voltage sequence. If wrong sequence is applied, the module would be damaged.
- (11) Do not re-adjust variable resistor or switch etc.
- (12) For the Q/Single/OC Product, If the LED designed side view, LED bar should be putted in the Long/short side; Otherwise, its reliability and function may not be guaranteed.

注:

- ①(1)涉及到Pol相关条目适用于OC/MDL出货产品,
- ②(6)(7)涉及到connector相关适用于OC/MDL出货产品
- ③(12)涉及到客户进行BLU设计, LED Bar位置需要避开GOA位置;

7.3 Electrostatic Discharge Control

- (1) Since a module is composed of electronic circuits, it is not strong to electrostatic discharge. Make certain that treatment persons are connected to ground through wrist band etc. And don't touch interface pin directly. Keep products as far away from static electricity as possible.
- (2) Avoid the use work clothing made of synthetic fibers. We recommend cotton clothing or other conductivity-treated fibers.

7.4 Precautions for Strong Light Exposure

It is not allowed to store or run directly in strong light or in high temperature and humidity for a long time; Strong light exposure causes degradation of polarizer and color filter.

7.5 Storage Precautions

When storing modules as spares for a long time, the following precautions are necessary.

- (1) The polarizer surface should not come in contact with any other object.
It is recommended that they be stored in the container in which they were shipped.
Temperature : 5 ~ 40 °C
- (2) Humidity : 35 ~ 75 %RH
- (3) Period : 6 months
- (4) Control of ventilation and temperature is necessary.
- (5) Please make sure to protect the product from strong light exposure, water or moisture.
Be careful for condensation.
- (6) Store in a polyethylene bag with sealed so as not to enter fresh air outside in it.
- (7) Do not store the LCD near organic solvents or corrosive gasses.
- (8) Please keep the Modules/OC/FOG at a circumstance shown below Fig.

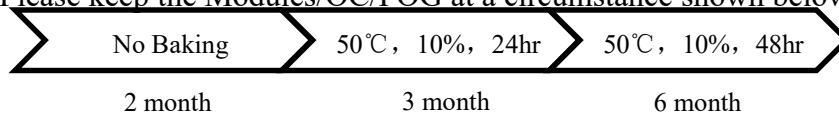

7.6 Precautions for Protection Film

- (1) Remove the protective film slowly, keeping the removing direction approximate 30-degree not vertical from panel surface, If possible, under ESD control device like ion blower, and the humidity of working room should be kept over 50%RH to reduce the risk of static charge.
- (2) In handling the LCD, wear non-charged material gloves. And the conducting wrist to the earth and the conducting shoes to the earth are necessary.

7.7 Appropriate Condition for Display

- (1) Normal operating condition
 - Temperature: 0 ~ 40°C
 - Operating Ambient Humidity : 10 ~ 90 %
 - Display pattern: dynamic pattern (Real display)
 - Suitable operating time: under 12 hours a day.
- (2) Special operating condition
If the product will be used in extreme conditions such as high temperature, humidity, display patterns or 7*24hrs operation time etc., It is strongly recommended to contact Wanty for Application engineering advice. Otherwise, its reliability and function may not be guaranteed.
- (3) Black image or moving image is strongly recommended as a screen save.

深圳市万天源光电有限公司
Shenzhen Wanty Photoelectric Co., Ltd

- (4) Lifetime in this spec. is guaranteed only when commercial display is used according to operating usages.
- (5) Please contact BOE in advance when you display the same pattern for a long time.
- (6) If the Module keeps displaying the same pattern for a long period of time, the image may be “sticked“ or “turn off” to the screen. To avoid image sticking, it is recommended to use a screen saver.
- (7) Do not exceed the absolute maximum rating value. (supply voltage variation, input voltage variation, variation in part contents and environmental temperature, and so on) Otherwise the Module may be damaged.
- (8) Dew drop atmosphere should be avoided.
- (9) The storage room should be equipped with a good ventilation facility and avoid to expose to corrosive gas, which has a temperature controlling system.
- (10) The LCD should be avoided to expose to corrosive gas for long time, the LCD may be affected by the gas as SO₂, H₂S etc.
- (11) When expose to drastic fluctuation of temperature (hot to cold or cold to hot), the LCD may be affected; Specifically, drastic temperature fluctuation from cold to hot, produces dew on the LCD's surface which may affect the operation of the polarizer and the LCD.
- (12) Response time will be extremely delayed at lower temperature than the operating temperature range and on the other hand at higher temperature LCD may turn black at temperature above its operational range. However those phenomena do not mean malfunction or out of order with the LCD. The LCD will revert to normal operation once the temperature returns to the recommended temperature range for normal operation

7.8 Others

A. LC Leak

- If the liquid crystal material leaks from the panel, it is recommended to wash the LC with acetone or ethanol and then burn it.
- In case of contact with hands, skin or clothes, it has to be washed away thoroughly with soap.
- If LC in mouth, mouth need to be washed, drink plenty of water to induce vomiting and follow medical advice.
- If LC touch eyes, eyes need to be washed with running water at least 15 minutes.

B. Rework

- When returning the module for repair or etc., Please pack the module not to be broken. We recommend to use the original shipping packages.

C. In order to prevent potential problems, flicker should be adjusted by optimizing the Vcom value in customer LCM Line (适用于Q/Single/OC出货产品)

8.0 Mechanical Drawing

