

深圳市万天源光电有限公司  
Shenzhen Wanty Photoelectric Co.,Ltd

产品规格书  
Specification

<b>PRODUCTCODE:</b>	<b>TY101IPF00R220</b>
<b>CUSTOMER NAME:</b>	

CUSTOMER APPROVED	PREPARE BY	CHECK BY	APPROVED BY
SUPPLIER APPROVED	PREPARE BY	CHECK BY	APPROVED BY

# 深圳市万天源光电有限公司

## Shenzhen Wanty Photoelectric Co.,Ltd

### 1. PHYSICAL DATA

Item	Contents	Unit
LCD type	TFT TRANSMISSIVE	---
Viewing direction	All	o'clock
Module size (W×H×T)	235 × 143 × 3.5	mm <sup>3</sup>
Active area(W×H)	222.72×125.28	mm <sup>2</sup>
Number of dots(W×H)	1024(RGB) × 600	dots
Pixel Pitch(H×V)	0.2175×0.2088	mm
Driver IC	EK79001	---
Colors	16.7M	---
Backlight Type	27 white leds 9.6V 180mA	---
Interface Type	RGB	---

### 2. BLOCK DIAGRAM

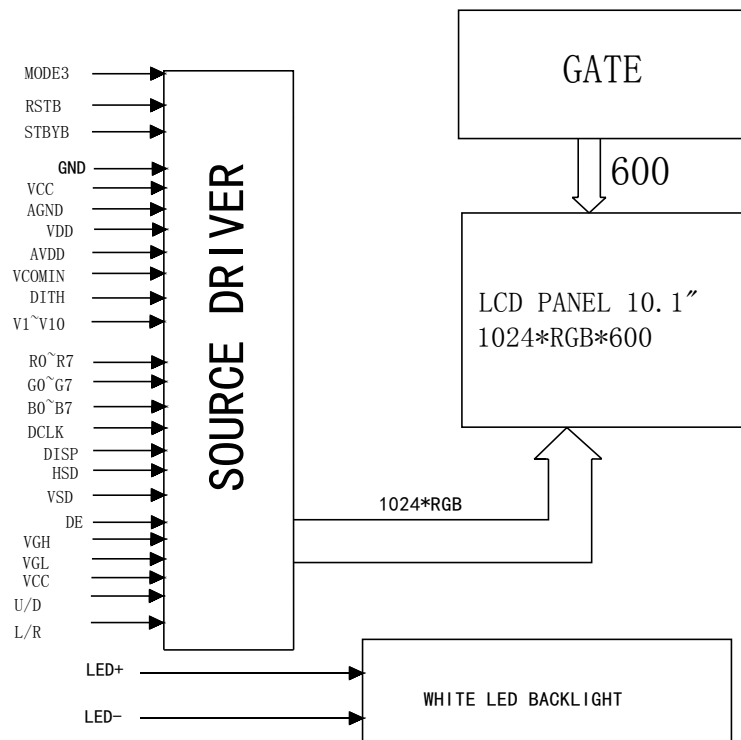

# 深圳市万天源光电有限公司

## Shenzhen Wanty Photoelectric Co.,Ltd

### 3. Mechanical Dimension

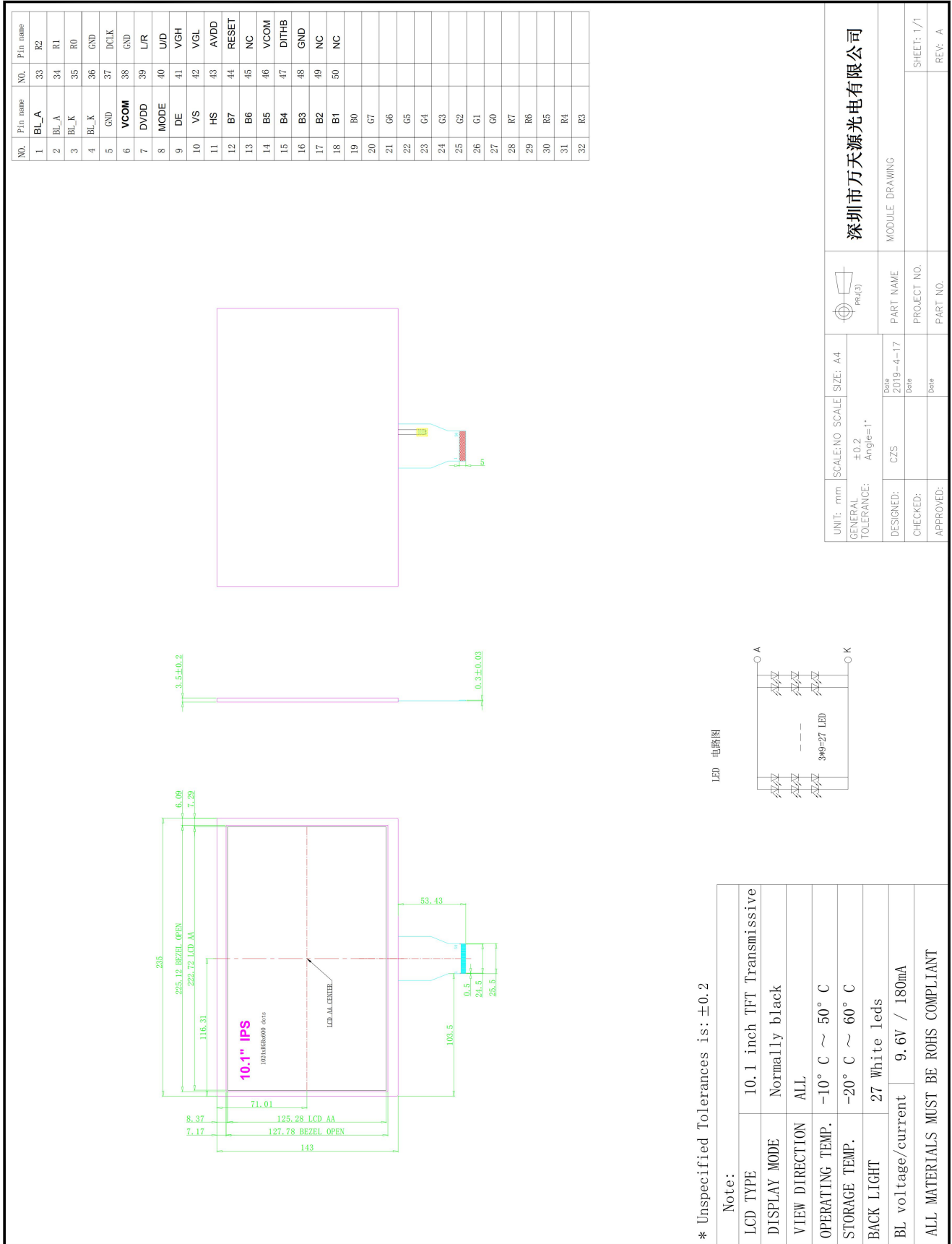

# 深圳市万天源光电有限公司

## Shenzhen Wanty Photoelectric Co.,Ltd

### 4. Pin Descriptions

Pin No.	Symbol	Functional
1	LED A	LED Anode
2	LED A	LED Anode
3	LED K	LED Cathode
4	LED K	LED Cathode
5	GND	Digital Ground
6	VCOM	For external VCOM DC input
7	DVDD	Digital Power
8	MODE	DE/SYNC mode select MODE=H: DE mode( normally pull high) MODE=L: HSD/VSD mode
9	DE	Data enable signal
10	VSYNC	Vertical sync input.Negative polarity
11	HSYNC	Horizontal sync input.Negative polarity
12~19	B7~B0	Blue data Input
20~27	G7~G0	Green data Input
28~35	R7~R0	Red data Input
36	GND	Digital Ground
37	DCLK	Clock input
38	GND	Digital Ground
39	L/R	Source right or left sequence control SHLR=H: right shift, Left → Right SHLR=L: left right, Right → Left
40	U/D	Gate up or down scan control UPDN=H: up shift, Down → Up UPDN=L: down shift, Up → Down
41	VGH	Positive Power for TFT
42	VGL	Negative Power for TFT
43	AVDD	Analog Power
44	RSTB	Global reset pin.Active low to enter reset state Suggest to connecting with an RC reset circuit for stability. Normally pull high. (RC circuit :R=10K $\Omega$ , C=1uF)
45	NC	Not connect
46	VCOM	For external VCOM DC input
47	DITHB	Dithering setting,DITH=0 enable internal dithering;DITH=1 disable internal dithering
48	GND	Digital Ground
49	NC	Not connect
50	NC	Not connect

# 深圳市万天源光电有限公司

## Shenzhen Wanty Photoelectric Co.,Ltd

---

### 5. OPERATION SPECIFICATION

#### 5.1 Absolute maximum ratings

Parameter	Symbol	Min	Max	Unit
Power supply1	V <sub>DD</sub>	-0.5	+3.96	V
Power supply2	A <sub>vdd</sub>	-0.5	+13.85	V
Operating temperature	T <sub>OPR</sub>	-10	50	°C
Storage temperature	T <sub>STG</sub>	-20	60	°C

#### 5.2 Input driver voltage

Parameter	Symbol	Value	Unit	Remarks
TFT Gate ON Voltage	V <sub>GH</sub>	21	V	
TFT Gate Off Voltage	V <sub>GL</sub>	-8	V	
Analog Power Supply Voltage	A <sub>VDD</sub>	9.6	V	
TFT Common Electrode Voltage	V <sub>COM</sub>	4.2	V	Note

Note: Please adjust V<sub>com</sub> to make the flicker level be minimum

# 深圳市万天源光电有限公司

## Shenzhen Wanty Photoelectric Co.,Ltd

### 6. DC ELECTRICAL CHARACTERISTICS

Parameter	Symbol	Condition	Min.	Typ.	Max.	Unit
Low level input voltage	Vil	For the digital circuit	0	-	0.3×VDD	V
High level input voltage	Vih	For the digital circuit	0.7×VDD	-	VDD	V
Input leakage current	Ii	For the digital circuit	-	-	±1	μA
High level output voltage	Voh	Ioh= -400 μA	VDD-0.4	-	-	V
Low level output voltage	Vol	Iol= +400 μA	-	-	GND+0.4	V
Pull low/high resistor	Ri	For the digital input pin @ VDD=3.3V	200K	250K	300K	ohm
Digital Operation current	Idd	Fclk=65 MHz, FLB=50KHz, VDD=3.3V	-	15	25	mA
Digital Stand-by current	Ist1	Clock and all functions are stopped	-	10	50	μA
Analog Operating Current	Idda	No load, Fclk=65MHz, FLB=50KHz @ AVDD=10V, V1=8V, V14=0.4V	-	10	12	mA
Analog Stand-by current	Ist2	No load, Clock and all functions are Stopped	-	10	50	μA
Input level of V1 ~ V7	Vref1	Gamma correction voltage input	0.4*AVDD	-	AVDD-0.1	V
Input level of V8 ~ V14	Vref2	Gamma correction voltage input	0.1	-	0.6*AVDD	V
Output Voltage deviation	Vod1	Vo = AVSS+0.1V ~ AVSS+0.5V and Vo = AVDD-0.5V ~ AVDD-0.1V	-	±20	±35	mV
Output Voltage deviation	Vod2	Vo = AVSS+0.5V ~ AVDD-0.5V	-	±15	±20	mV
Output Voltage Offset between Chips	Voc	Vo = AVSS+0.5V ~ AVDD-0.5V	-	-	±20	mV
Dynamic Range of Output	Vdr	SO1 ~ SO1536	0.1	-	AVDD-0.1	V
Sinking Current of Outputs	IOLy	SO1 ~ SO1536; Vo=0.1V v.s 1.0V , AVDD=13.5V	80	-	-	uA
Driving Current of Outputs	IOHy	SO1 ~ SO1536; Vo=13.4V v.s 12.5V , AVDD=13.5V	80	-	-	uA
Resistance of Gamma Table	Rg	Rn: Internal gamma resistor	0.7*Rn	1.0*Rn	1.3*Rn	ohm

# 深圳市万天源光电有限公司

## Shenzhen Wanty Photoelectric Co.,Ltd

### 7. Parallel RGB input timing table

DE mode					
Parameter	Symbol	Value			Unit
		Min.	Typ.	Max.	
DCLK frequency @Frame rate=60hz	fclk	40.8	51.2	67.2	Mhz
Horizontal display area	thd	1024			DCLK
HSYNC period time	th	1114	1344	1400	DCLK
HSYNC blanking	thb+thfp	90	320	376	DCLK
Vertical display area	tvd	600			H
VSYNC period time	tv	610	635	800	H
VSYNC blanking	tvb+tvfp	10	35	200	H

#### HV mode(1)

HV mode Horizontal input timing					
Parameter	Symbol	Value			Unit
		Min.	Typ.	Max.	
Horizontal display area	thd	1024			DCLK
DCLK frequency@ Frame rate=60hz	fclk	44.9	51.2	63	Mhz
1 Horizontal Line	th	1200	1344	1400	DCLK
HSYNC pulse width	thpw	Min.	1		
		Typ.	-		
		Max.	140		
HSYNC back porch	thbp	160	160	160	
HSYNC front porch	thfp	16	160	216	

#### HV mode(2)

Vertical input timing					
Parameter	Symbol	Value			Unit
		Min.	Typ.	Max.	
Vertical display area	tvd	600			H
VSYNC period time	tv	624	635	750	H
VSYNC pulse width	tpw	1	-	20	H
VSYNC back porch	tvb	23	23	23	H
VSYNC front porch	tvfp	1	12	127	H

# 深圳市万天源光电有限公司

## Shenzhen Wanty Photoelectric Co.,Ltd

### 8. AC Electrical Characteristics

Parameter	Symbol	Condition	Min.	Typ.	Max.	Unit
VDD Power On Slew rate	TPOR	From 0V to 90% VDD	1	-	20	ms
RST pulse width	TRST	DCLK = 65MHz	50	-	-	us
DCLK cycle time	Tcph	-	14	-	-	ns
DCLK pulse duty	Tcwh	-	40	50	60	%
VSD setup time	Tvst	-	5	-	-	ns
VSD hold time	Tvhd	-	5	-	-	ns
HSD setup time	Thst	-	5	-	-	ns
HSD hold time	Thhd	-	5	-	-	ns
Data set-up time	Tdsu	D0[7:0], D1[7:0], D2[7:0] to DCLK	5	-	-	ns
Data hold time	Tdhd	D0[7:0], D1[7:0], D2[7:0] to DCLK	5	-	-	ns
DE setup time	Tesu	-	5	-	-	ns
DE hold time	Tehd	-	5	-	-	ns
Output stable time	Tsst	Dual gate	-	-	3	us

### 9. Backlight Characteristic

Item	Symbol	Min	Typical	Max	Unit
LED module Forward voltage	$V_{LED}$	--	9.6	--	V
LED module current	$I_{LED}$	--	180	--	mA
L/G Surface Luminance ★1	$L_s$	--	tbd	--	mcd
LCM Surface brightness uniform ★2	$L_D$	80	--	--	%

★ 1 Test condition is:

- (a) Center point on active area.
- (b) Best Contrast.

★2 Uniform measure condition:

- (1) Measure 9 point. Measure location show below;
- (2)  $Uniform = (Min. \text{ brightness} / Max. \text{ brightness}) * 100\%$
- (3) Best Contrast.

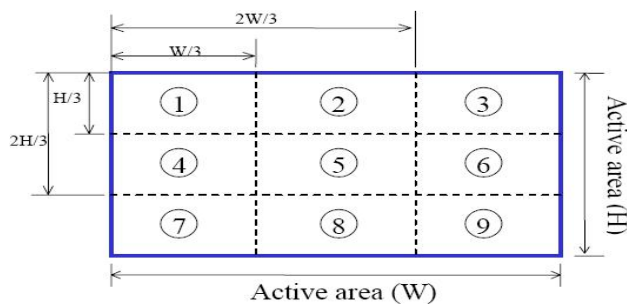

# 深圳市万天源光电有限公司

## Shenzhen Wanty Photoelectric Co.,Ltd

### 10. Electro-optical Characteristics

Parameter		Symbol	Condition	Min.	Typ.	Max.	Unit	Remark			
Viewing Angle range	Horizontal	Θ3	CR > 10	-	85	-	Deg.				
		Θ9		-	85	-	Deg.				
	Vertical	Θ12		-	85	-	Deg.				
		Θ6		-	85	-	Deg.				
Luminance Contrast ratio		CR		-	800	-					
Cell Transmittance		Tr		4.8	5.8	-	%				
White Chromaticity		xw	Θ = 0	TYP. - 0.03	0.307	TYP. + 0.03					
		yw			0.338						
Red	Rx	0.605									
	Ry	0.336									
Green	Gx	0.297									
	Gy	0.552									
Blue	Bx	0.139									
	By	0.132									
Color Gamut (C light)							-	50	-	%	
Response Time (Rising + Falling)		TRT			Ta= 25 °C Θ = 0		-	30	40	ms	

### 11. Reliability

#### 11.1 Mtbf

The LCD module shall be designed to meet a minimum MTBF value of 50000 hours with normal

#### 11.2 Test condition

N O.	ITEM	CONDITION	CRITERION
1	High Temperature Non-Operating Test	60°C*120Hrs	No Defect Of Operational Function In Room Temperature Are Allowable
2	Low Temperature Non-Operating Test	-20°C*120Hrs	
3	High Temperature/Humidity Non Operating Test	60°C*75%RH*240Hrs	
4	High Temperature Operating Test	50°C*120Hrs	
5	Low Temperature Operating Test	-10°C*120Hrs	
6	Thermal Shock Test	-10 °C (30Min) - 50 °C (30Min) *10CYCLES	

# 深圳市万天源光电有限公司

## Shenzhen Wanty Photoelectric Co.,Ltd

Notes:

1. Judgments should be made after exposure in room temperature for two hours.
2. The distill water is used for the high temperature/humidity test.
3. The sample above is individually for every reliability tests condition.

## 12. Inspection standards

1. AQL(Acceptable Quality Level)

AQL of major and minor defect.

	MAJOR DEFECT	MINOR DEFECT
AQL	0.65	1.5

### 2. Basic conditions for inspection

The LCM face to us, in normal environment, the lux is  $1000 \pm 200$ . (Darkroom's lux:  $100 \pm 50$ ), About an angle of incidence  $30^\circ$ , a distance of 30 cm with an angle of  $45 \pm 10^\circ$  to check the products without uncovering the film!

(As shown below)

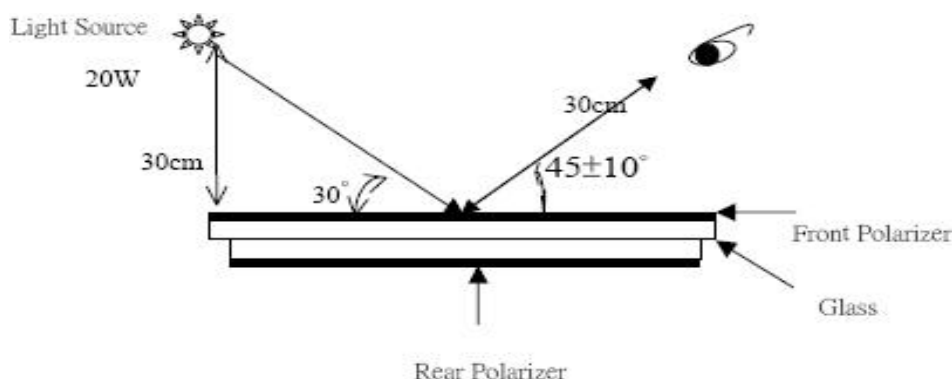

### 3. Inspection item and criteria

#### 3.1 LCD appearance defect(View area)

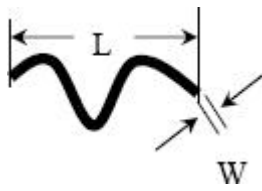
NO	Defect item	Criteria		Remark
1	Fiber 、 glass cratch、 polarizer scratch/folded (minor defect)	Specification	Allowable	note1:L: Length, W: Width note2: disregard if out of AA 
		$W \leq 0.03\text{mm}$	disregard	
		$0.03\text{mm} < W \leq 0.05\text{mm};$ $L \leq 3.0\text{mm}$	2	
		$0.05\text{mm} < W \leq 0.1\text{mm};$ $L \leq 3.0\text{mm}$	1	
		$W > 0.1\text{mm}; L > 3.0\text{mm}$	0	
2	Polarizer bubble、 concave and convex (minor defect)	$\phi \leq 0.2\text{mm}$	disregard	note1: $\phi = (L+W)/2$ , L: Length, W :Width note2:disregard if out of AA
		$0.2\text{mm} < \phi \leq 0.3\text{mm}$	2	
		$0.3\text{mm} < \phi \leq 0.5\text{mm}$	1	

# 深圳市万天源光电有限公司

## Shenzhen Wanty Photoelectric Co.,Ltd

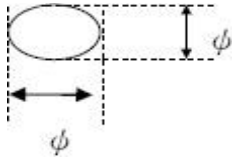
		$0.5\text{mm} < \phi$	0	
3	Black dots、dirty dots、 impurities、eye winker (minor defect)	$\phi \leq 0.15\text{mm}$	disregard	note2:disregard if out of AA 
		$0.15\text{mm} < \phi \leq 0.25\text{mm}$	2	
		$0.25\text{mm} < \phi \leq 0.3\text{mm}$	1	
		$0.3\text{mm} < \phi$	0	
4	Polarizer prick (minor defect)	$\phi \leq 0.1\text{mm}$	disregard	note1: $\phi = (L+W)/2$ , L=Length, W=Width note2:the distance between two dots>5mm
		$0.1\text{mm} < \phi \leq 0.25\text{mm}$	3	
		$\phi > 0.25\text{mm}$	0	

### 3.2 Electrical criteria

NO	Defect item	Criteria	Remark	
1	No display (major defect)	No display 【Reject】		
2	Missing line (major defect)	Missing line 【Reject】		
3	Seg-com light and dark (major defect)	Seg-com light and dark 【Reject】	ND filter 2% test	
4	No display in immobility (major defect)	No display in immobility 【Reject】		
5	Flicker of Pattern (major defect)	Flicker of Pattern 【Reject】		
6	Mura (major defect)	ND filter 2%test		
7	Over current (major defect)	Over current 【Reject】		
8	Voltage out of specification (major defect)	Voltage out of specification 【Reject】		
9	Pattern blur, error code (major defect)	Pattern blur, error code 【Reject】		
10	Dark light, Flicker (major defect)	Dark light, Flicker 【Reject】		
11	Black/white dots、 Dirty dots、 eye winker (major defect)	Specification	Allowable	Note1:disregard if out of AA
		$\phi \leq 0.15\text{mm}$	disregard	
		$0.15\text{mm} < \phi \leq 0.25\text{mm}$	2	
		$0.25\text{mm} < \phi \leq 0.3\text{mm}$	1	
		$0.3\text{mm} < \phi$	0	

# 深圳市万天源光电有限公司

## Shenzhen Wanty Photoelectric Co.,Ltd

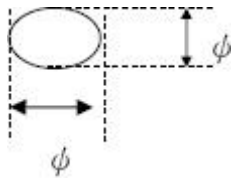
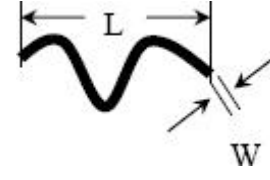
				
12	Fiber, glass crutch, Polarizer scratch/folded (major defect)	$W \leq 0.03\text{mm}$	disregard	Note1:L: Length, W: Width Note2: disregard if out of AA 
		$0.03\text{mm} < W \leq 0.05\text{mm}$ $L \leq 3.0\text{mm}$	2	
		$0.05\text{mm} < W \leq 0.1\text{mm}$ $L \leq 3.0\text{mm}$	1	
		$W > 0.1\text{mm}; L > 3.0\text{mm}$	0	

### 13. Precautions for using LCD modules.

#### 13.1 Safety

- (1) Do not swallow any liquid crystal, even if there is no proof that liquid crystal is poisonous.
- (2) If the LCD panel breaks, be careful not to get liquid crystal to touch your skin.
- (3) If skin is exposed to liquid crystal, wash the area thoroughly with alcohol or soap.

#### 13.2 Storage Conditions

- (4) Store the panel or module in a dark place where the temperature is  $23 \pm 5^\circ\text{C}$  and the humidity is below  $45 \pm 20\% \text{RH}$ .
- (5) Store in anti-static electricity container.
- (6) Store in clean environment, free from dust, active gas, and solvent.
- (7) Do not place the module near organics solvents or corrosive gases.
- (8) Do not crush, shake, or jolt the module.

#### 13.3 Handling Precautions

- (9) Avoid static electricity, which can damage the CMOS LSI.
- (10) The polarizing plate of the display is very fragile, please handle it very carefully.
- (11) Do not give external shock.
- (12) Do not apply excessive force on the surface.
- (13) Do not wipe the polarizing plate with a dry cloth, as it may easily scratch the surface of plate.
- (14) Do not operate it above the absolute maximum rating.
- (15) Do not remove the panel or frame from the module.

#### 13.4 Warranty

The period is within twelve months since the date of shipping out under normal using and storage conditions.