



ONation Corporation

TFT COLOR LCD MODULE

MODEL: OT215BFWDLV-H0
(Complied with RoHS)

FULL HD
LVDS interface

Version: P0.1

Customer : _____
Approved By : _____
Date: _____

ONATION		
APPROVAL	CHECKER	PREPARE
Ian	Ian	Josh

All information is subject to change without notice.
Please confirm the sales representative before starting to design your system

CONTENTS

NO.	ITEM	PAGE
1	RECORD OF REVISION	0-1
2	MECHANICAL SPECIFICATIONS	1
3	OUTLINE DIMENSIONS	2
4	INTERFACE PIN CONNECTION	3~4
5	BLOCK DIAGRAM	5
6	ABSOLUTE MAXIMUM RATINGS	6
7	ELECTRICAL CHARACTERISTICS	7~8
8	OPTICAL CHARACTERISTICS	9~11
9	TIMING SPECIFICATIONS	12~14
10	RELIABILITY TEST	15
11	LCM INSPECTION STANDARD	16
12	PACKAGE INFORMATION	16
13	PRECAUTIONS FOR USE	17

2.MECHANICAL SPECIFICATIONS

(1)	Number Of Dots (Dots)	1920(R.G.B) X 1080
(2)	Module Size(mm)	495.6 (W) X 292.2(H) X 19.56(D)
(3)	Active Area(mm)	476.64(H) X 268.11(V)
(4)	Dot Pitch(mm)	0.24825(H) X 0.24825(V)
(5)	LCD / Polarizer Model	VA mode, Normally/Black,Anti-Glare
(6)	LED Backlight Color	White
(7)	Viewing Direction	Wide Viewing Angle Horizontal : Right side 89°(typ.), Left side 89°(typ.) Vertical : Up side 89°(typ.), Down side 89°(typ.)
(8)	Color Configuration	R.G.B Vertical Stripe
(9)	Module Weight(g)	1700±5g

4. INTERFACE PIN CONNECTION

4.1 LCM PANEL DRIVING SECTION

Type Part Number : P-TWO AL230F-A0G1D-P or STM MSCKT2407P30HB

Mating Housing Part Number : FI-X30HL(Locked Type)

PIN NO.	SYMBOL	FUNCTION	REMARKS
1	RxOIN0-	Negative LVDS differential data input (Odd data)	
2	RxOIN0+	Positive LVDS differential data input (Odd data)	
3	RxOIN1-	Negative LVDS differential data input (Odd data)	
4	RxOIN1+	Positive LVDS differential data input (Odd data)	
5	RxOIN2-	Negative LVDS differential data input(Odd data)	
6	RxOIN2+	Positive LVDS differential data input(Odd data)	
7	GND	Power Ground	
8	RxOCLK-	Negative LVDS differential clock input (Odd clock)	
9	RxOCLK+	Positive LVDS differential clock input (Odd clock)	
10	RxOIN3-	Negative LVDS differential data input (Odd data)	
11	RxOIN3+	Positive LVDS differential data input (Odd data)	
12	RxEIN0-	Negative LVDS differential data input (Even data)	
13	RxEIN0+	Positive LVDS differential data input (Even data)	
14	GND	Power Ground	
15	RxEIN1-	Negative LVDS differential data input (Even data)	
16	RxEIN1+	Positive LVDS differential data input (Even data)	
17	GND	Power Ground	
18	RxEIN2-	Negative LVDS differential data input (Even data)	
19	RxEIN2+	Positive LVDS differential data input (Even data)	
20	RxECLK-	Negative LVDS differential clock input (Even clock)	
21	RxECLK+	Positive LVDS differential clock input (Even clock)	
22	RxEIN3-	Negative LVDS differential data input (Even data)	
23	RxEIN3+	Positive LVDS differential data input (Even data)	
24	GND	Power Ground	
25	NC	Do not connect	
26	NC	Do not connect	
27	NC	Do not connect	
28	VDD	Power	
29	VDD	Power	
30	VDD	Power	

4.2 BACKLIGHT UNIT

Connector : 3808K-Q06N-03R or Equivalen

PIN NO.	SYMBOL	FUNCTION	REMARKS
1	VLED	Converter input voltage	
2	VLED	Converter input voltage	
3	EN	Enable pin (3.3V-ON,0V-OFF)	
4	ADJ	Dimming(PWM)	
5	GND	Converter ground Ground	
6	GND	Converter ground Ground	

5. BLOCK DIAGRAM

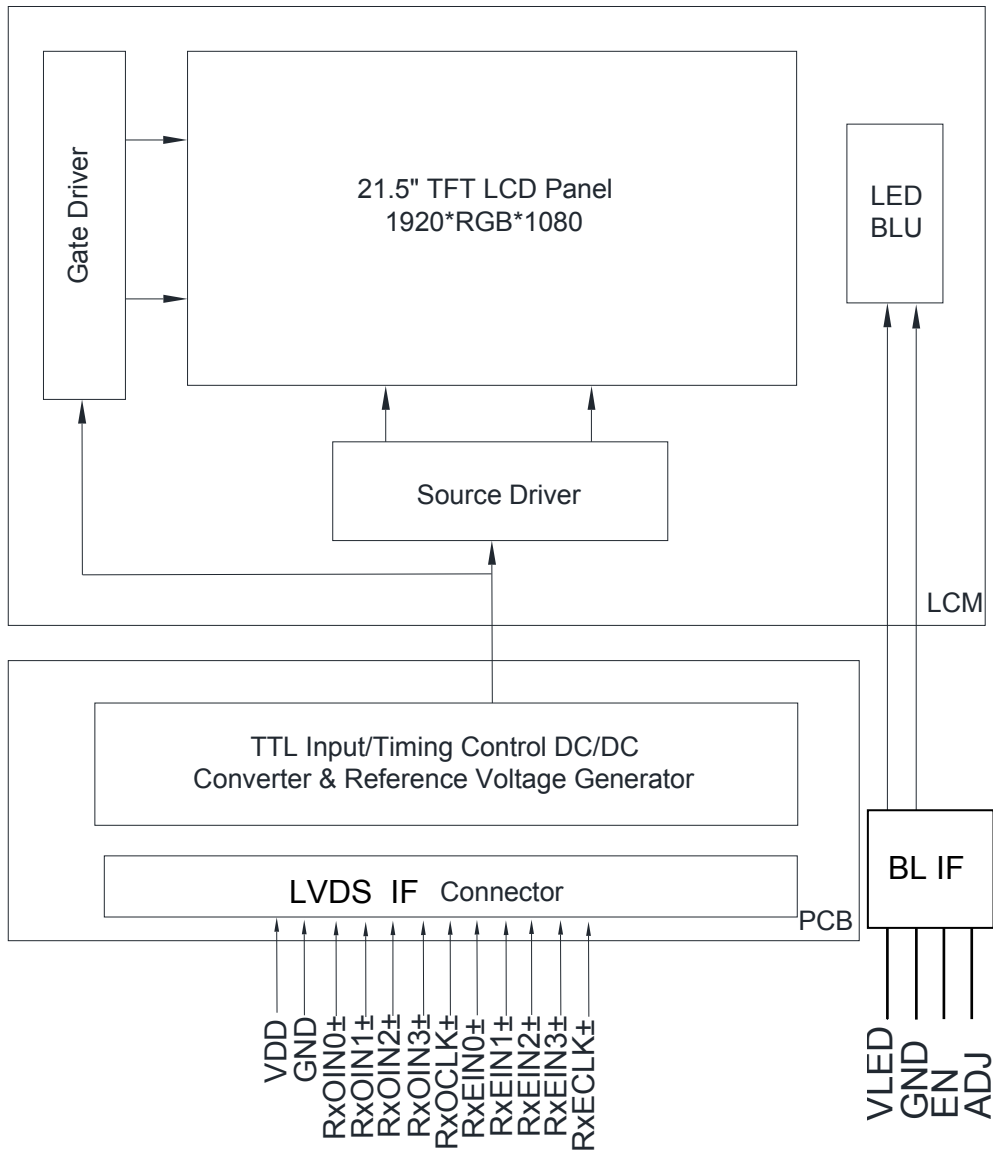

6.ABSOLUTE MAXIMUM RATINGS

6.1 ELECTRICAL ABSOLUTE MAXIMUM RATINGS

ITEM	SYMBOL	MIN.	MAX.	UNIT	REMARK
Logic/ LCD drive voltage	VDD	GND-0.3	6	V	

Note: The absolute maximum rating values of this product not allowed to be exceeded at any times. Should be module be used with any of absolute maximum ratings exceeded. The characteristics of the module may not be recovered, or in an extreme case, the module may be permanently destroyed.

6.2 ENVIRONMENTAL ABSOLUTE MAXIMUM RATINGS

ITEM	OPERATING		STORAGE		REMARK
	MIN	MAX	MIN	MAX	
Ambient Temperature(°C)	0	(50)	-20	60	
Humidity(% RH)	5	90	5	90	

Note 1 : The response time will become lower when operated at low temperature.

Note 2 : Background color changes slightly depending on ambient temperature.

Note 3 : $T_a \leq 50^\circ\text{C}$: 80%RH max , without condensation.

$T_a > 50^\circ\text{C}$: Absolute humidity shall be less than the value of 80%RH at 50°C without conclensation.

7.ELECTRICAL CHARACTERISTICS

7.1 ELECTRICAL CHARACTERISTICS OF LCD

Ta=25°C

ITEM	SYMBOL	MIN.	TYP.	MAX.	UNIT	REMARK
Logic/ LCD Drive Voltage	VDD	4.5	5	5.5	V	
Input current	IDD	-	0.62	0.74	A	VDD=5V,All black pattern. At 60Hz
			0.7	0.84	A	VDD=5V,All black pattern. At 75Hz
VDD power	PDD	-	3.1	3.7	W	VDD=5V,All black pattern. At 60Hz
			3.5	4.2	W	VDD=5V,All black pattern. At 75Hz
Inrush current	IRush	-	-	3	A	Note1
Allowable Logic/LCD Drive Ripple Voltage	VDDrp	-	-	500	mV(p-p)	VDD=5V,All black pattern. At 75Hz

Note1: Inrush Current measurement:

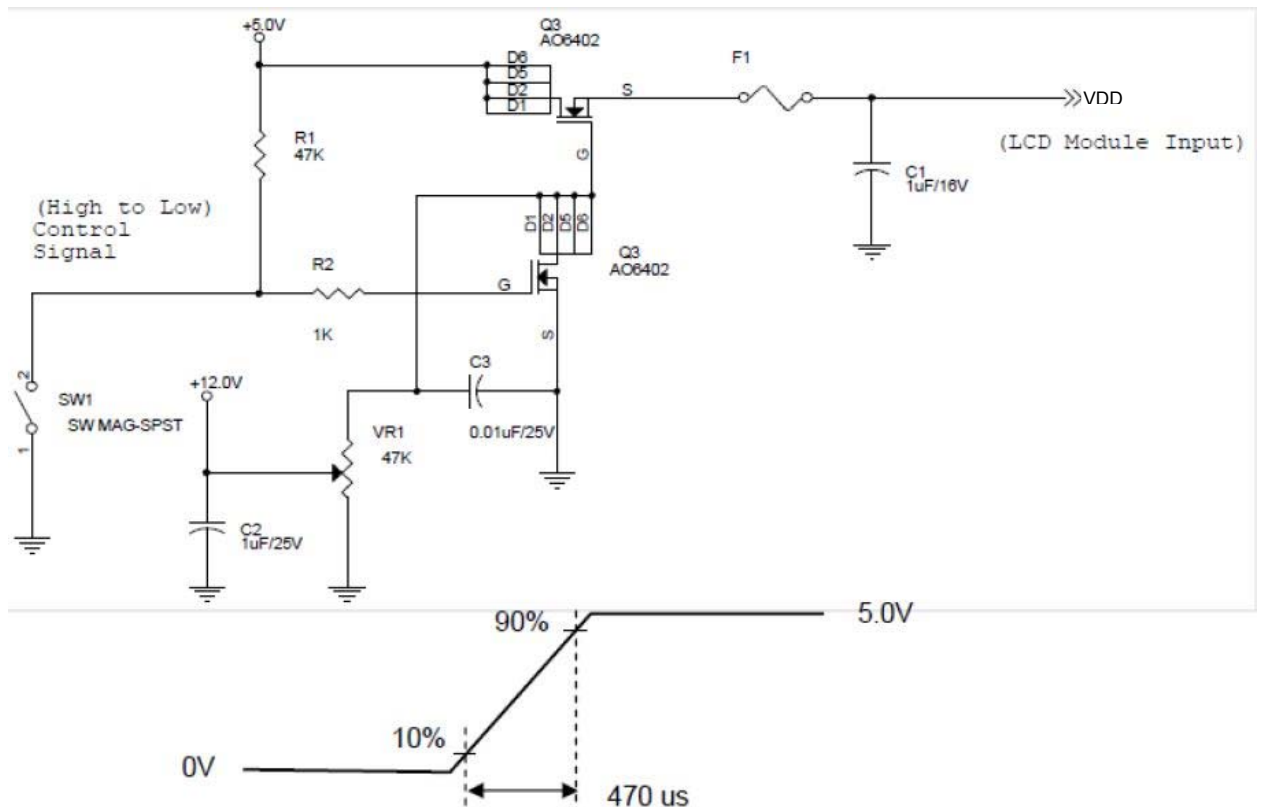

The duration of VDD rising time : 470us

7.2 SIGNAL ELECTRICAL CHARACTERISTICS

7.2.1 DC Characteristics

ITEM	SYMBOL	MIN.	TYP.	MAX.	UNIT	REMARK
LVDS Differential Input High Threshold	V_{TH}	-	-	+100	mV	$V_{CM}=1.2V$,
LVDS Differential Input Low Threshold	V_{TH}	-100	-	-	mV	$V_{CM}=1.2V$,
LVDS Differential Input Voltage	$ V_{ID} $	100	-	600	mV	
LVDS Common Mode Voltage	V_{CM}	+1.0	+1.2	+1.5	V	$V_{TH}-V_{TL}=200mV$

LVDS Signal Waveform:

Use RxOCLK- & RxOCLK+ as example

Single-End

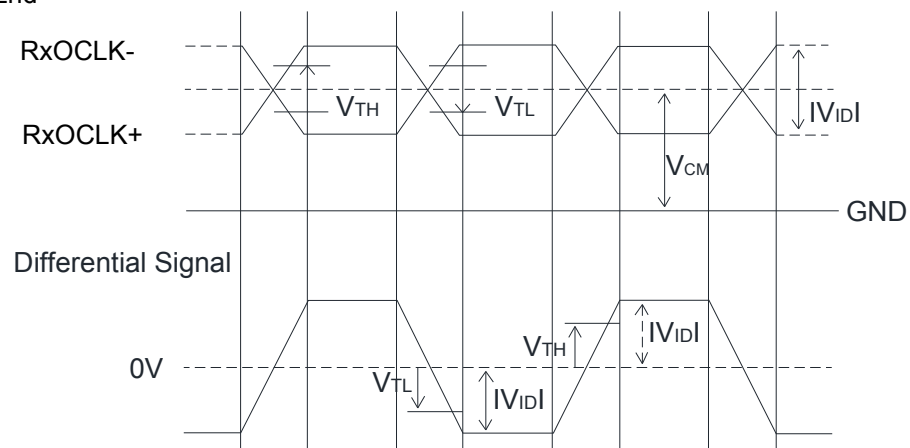

7.3 BACKLIGHT UNIT

$T_a=25^{\circ}C$

ITEM	SYMBOL	MIN.	TYP.	MAX.	UNIT	REMARK
LED Driving Voltage	V_{LED}	10.8	12.0	12.6	V	
	I_{LED}	-	1700	1900	mA	
PWM Input Low Threshold	V_{PWM_LO}	0.75	-	-	V	
PWM Input High Threshold	V_{PWM_HI}	-	-	1.25	V	
PWM Control Duty Ratio	-	0	-	100	%	
PWM Control Frequency	f_{PWM}	200	-	2000	Hz	
EN Voltage	EN	3.0	3.3	3.6	V	

8.OPTICAL CHARACTERISTICS

Ta=25°C

ITEM	SYMBOL	CONDITIONS	MIN.	TYP.	MAX.	UNIT	REMARK	
Contrast Ratio	CR	Viewing Normal Angle $\Theta_x = \Theta_y = 0^\circ$	TBD	TBD	-	-	Note (1)	
Response Time	TR+TF		-	18	36	ms	Note (2)	
Chromaticity	White		Wx	(0.18)	(0.23)	(0.28)	-	Note (4)
			Wy	(0.21)	(0.26)	(0.31)	-	
Viewing Angle	Hor.	Θ_{x+}	Horizontal(Right) CR=10	75	89	-	Deg. Note (3)	
		Θ_{x-}	(Left)	75	89			
	Ver.	Θ_{y+}	Vertical (Up) CR=10	75	89	-		
		Θ_{y-}	(Down)	75	89			
Luminance	L	PWM=100%	300	400	-	cd/m2	-	
Luminance uniformity	YU		60	70	-	%	Note (5)	

*Note (1) Definition of Contrast Ratio (CR):

The contrast ratio can be calculated by the following expression.

$$\text{Contrast Ratio (CR)} = L63 / L0$$

L63: Luminance of gray level 63

L 0: Luminance of gray level 0

$$CR = CR (5)$$

CR (X) is corresponding to the Contrast Ratio of the point X at Figure in Note (5).

*Note (2) Definition of Response Time (TR, TF):

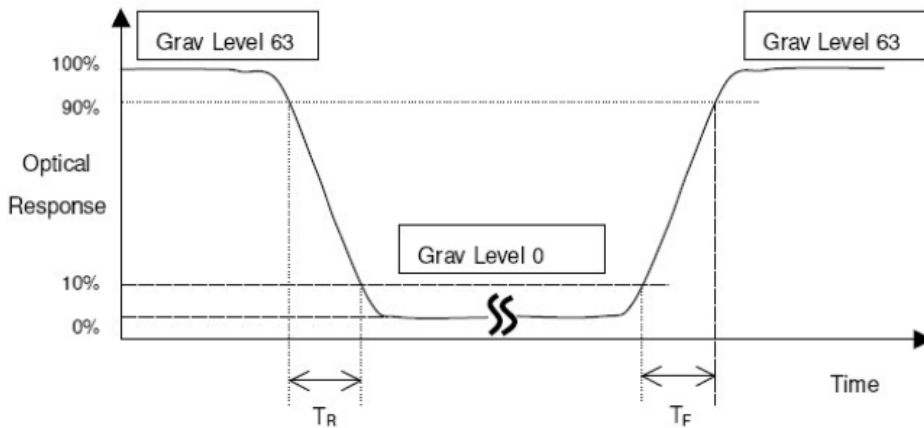

*Note(3) Definition of Viewing Angle

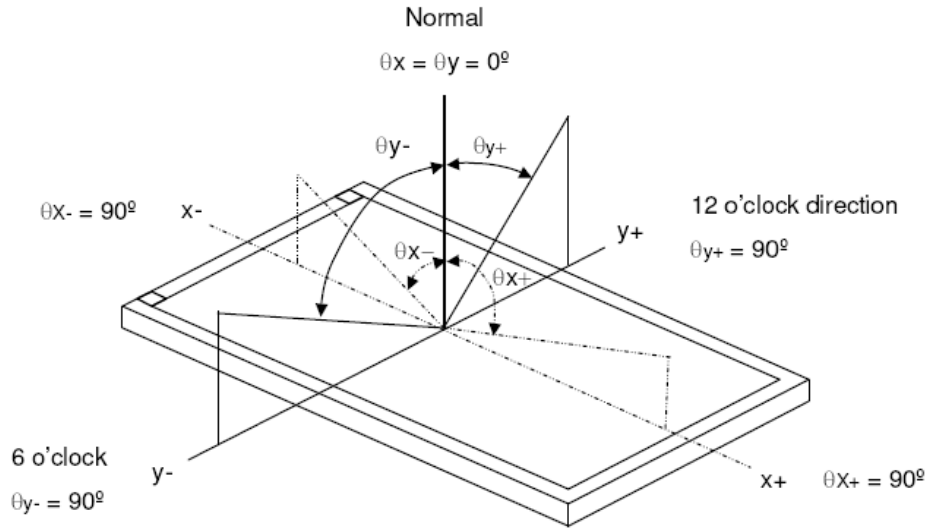

*|

The LCD module should be stabilized at a given temperature for 20 minutes to avoid abrupt temperature change during measuring. In order to stabilize the luminance, the measurement should be executed after lighting Backlight for 20 minutes in a windless room.

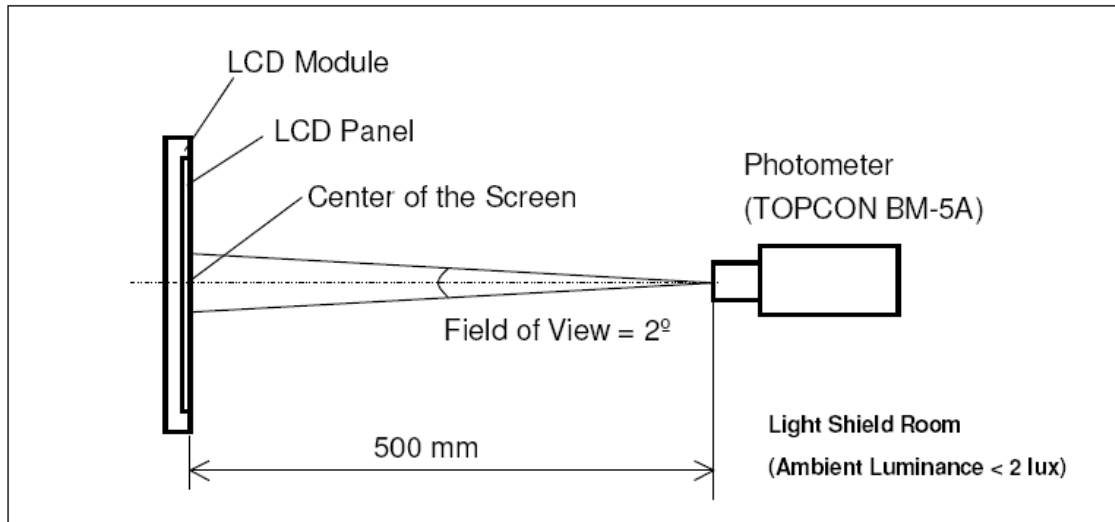

*Note (5)

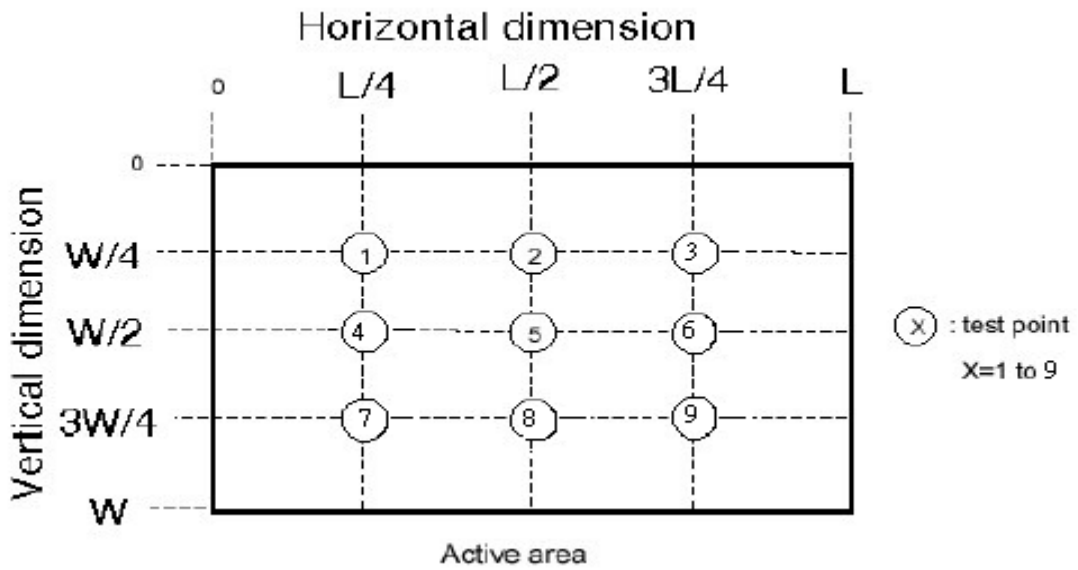

$$\left(1 - \frac{\text{MAX Luminance} - \text{Average Luminance}}{\text{Average Luminance}} \right) \times 100 \% = \text{YU}$$

9. TIMING SPECIFICATIONS

9.1 THE INPUT DATA FORMAT

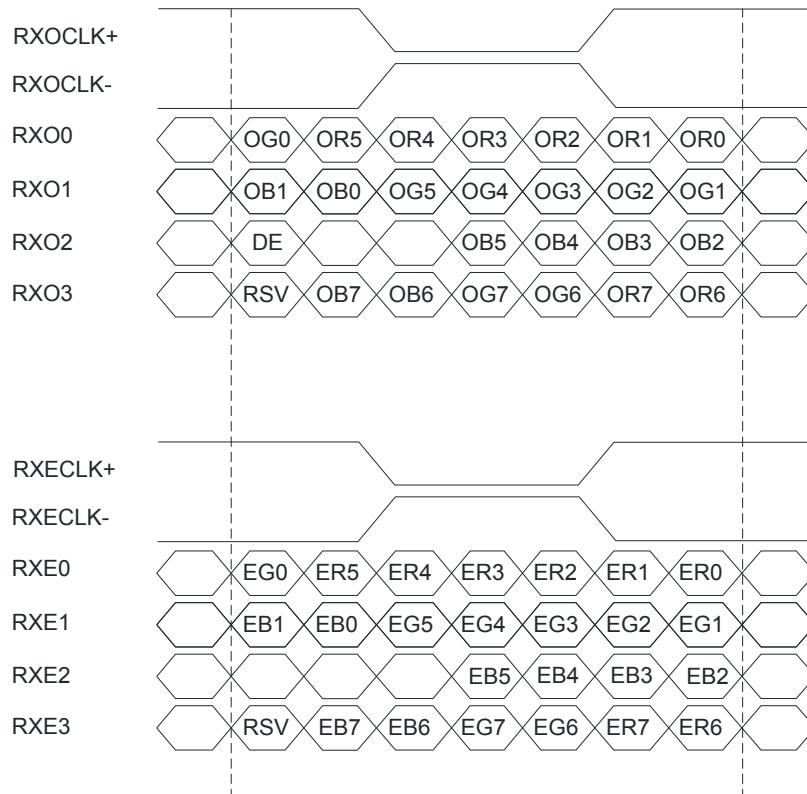

8 Bit Color Bit Order			
MSB	R7	G7	B7
	R6	G6	B6
	R5	G5	B5
	R4	G4	B4
	R3	G3	B3
	R2	G2	B2
	R1	G1	B1
LSB	R0	G0	B0

Note1: R/G/B data 7:MSB. R/G/B data 0:LSB

“O”=“First Pixel Data”

“E”=“Second Pixel Data”

9.2 TIMING CHARACTERISTICS

It only support DE mode, and the input timing are shown as the following table

ITEM		SYMBOL	MIN.	TYP.	MAX.	UNIT	REMARK
Vertical section	Period	Tv	1092	1130	1818	Th	
	Active	Tdisp(v)	1080	1080	1080	Th	
	Blanking	Tblk(v)	12	50	738	Th	
	Frequency	Fv	50	60	76	Hz	
Horizontal section	Period	Th	1034	1050	1100	Tclk	
	Active	Tdisp(h)	960	960	960	Tclk	
	Blanking	Tblk(h)	74	90	140	Tclk	
	Frequency	Fh	55	68	91	KHz	Note 1
LVDS Clock	Period	Tclk	10.6	14.0	17.7	ns	1/Fclk
	Frequency	Fclk	56.5	71.2	94	MHz	Note 2

Note 1 :The equation is listed as following. Please don't exceed the above recommended value.

$Fh(\text{Min.})=Fclk(\text{Min.})/Th(\text{Min.})$; $Fh(\text{Typ.})=Fclk(\text{Typ.})/Th(\text{Typ.})$; $Fh(\text{Max.})=Fclk(\text{Max.})/Th(\text{Min.})$;

Note 2 :The equation is listed as following. Please don't exceed the above recommended value.

$Fclk(\text{Min.})=Fv(\text{Min.}) \times Th(\text{Min.}) \times Tv(\text{Min.})$; $Fclk(\text{Typ.})=Fv(\text{Typ.}) \times Th(\text{Typ.}) \times Tv(\text{Typ.})$;

$Fclk(\text{Max.})=Fv(\text{Max.}) \times Th(\text{Typ.}) \times Tv(\text{Typ.})$;

9.3 TIMING DIAGRAM

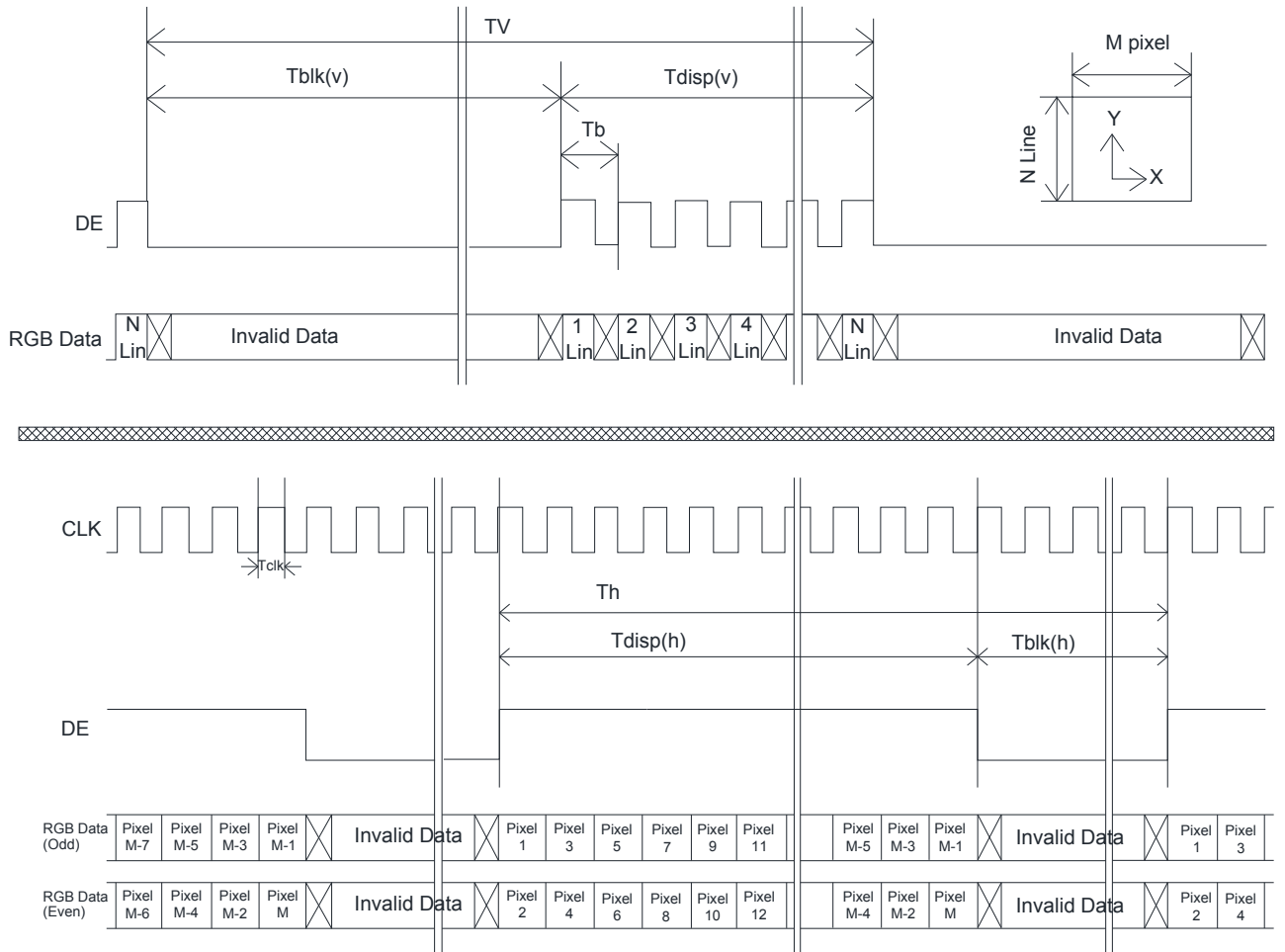

9.4 POWER ON/OFF SEQUENCE

VDD Power and lamp on/off sequence is as follows. Interface signals are also shown in the chart. Signals from any system shall be Hi-Z state or low level when VDD is off.

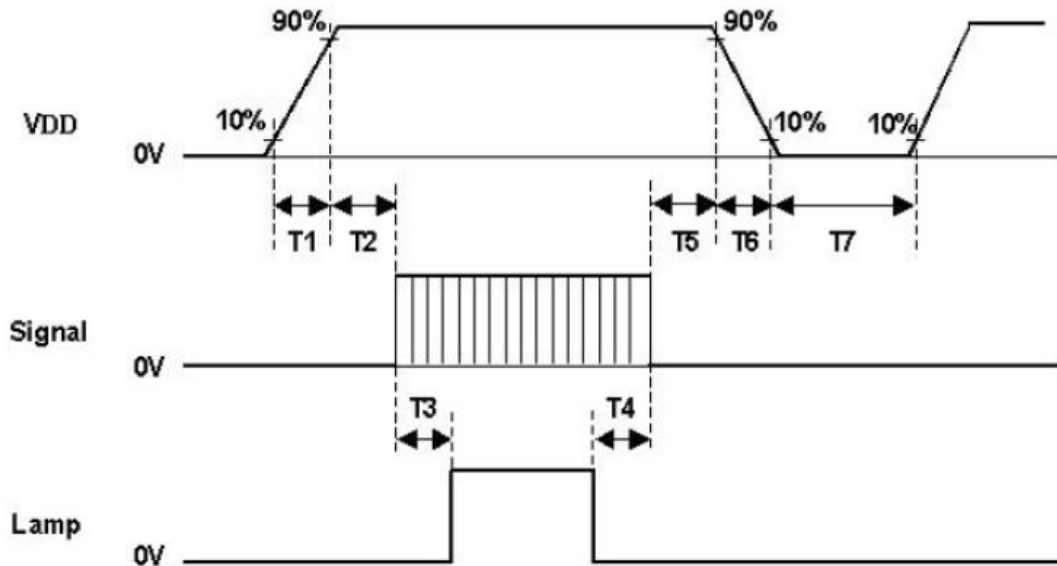

ITEM	MIN.	TYP.	MAX.	UNIT	REMARK
T1	0.5	-	10	[ms]	
T2	0	-	50	[ms]	
T3	500	-	-	[ms]	
T4	100	-	-	[ms]	
T5	0	-	50	[ms]	Note 1, Note 2
T6	0	-	100	[ms]	Note 2
T7	1000	-	-	[ms]	

Note 1 : Recommend setting T5=0ms to avoid electronic noise when VDD is off.

Note 2 : During T5 and T6 period , please keep the level of input LVDS signals with Hi-Z state

10. RELIABILITY TEST

ENVIRONMENTAL TEST				
NO.	ITEM	CONDITIONS	TIME PERIOD	REMARK
1	High Temperature Storage	60°C	240HRS	Note1,4
2	Low Temperature Storage	-20°C	240HRS	Note1,4
3	High Temperature Humidity Storage	50°C,80%RH	240HRS	Note4
4	High Temperature Operation	(50°C)	(240HRS)	Note2,4
5	Low Temperature Operation	0°C	240HRS	Note1,4
6	Temperature Cycle	-20°C→60°C (30min) (30min)	50CYCLE	Note4

Note1 : Ta is the ambient temperature of samples.

Note2 : Ts is the temperature of panel's surface.

Note3 : In the standard condition, there shall be no practical problem that may affect the display function. After the reliability test, the product only guarantees operation, but don't guarantee all of the cosmetic specification.

Note4 : Before cosmetic and function test, the product must have enough recovery time, at least 2 hours at room temperature.

11. LCM INSPECTION STANDARD

Inspection specifications refer ONation Corporation LCM INSPECTION STANDARD Document.
Document Number : TBD

12. PACKAGE INFORMATION

LCM Model	LCM Qty. in the box	Inner Box Size (mm)	Weight	REMARK
OT215BFWDLV-H0	TBD	TBD	TBD	

13. PRECAUTIONS FOR USE

13.1 SAFETY

- (1) Do not swallow any liquid crystal, even if there is no proof that liquid crystal is poisonous.
- (2) If the LCD panel breaks, be careful not to get liquid crystal to touch your skin.
- (3) If skin is exposed to liquid crystal, wash the area thoroughly with alcohol or soap.

13.2 STORAGE CONDITIONS

- (1) Store the panel or module in a dark place where the temperature is $23\pm 5^{\circ}\text{C}$ and the humidity is below $50\pm 20\% \text{RH}$.
- (2) Store in anti-static electricity container.
- (3) Store in clean environment, free from dust, active gas, and solvent.
- (4) Do not place the module near organics solvents or corrosive gases.
- (5) Do not crush, shake, or jolt the module.

13.3 HANDLING PRECAUTIONS

- (1) Avoid static electricity which can damage the CMOS LSI.
- (2) The polarizing plate of the display is very fragile. So, please handle it very carefully.
- (3) Do not give external shock.
- (4) Do not apply excessive force on the surface.
- (5) Do not wipe the polarizing plate with a dry cloth, as it may easily scratch the Surface of plate.
- (6) Do not use ketonics solvent & Aromatic solvent, use with a soft cloth soaked with a cleaning naphtha solvent.
- (7) Do not operate it above the absolute maximum rating.
- (8) Do not remove the panel or frame from the module.
- (9) When the module is assembled, it should be attached to the system firmly, Be careful not to twist and bend the module.
- (10) Wipe off water droplets or oil immediately . If you leave the droplets for a long time, staining and discoloration may occur.
- (11) If the liquid crystal material leaks from the panel, it should be kept away from the eyes or mouth. In case of contact with hands, legs or clothes, it must be washed away thoroughly with soap.

13.4 WARRANTY

- (1) Acceptance inspection period
The period is within one month after the arrival of contracted commodity at the buyer's factory site.
- (2) Applicable warrant period
The period is within 12 months since the date of shipping out under normal using and storage conditions.