

CUSTOMER APPROVE

SPECIFICATION
FOR
DOUBLE LIN TFT-LCD MODULE

Edition : Preliminary spec 1.0

Date of issue : 2022-07-03

Product No. : M236HJJ-P02

APPROVED	CHECKED	PREPARED
Wei Yan	ZhongCai Liang	YongHeng Jia

Revision History

Date	Rev.	Page	Old Description	New Description	Remark
2022-07-03	1.0	All	The specification was first issued		

1. GENERAL DESCRIPTION

1.1 OVERVIEW

The M236HJJ-P02 is a 23.6" TFT Liquid Crystal Display MNT open cell with driver ICs and a 30-pins-2ch-LVDS circuit board. The product supports 1920 x 1080 Full HD mode and can display up to 16.7M colors. The backlight unit is not built in.

1.2 GENERAL SPECIFICATIONS

ITEMS	Unit	SPECIFICATIONS
Screen Diagonal	[mm]	23.6
Active Area	[mm]	521.28(H) × 293.22 (V)
Pixels H x V	-	1920(H) × 1080(V)
Pixels Pitch	[mm]	0.2715(H) × RGB× 0.2715(V)
Pixels Arrangement	-	Pixels RGB Vertical stripe
White Luminance(Center)	[cd/m ²]	300 (Typ.)
Contrast Ratio	-	3000 (Typ.)
Response Time	[msec]	10ms (Typ.on/off)
Viewing Angle	[degree]	89/89/89/89
Outline Dimension	[mm]	544.8(H) x 320.5(V) x 10.47(D) (Typ.)
Electrical Interface	-	Dual Channel LVDS
Support Color		16.7M colors
Surface Treatment		Haze:25% 3H
Temperature Range Operating Storage(Shipping)	[oC] [oC]	0 to +50°C -20 to+60°C

2. MECHANICAL SPECIFICATIONS

Item	Min.	Typ.	Max.	Unit	Note
Weight		TBD		g	
I/F connector mounting position	The mounting inclination of the connector makes the screen center within ±0.5mm as the horizontal.				(2)

Note (1) Please refer to the attached drawings for more information of front and back outline dimensions.

(2) Connector mounting position

(3) Please refer to sec.3.1 for more information of power consumption.



3. ABSOLUTE MAXIMUM RATINGS

3.1 ABSOLUTE RATINGS OF ENVIRONMENT

Item	Symbol	Value		Unit	Note
		Min.	Max.		
Storage Temperature	TST	-20	60	°C	(1)
Operating Ambient Temperature	TOP	0	50	°C	(1), (2)

Note (1)

(a) 90 %RH Max.

(b) Wet-bulb temperature should be 39 °C Max.

(c) No condensation.

Note (2) The temperature of panel surface should be 0 °C min. and 60 °C max.

Panel surface temperature should be 0 min. and 65 max under Vcc=12.0V, Input fr =60Hz, typical LED string current, 25 ambient temperature, and no humidity control. Any condition of ambient operating temperature, the surface of active area should be keeping not higher than 65 .

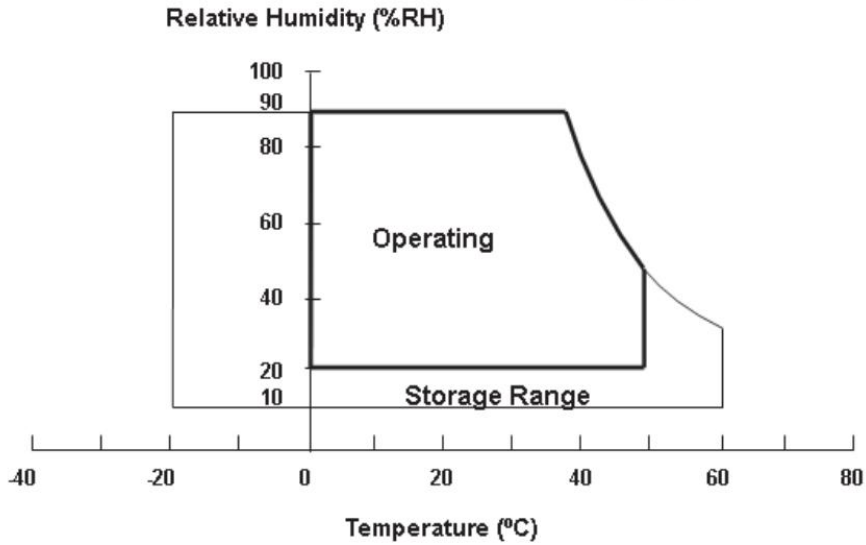

3.2 ELECTRICAL ABSOLUTE RATINGS

3.2.1 TFT LCD OPEN CELL

Item	Symbol	Value		Unit	Note
		Min.	Max.		
Power Supply Voltage	VCCS	-0.3	6.0	V	(1)
Logic Input Voltage	V _{IN}	-0.3	3.6	V	

Note (1) Permanent damage to the device may occur if maximum values are exceeded. Function operation should be restricted to the conditions described under Normal Operating Conditions.

3.3 ABSOLUTE RATINGS OF ENVIRONMENT (OPEN CELL)

High temperature or humidity may reduce the performance of panel. Please store LCD panel within the specified storage conditions.

Storage Condition: With packing.

Storage temperature range: 25±5 °C.

Storage humidity range: 50±10%RH.

Shelf life: 30days ELECTRICAL SPECIFICATIONS

4. ELECTRICAL SPECIFICATIONS

4.1 FUNCTION BLOCK DIAGRAM

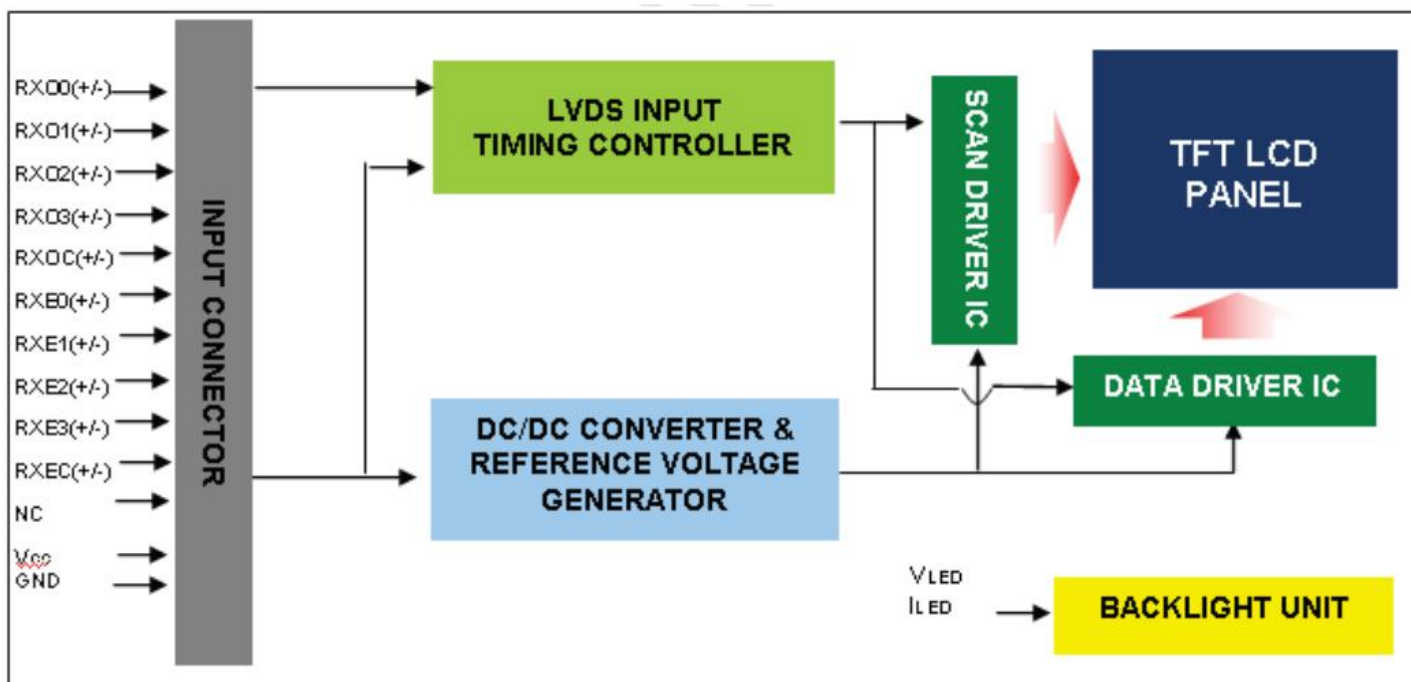

4.2 INTERFACE CONNECTIONS

Pin	Name	Description
1	RX00-	Negative LVDS differential data input. Channel O0 (odd)
2	RX00+	Positive LVDS differential data input. Channel O0 (odd)
3	RX01-	Negative LVDS differential data input. Channel O1 (odd)
4	RX01+	Positive LVDS differential data input. Channel O1 (odd)
5	RX02-	Negative LVDS differential data input. Channel O2 (odd)
6	RX02+	Positive LVDS differential data input. Channel O2 (odd)
7	GND	Ground
8	RXOC-	Negative LVDS differential clock input. (odd)
9	RXOC+	Positive LVDS differential clock input. (odd)
10	RX03-	Negative LVDS differential data input. Channel O3(odd)
11	RX03+	Positive LVDS differential data input. Channel O3 (odd)
12	RXE0-	Negative LVDS differential data input. Channel E0 (even)
13	RXE0+	Positive LVDS differential data input. Channel E0 (even)
14	GND	Ground
15	RXE1-	Negative LVDS differential data input. Channel E1 (even)
16	RXE1+	Positive LVDS differential data input. Channel E1 (even)
17	GND	Ground
18	RXE2-	Negative LVDS differential data input. Channel E2 (even)
19	RXE2+	Positive LVDS differential data input. Channel E2 (even)
20	RXEC-	Negative LVDS differential clock input. (even)
21	RXEC+	Positive LVDS differential clock input. (even)
22	RXE3-	Negative LVDS differential data input. Channel E3 (even)
23	RXE3+	Positive LVDS differential data input. Channel E3 (even)
24	GND	Ground
25	NC	For LCD internal use only, Do not connect
26	SCL	I2C clock (for auto Vcom)
27	SDA	I2C data (for auto Vcom)
28	VCC	+5.0V power supply
29	VCC	+5.0V power supply
30	VCC	+5.0V power supply

*Notice: There would be compatible issues if not using the indicated connectors in the matching list.

Note (1) The first pixel is odd.

Note (2) Input signal of even and odd clock should be the same timing.

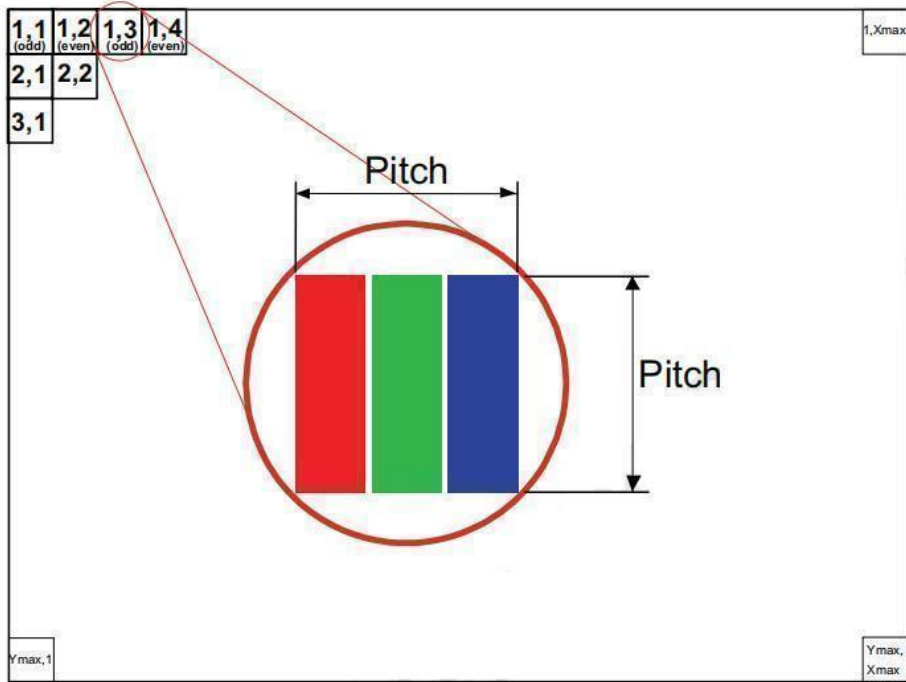

4.3 ELECTRICAL CHARACTERISTICS

4.3.1 LCD ELECTRONICS SPECIFICATION

Parameter		Symbol	Value			Unit	Note
			Min.	Typ.	Max.		
Power Supply Voltage		V _{CC}	4.5	5.0	5.5	V	
Ripple Voltage		V _{RP}			300	mV	-
Rush Current		I _{RUSH}			3	A	(2)
Power Supply Current	White			1.18	1.4	A	(3)a
	Black			0.83	0.97	A	(3)b
	Vertical Stripe			1.18	1.4	A	(3)c
Power Consumption		PLCD		5.7	7	Watt	(4)
LVDS interface	Differential Input Voltage	V _{ID}	100	-	600	mV	
	Common Input Voltage	V _{CM}	1.0	1.2	1.4	V	
	Differential Input High Threshold Voltage	V _{TH}		-	0.1	V	
	Differential Input Low Threshold Voltage	V _{TL}	-0.1	-		V	

Note (1) The ambient temperature is $T_a = 25 \pm 2$ °C.

Note (2) Measurement Conditions:

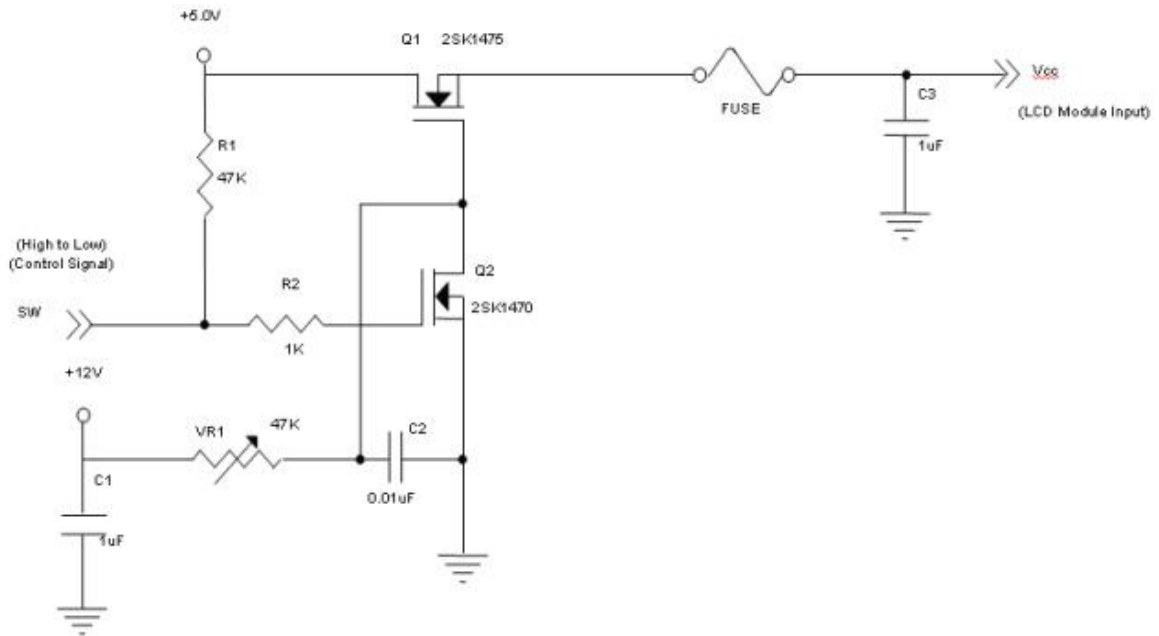

Vcc rising time is 470μs

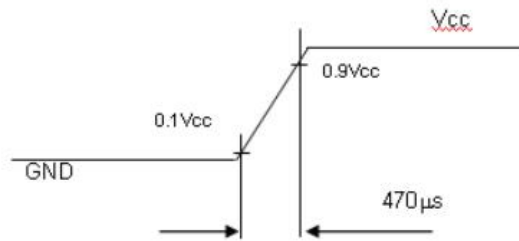

Note (3) The specified power supply current is under the conditions at $V_{cc} = 12.0\text{ V}$, $T_a = 25 \pm 2\text{ }^\circ\text{C}$, $F_r = 75\text{ Hz}$, whereas a power dissipation check pattern below is displayed.

a. White Pattern



Active Area

b. Black Pattern



Active Area

c. Vertical Stripe Pattern

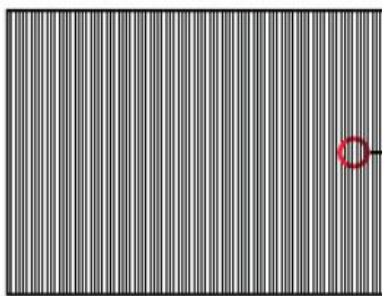

Active Area

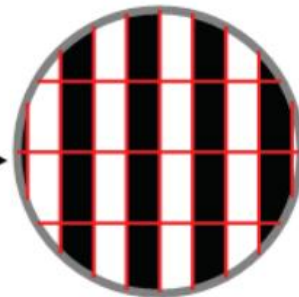

Note (4) The power consumption is specified at the pattern with the maximum current.

Note (5) The LVDS input characteristics are as follows:

4.4.2 COLOR DATA INPUT ASSIGNMENT

The brightness of each primary color (red, green and blue) is based on the 8-bit gray scale data input for the color.

The higher the binary input, the brighter the color. The table below provides the assignment of color versus data input.

Color		Data Signal																							
		RED								GREEN								BLUE							
		R7	R6	R5	R4	R3	R2	R1	R0	G7	G6	G5	G4	G3	G2	G1	G0	B7	B6	B5	B4	B3	B2	B1	B0
Basic Color	Black	0	0	0	0	0	0	0	0	0	0	0	0	0	0	0	0	0	0	0	0	0	0	0	0
	Red	1	1	1	1	1	1	1	1	0	0	0	0	0	0	0	0	0	0	0	0	0	0	0	0
	Green	0	0	0	0	0	0	0	0	1	1	1	1	1	1	1	1	0	0	0	0	0	0	0	0
	Cyan	0	0	0	0	0	0	0	0	1	1	1	1	1	1	1	1	1	1	1	1	1	1	1	1
	Magenta	1	1	1	1	1	1	1	1	0	0	0	0	0	0	0	0	1	1	1	1	1	1	1	1
	Blue	0	0	0	0	0	0	0	0	0	0	0	0	0	0	0	0	1	1	1	1	1	1	1	1
	Yellow	1	1	1	1	1	1	1	1	1	1	1	1	1	1	1	1	0	0	0	0	0	0	0	0
	White	1	1	1	1	1	1	1	1	1	1	1	1	1	1	1	1	1	1	1	1	1	1	1	1
Gray Scale of Red	Red(0) / Dark	0	0	0	0	0	0	0	0	0	0	0	0	0	0	0	0	0	0	0	0	0	0	0	
	Red(1)	0	0	0	0	0	0	0	1	0	0	0	0	0	0	0	0	0	0	0	0	0	0	0	
	Red(2)	0	0	0	0	0	0	1	0	0	0	0	0	0	0	0	0	0	0	0	0	0	0	0	
	△	↑								↑								↑							
	▽	↓								↓								↓							
	Red(253)	1	1	1	1	1	1	0	1	0	0	0	0	0	0	0	0	0	0	0	0	0	0	0	0
	Red(254)	1	1	1	1	1	1	1	0	0	0	0	0	0	0	0	0	0	0	0	0	0	0	0	0
	Red(255)	1	1	1	1	1	1	1	1	0	0	0	0	0	0	0	0	0	0	0	0	0	0	0	0
Gray Scale of Green	Green(0) /	0	0	0	0	0	0	0	0	0	0	0	0	0	0	0	0	0	0	0	0	0	0	0	
	Green(1)	0	0	0	0	0	0	0	0	0	0	0	0	0	0	0	1	0	0	0	0	0	0	0	
	Green(2)	0	0	0	0	0	0	0	0	0	0	0	0	0	0	1	0	0	0	0	0	0	0	0	
	△	↑								↑								↑							
	▽	↓								↓								↓							
	Green(253)	0	0	0	0	0	0	0	0	1	1	1	1	1	1	0	1	0	0	0	0	0	0	0	0
	Green(254)	0	0	0	0	0	0	0	0	1	1	1	1	1	1	1	0	0	0	0	0	0	0	0	0
	Green(255)	0	0	0	0	0	0	0	0	1	1	1	1	1	1	1	1	0	0	0	0	0	0	0	0
Gray Scale of Blue	Blue(0) / Dark	0	0	0	0	0	0	0	0	0	0	0	0	0	0	0	0	0	0	0	0	0	0	0	
	Blue(1)	0	0	0	0	0	0	0	0	0	0	0	0	0	0	0	0	0	0	0	0	0	0	1	
	Blue(2)	0	0	0	0	0	0	0	0	0	0	0	0	0	0	0	0	0	0	0	0	0	0	1	
	△	↑								↑								↑							
	▽	↓								↓								↓							
	Blue(253)	0	0	0	0	0	0	0	0	0	0	0	0	0	0	0	0	1	1	1	1	1	1	0	1
	Blue(254)	0	0	0	0	0	0	0	0	0	0	0	0	0	0	0	0	1	1	1	1	1	1	1	0
	Blue(255)	0	0	0	0	0	0	0	0	0	0	0	0	0	0	0	0	1	1	1	1	1	1	1	1

Note (1) 0: Low Level Voltage, 1: High Level Voltage

4.5 DISPLAY TIMING SPECIFICATIONS

The input signal timing specifications are shown as the following table and timing diagram.

Signal	Item	Symbol	Min.	Typ.	Max.	Unit	Note
LVDS Clock	Frequency	Fc	58.27	74.25	97.98	MHz	-
	Period	Tc		13.47		ns	
	Input cycle to cycle jitter	Trcl	-0.02*Tc	-	0.02*Tc	ns	(1)
	Input Clock to data skew	TLVCCS	-0.02*Tc	-	0.02*Tc	ps	(2)
	Spread spectrum modulation range	Fckin_mod	0.97*Fc	-	1.03*Fc	MHz	(3)
	Spread spectrum modulation frequency	FSSM	-	-	100	KHz	
Vertical Display Term	Frame Rate	Fr	50	60	63	Hz	Tv=Tvd+Tvb
	Total	Tv	1115	1125	1736	Th	
	Active Display	Tvd	1080	1080	1080	Th	
	Blank	Tvb	TV-Tvb	TV-Tvb	TV-Tvb	Th	
Horizontal Display Term	Total	Th	1050	1100	1150	Tc	Th=Thd+Thb
	Active Display	Thd	960	960	960	Tc	
	Blank	Thb	Th-Thd	Th-Thd	Th-Thd	Tc	

Note: Because this module is operated by DE only mode, Hsync and Vsync input signals are ignored.
INPUT SIGNAL TIMING DIAGRAM

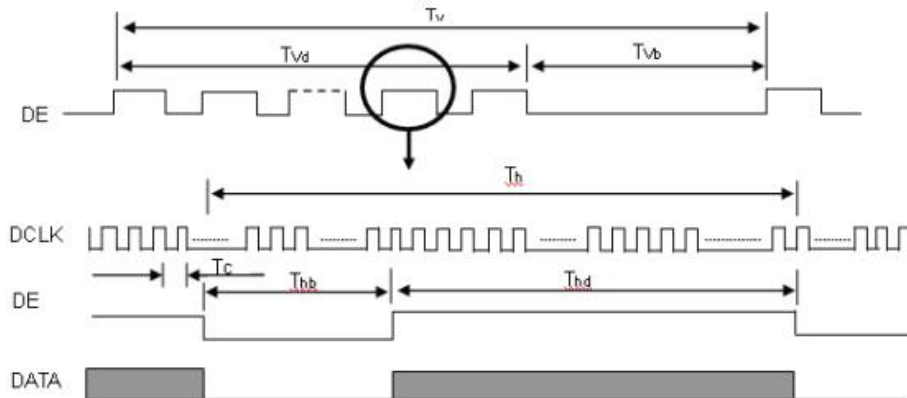

Note (1) The input clock cycle-to-cycle jitter is defined as below figures. $Trcl = |T1 - T2|$

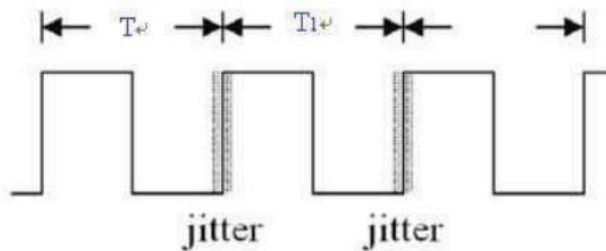

Note (2) Input Clock to data skew is defined as below figures.

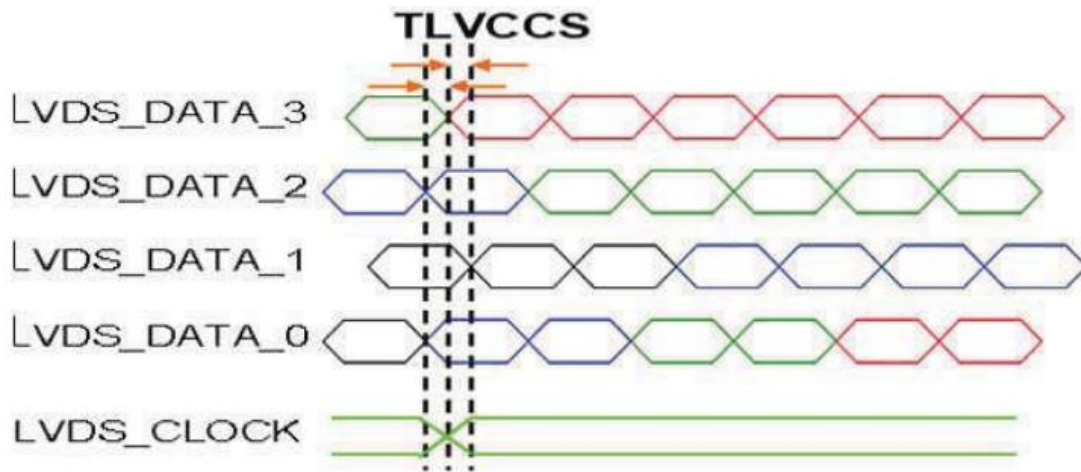

Note (3) The SSCG (Spread spectrum clock generator) is defined as below figures.

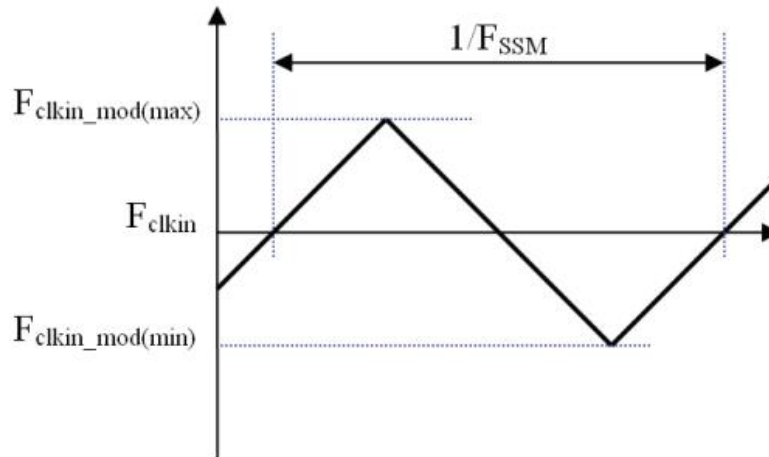

Note (4) The DCLK range at last line of V-blank should be set in 0 to Hdisplay/2

4.6 POWER ON/OFF SEQUENCE

The power sequence specifications are shown as the following table and diagram.

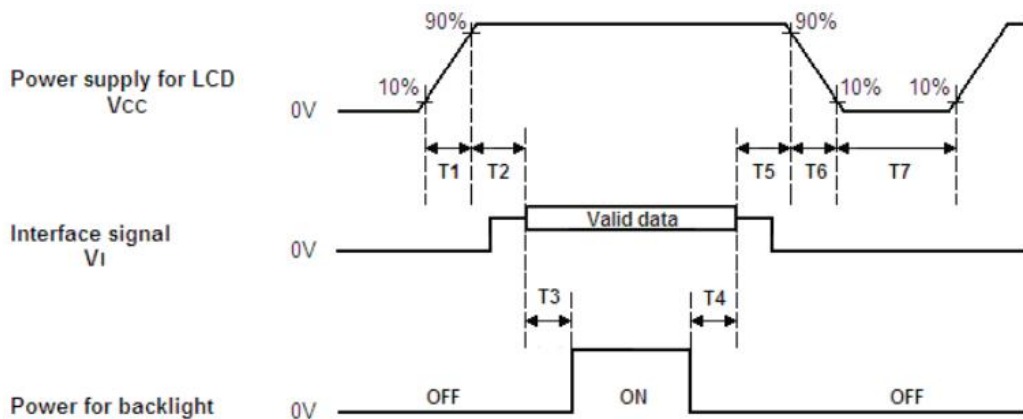

Timing Specifications:

Parameters	Values			Units
	Min	Typ.	Max	
T1	0.5	-	10	ms
T2	0	30	50	ms
T3	450	-	-	ms
T4	100	250	-	ms
T5	0	20	50	ms
T6	0.1	-	100	ms
T7	1000	-	-	ms

- Note (1) The supply voltage of the external system for the module input should be the same as the definition of Vcc.
 Note (2) When the backlight turns on before the LCD operation of the LCD turns off, the display may momentarily become abnormal screen.
 Note (3) In case of VCC = off level, please keep the level of input signals on the low or keep a high impedance.
 Note (4) T7 should be measured after the module has been fully discharged between power off and on period.
 Note (5) Interface signal shall not be kept at high impedance when the power is on.
 Note (6) INX won't take any responsibility for the products which are damaged by the customers not following the Power Sequence.
 Note (7) There might be slight electronic noise when LCD is turned off (even backlight unit is also off). To avoid this symptom, we suggest "Vcc falling timing" to follow "t6 spec".

5. OPTICAL CHARACTERISTICS

5.1 TEST CONDITIONS

Item	Symbol	Value	Unit
Ambient Temperature	Ta	25±2	oC
Ambient Humidity	Ha	50±10	%RH
Supply Voltage	VCC	5	V
Input Signal	According to typical value in "3. ELECTRICAL CHARACTERISTICS"		
LED Light Bar Input Current Per Input Pin	IPIN	95	mA
PWM Duty Ratio	D	100	%
LED Light Bar Test Converter	INX R373B0000U000		

5.2 OPTICAL SPECIFICATIONS

The relative measurement methods of optical characteristics are shown in 5.2. The following items should be measured under the test conditions described in 5.1 and stable environment shown in Note (7).

Item		Symbol	Condition	Min.	Typ.	Max.	Unit	Note					
Color Chromaticity (CIE 1931)	Red	Rx	$\theta_x=0^\circ, \theta_y=0^\circ$ CS-2000 R=G=B=255 Gray scale	Typ - 0.03	(0.639)	Typ + 0.03	-	(1),(7)					
		Ry			(0.344)								
	Green	Gx			(0.303)								
		Gy			(0.649)								
	Blue	Bx			(0.142)								
		By			(0.074)								
	White	Wx			(0.302)								
		Wy			(0.372)								
	Center Transmittance	T%								(4.6)		%	(1), (6)
	Contrast Ratio	CR							2000	3000	-	-	(1), (3)
Response Time	Gray to Gray	T _{GIG_AVE_}	$\theta_x=0^\circ, \theta_y=0^\circ$	-	10	16	ms	(4-1), (4-2)					
Viewing Angle	Horizontal	$\theta_x- +\theta_x+$	CR ≥10	160	178	-	Deg	(1), (2)					
Viewing Angle	Vertical	$\theta_y- +\theta_y+$		160	178	-							

Note (1) Light source is the BLU (M236HJJ-L30), which is supplied by innolux, and driving voltages are based on suitable gamma voltages. W, R, G, B are with signal input. SPEC is judged by innolux's golden sample.

Note (2) Definition of Viewing Angle (θ_x, θ_y):

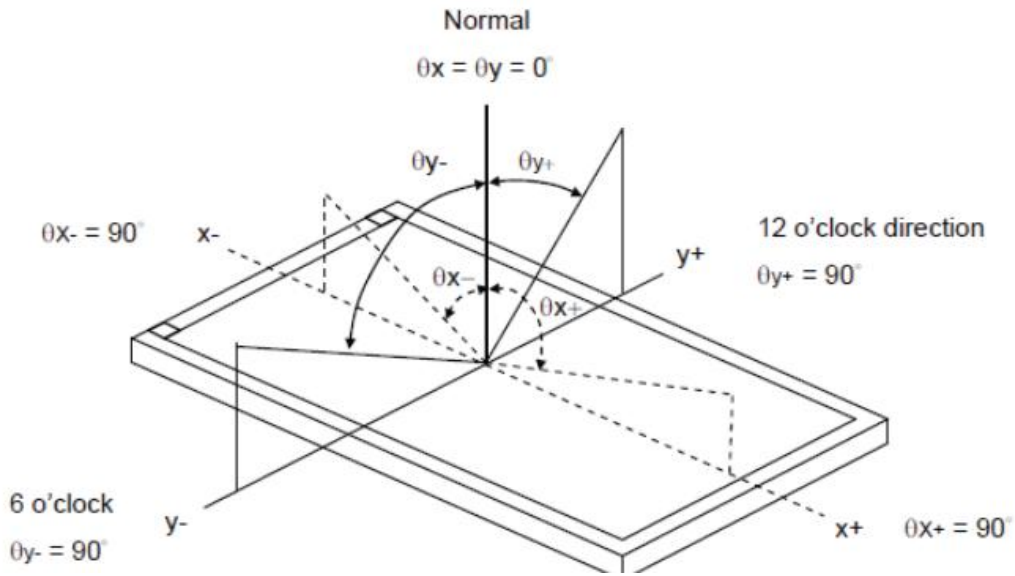

Note (3) Definition of Contrast Ratio (CR):

The contrast ratio can be calculated by the following expression.

$$\text{Contrast Ratio (CR)} = L_{255} / L_0$$

L255: Luminance of gray level 255

L 0: Luminance of gray level 0

CR = CR (5)

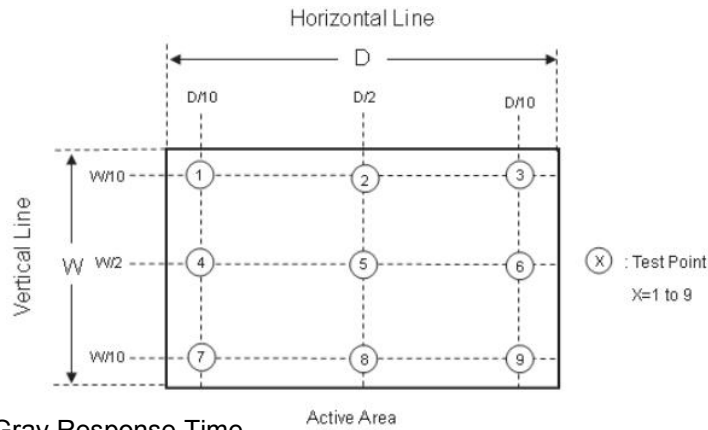

Note (4) Definition of Gray to Gray Response Time

G to G(BW) Response time is defined as the following figure and shall be measured by switching the input signal for "Gray(N)" and "Black or White".

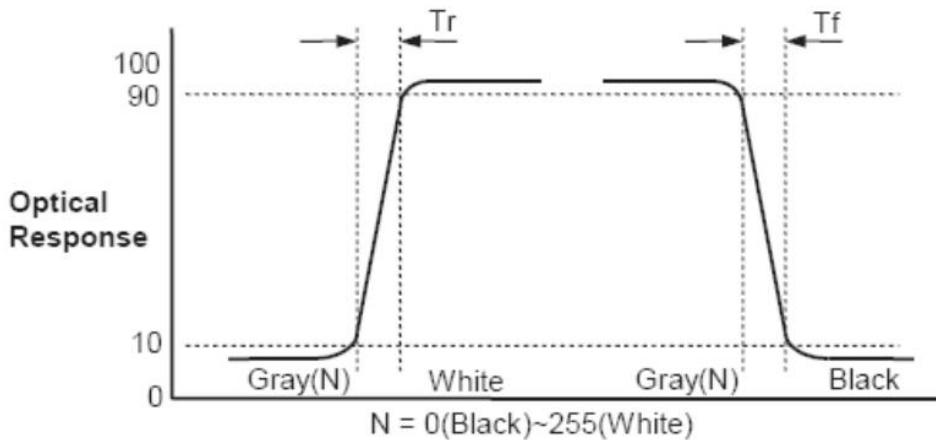

The Gray to Gray response time is defined as the following figure and shall be measured by switching the input signal for "Gray To Gray"

T_{GIG_AVE} is the total average time at rising time and falling time for "Gray To Gray".

- If system use ODC (Over Driving Circuit) function, T_{GIG_AVE} may be 5ms~8ms.

* It depends on Overshoot rate.

Gray to Gray		Rising time								
		0	31	63	95	127	159	191	233	255
Falling time	0									
	31									
	63									
	95									
	127									
	159									
	191									
	223									
	255									

Note (5) Definition of Luminance of White (L_c):

Measure the luminance of gray level 255 at center point

L_c = L (5)

L (x) is corresponding to the luminance of the point X at Figure in Note (3).

Note (6) Definition of Transmittance (T%):

Module is with signal input.

$$\text{Transmittance} = \frac{\text{Luminance of LCD module } L(5)}{\text{Luminance of backlight}} * 100\%$$

L(X) and LBLU(X) is corresponding to the luminance of the point X at Figure in Note(3).

Note (7) Measurement Setup:

The LCD module should be stabilized at given temperature for 40 minutes to avoid abrupt temperature change during measuring. In order to stabilize the luminance, the measurement should be executed after lighting Backlight for 40 minutes in a windless room.

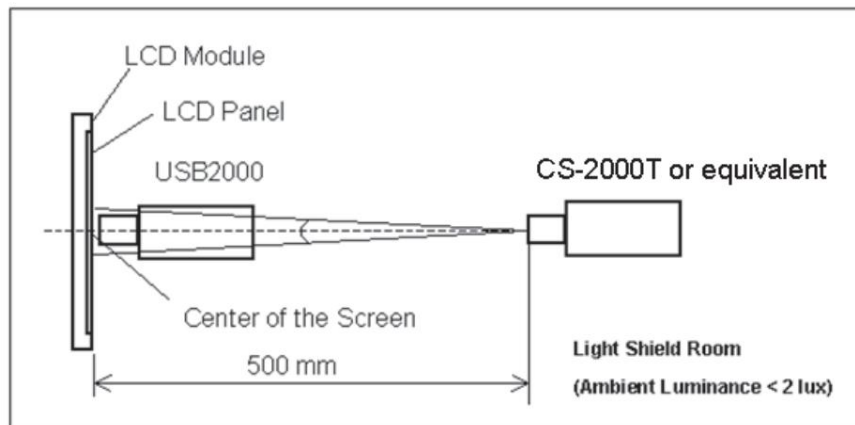

5.3 Flicker Adjustment

Flicker must be finely adjusted after module assembling and aging. Please follow the instructions below.

(1) Adjustment Pattern: 1+2line pattern as follows..

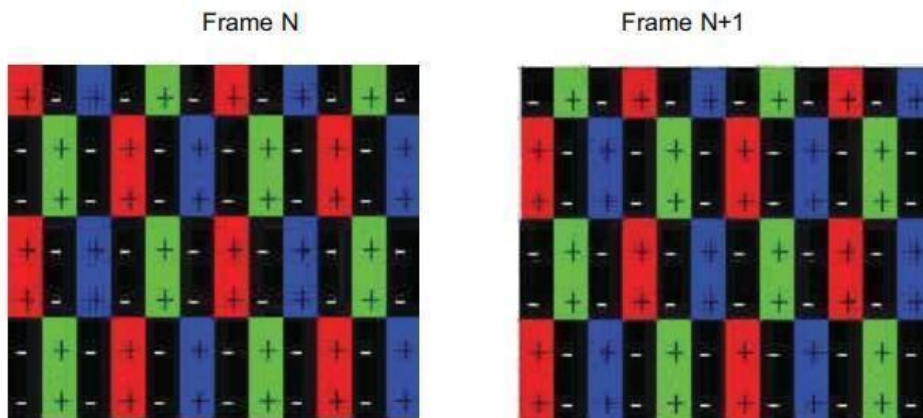

Note: Dark dots are gray level 0, and bright dots are gray level 128

(2) Adjustment Method:

Flicker should be adjusted by using the software of Auto-Vcom by the sensor. It is adjusted to the point with least flickering of the whole screen. After making it surely overrun at once, it should be adjusted to the optimum point.

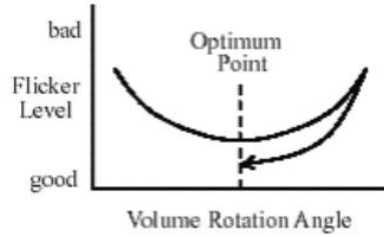

6. RELIABILITY TEST ITEM

Items	Required Condition	Note
Temperature Humidity Bias (THB)	Ta= 50°C, 80%RH, 240hours	(1)
High Temperature Operation (HTO)	Ta= 50°C, 50%RH 240hours	
Low Temperature Operation (LTO)	Ta= 0°C, 240hours	
High Temperature Storage (HTS)	Ta= 60°C, 240hours	
Low Temperature Storage (LTS)	Ta= -20°C, 240hours	
Package Vibration Test	ISTA STANDARD 1.14Grms Random, Frequency Range: 1 ~ 200 Hz Top & Bottom: 30 minutes (+Z), 10 min (-Z), Right & Left: 10 minutes (X) Back & Forth 10 minutes (Y)	(2)
Thermal Shock Test (TST)	-20 /30min, 60 / 30min, 100 cycles	(1)
On/Off Test	25 , On/10sec, Off /10sec, 30000 cycles	
Altitude Test	Operation: 10000 ft / 24hours Non-Operation: 30000 ft / 24hours	

Note (1) The tests are done with LCD modules .

Note (2) The test is done with a package shown in Section 8.

7. Electrical Interface Connection

7.1.LED Light Bar

connector CN2 : PH-

2P *1

Pin	Signal Name
1	VDD- (Black)
2	VDD+ (Red)



7.2 Recommended Operating Condition

(Ta=25°C)

Item	Symbol	Min.	Typ.	Max.	Unit
LED operation Voltage	V_{led}	50.4	-	57.6	V
LED operation Current	I_{led}	-	240	-	mA
Backlight Power	P_{BL}	12.1	-	13.83	W
Luminance	L	250	300		nit
LED Life Time		30000			Hrs
Luminance uniformity	ΔL	75	80		%

8.0 INPUT SIGNALS, BASIC DISPLAY COLORS & GRAY SCALE OF COLORS

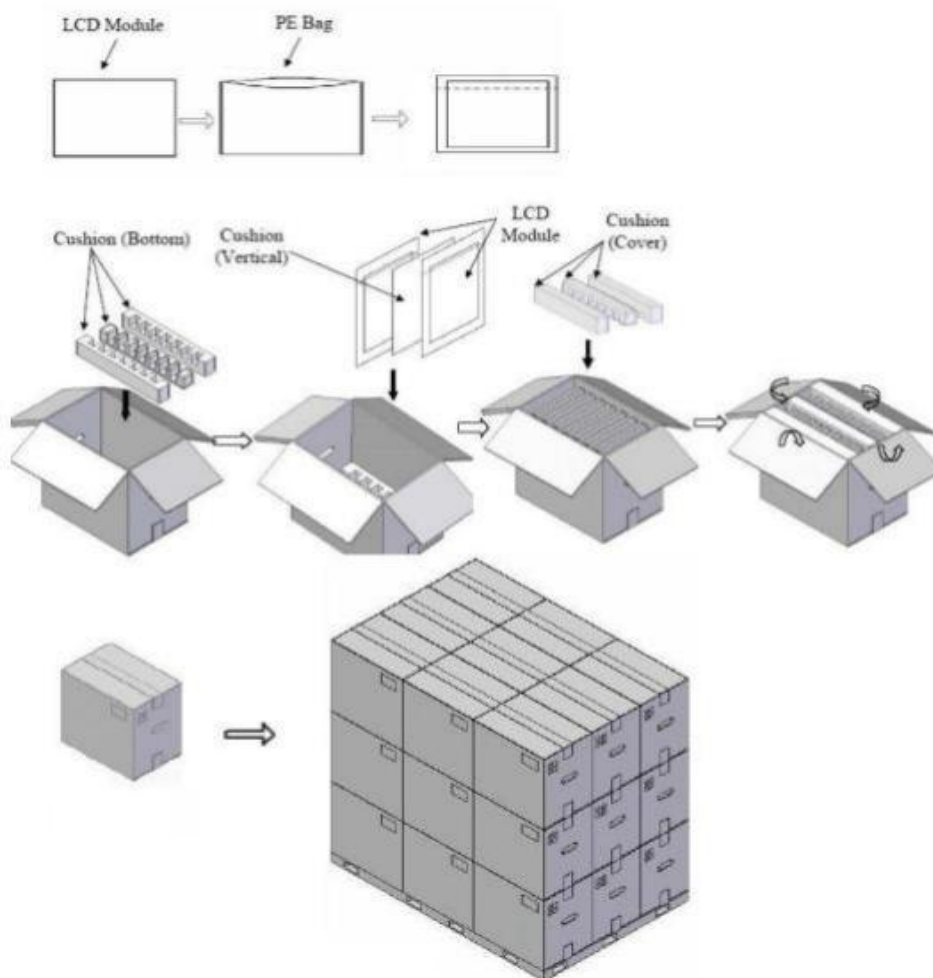

9. PRECAUTION

9.1 ASSEMBLY AND HANDLING PRECAUTIONS

1. Do not apply rough force such as bending or twisting to the module during assembly.
2. To assemble or install module into user's system can be in clean working areas. The dust and oil may cause electrical short or worsen the polarizer.
3. It's not permitted to have pressure or impulse on the module because the LCD panel and Backlight will be damaged.
4. Always follow the correct power sequence when LCD module is connecting and operating. This can prevent damage to the CMOS LSI chips during latch-up.
5. Do not pull the I/F connector in or out while the module is operating.
6. Do not disassemble the module. Use a soft dry cloth without chemicals for cleaning, because the surface of polarizer is very soft and easily scratched.
7. soft and easily scratched.

8. It is dangerous that moisture come into or contacted the LCD module, because moisture may damage LCD module when it is operating.
9. High temperature or humidity may reduce the performance of module. Please store LCD module within the specified storage conditions.
10. When ambient temperature is lower than 10 °C may reduce the display quality. For example, the response time will become slowly.

9.2 SAFETY PRECAUTIONS

- 1 It is dangerous that moisture come into or contacted the LCD module, because the moisture may damage LCD module when it is operating.
- 2 If the liquid crystal material leaks from the panel, it should be kept away from the eyes or mouth, in case of contact with hands, skin or clothes, it has to be washed away thoroughly with soap.
- 3 After the module's end of life, it is not harmful in case of normal operation and storage.

