

**CUSTOMER APPROVE**

**SPECIFICATION**  
**FOR**  
**DOUBLE LIN TFT-LCD MODULE**

**Edition : Preliminary spec 1.0**

**Date of issue : 2022-05-03**

**Product No. :M270HAN01.0**

<b>APPROVED</b>	<b>CHECKED</b>	<b>PREPARED</b>
Wei Yan	ZhongCai Liang	YongHeng Jia

## Revision History

Date	Rev.	Page	Old Description	New Description	Remark
2022-05-03	1.0	All	The specification was first issued		

# CONTENTS

Introduction  
Revision history

1. General Description	4
1.1 Display Characteristics	4
1.2 Absolute Maximum Rating of Environment	5
1.3 Optical Characteristics	6
1.4 Mechanical Characteristics	9
2. TFT LCD Module	10
2.1 Block Diagram	10
2.2 Interface Connection	10
2.3 Electrical characteristics	12
2.4 Signal Characteristics	13
3. Backlight Unit	15
3.1 Block Diagram	15
3.2 Recommended Operating Condition	15
3.3 Electrical Characteristics	15
4. Reliability Test Items(TBD)	16
5. Shipping Label	17
6. Precaution	19

# 1. General Description

This specification applies to the 27" inch wide Color a-Si TFT-LCD Module M270HAN01.0 The display supports the Full HD -1920(H) x 1080(V) screen format and 16.7M colors (RGB 8 bits+data inpu). The input interface is Dual channel LVDS and this module doesn't contain an driver board for backlights.

## 1.1. Display Characteristics

The following items are characteristics summary on the table under 25°C condition:

ITEMS	Unit	SPECIFICATIONS
Screen Dingonal	[mm]	685.65(27")
Active Area	[mm]	597.6 (H) ×336.15 (V)
Pixels H x V	-	1920 x 3(RGB)×1080
Pixels Pitch	[um]	311.25(per one triad) × 311.25
Pixels Arrangement	-	R.G.B. Vertical island
Display Mode	-	VA Mode, Nomrally Black
White Luminance(Center)	[cd/m <sup>2</sup> ]	1000 (Typ.)
Contrast Ratio	-	3000 (Typ.)
Response Time	[msec]	20 (Typ.Gray to Gray)
Viewing Angle	[degree]	89/89/89/89
Outline Dimension	[mm]	630.0(H) x 368.2(V) x 11.5(D) (Typ.)
Electrical Interface	-	Dual Channel LVDS
Support Color		16.7M colors (RGB 6 - bits +Hi - FRC data)
Surface Treatment		Anti-Glare 3H
Temperature Range Operating Storage(Shipping)	[oC] [oC]	0 to +50°C -20 to+60°C

## 1.2 Absolute Maximum Rating of Environment

Permanent damage may occur if exceeding the following maximum rating.

Symbol	Description	Min.	Max.	Unit	Remark
TOP	Operating Temperature	0	+50	[°C]	Note 2-1
TGS	Glass surface temperature	0	+65	[°C]	Note 2-1 Function judged only
HOP	Operation Humidity	5	90	[%RH]	Note 2-1
TST	Storage Temperature	-20	+60	[°C]	
HST	Storage Humidity	5	90	[%RH]	

Note 2-1 :Temperature and relative humidity range are shown as the below figure.

1. 90% RH Max( $T_a \leq 39^\circ\text{C}$ )
2. Max wet-bulb temperatuer at  $39^\circ\text{C}$  or less.( $T_a \leq 39^\circ\text{C}$ )
3. No condensation

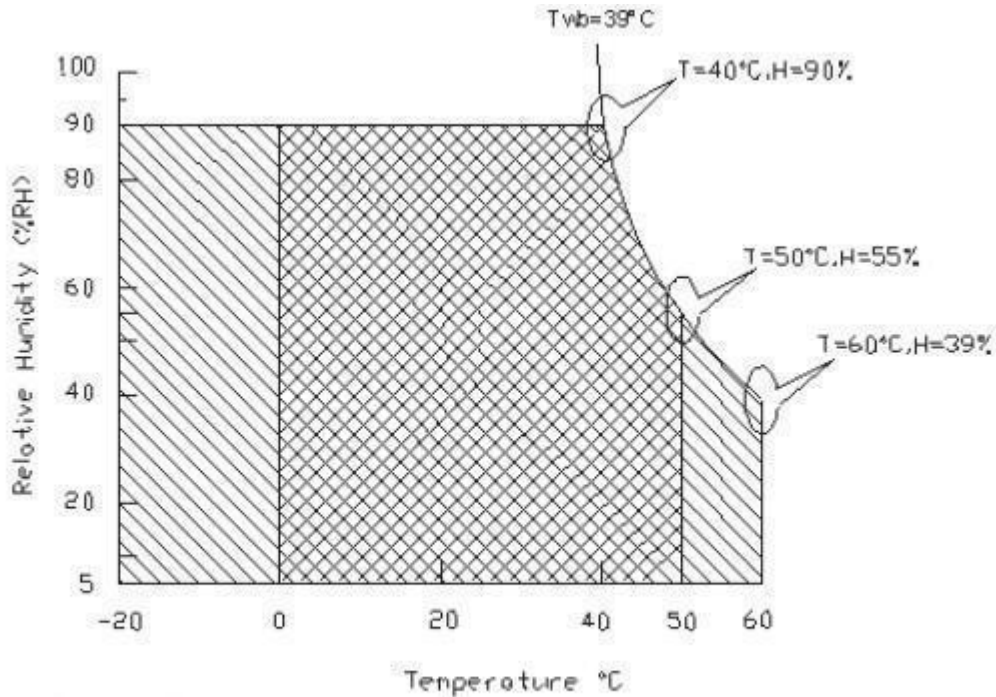

Operating Range



Storage Range

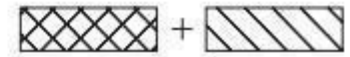

### 1.3.Optical Characteristics

The optical characteristics are measured on the following test condition.

#### Test Condition:

1. Equipment setup: Please refer to **Note 2 - 2**.
2. Panel Lighting time: 30 minutes
3. VDD=5.0V, Fv=60Hz, Is=60mA, Ta=25°C

Symbol	Description		Min.	Typ.	Max.	Unit	Remark
Lw	White Luminance (Center of screen)		800	1000	-	[cd/m2]	Note 2 - 2 By SR - 3
Luni	Luminance Uniformity (9 points)		75	80	-	%	Note 2 - 3 By SR - 3
Crr	Contrast Ratio (Center of screen)		1800	3000	-	-	Note 2 - 4 By SR - 3
θR	Horizontal Viewing Angle (CR=10)	Right	75	89	-	[degree]	Note 2 - 5 By SR - 3
θL		Left	75	89	-		
ΦH	Vertical Viewing Angle (CR=10)	Up	75	89	-		
ΦL		Down	75	89	-		
θR	Horizontal Viewing Angle (CR=5)	Right	75	89	-		
θL		Left	75	89	-		
ΦH	Vertical Viewing Angle (CR=5)	Up	75	89	-		
ΦL		Down	75	89	-		
T <sub>GTG</sub>	Response Time	Gray To Gray	-	20	-	[msec]	Note 2 - 6 ByTRD - 100
R <sub>x</sub>	Color Coordinates (CIE 1931)	Red x	0.593	0.623	0.653	-	By SR - 3
R <sub>y</sub>		Red y	0.318	0.348	0.378		
G <sub>x</sub>		Green x	0.274	0.304	0.334		
G <sub>y</sub>		Green y	0.621	0.651	0.681		
B <sub>x</sub>		Blue x	0.112	0.142	0.172		
B <sub>y</sub>		Blue y	0.623	0.653	0.683		
W <sub>x</sub>		White x	0.275	0.305	0.335		
W <sub>y</sub>		White y	0.342	0.372	0.402		
NTSC Area Ratio				72		[%]	By SR-3

**Note 2-2:** Equipment setup

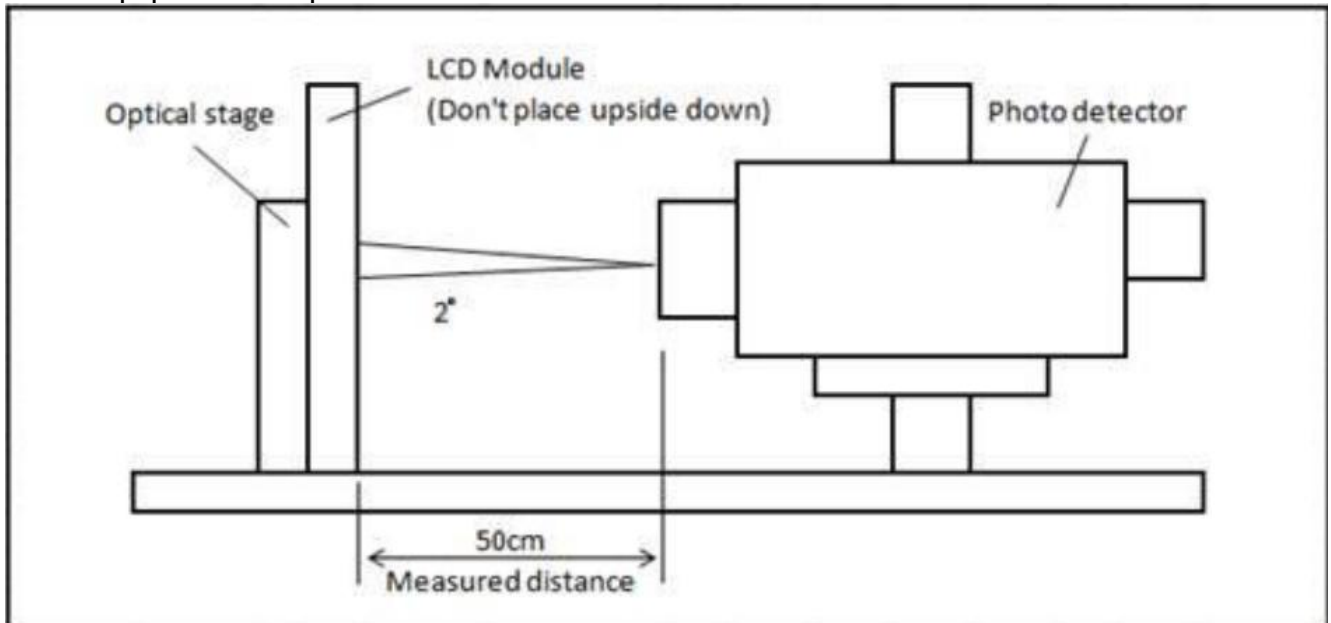

**Note 2-3:** Luminance Uniformity Measurement

**Definition:**

$$\text{Luminance Uniformity} = \frac{\text{Minimum Luminance of 9 Points (P1~P9)}}{\text{Maximum Luminance of 9 Points (P1~P9)}}$$

a. Test pattern: White Pattern

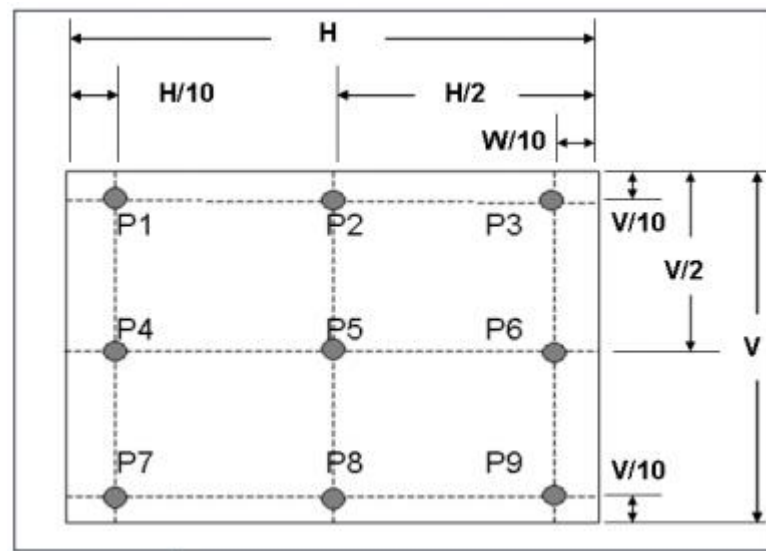

**Note 2-4: Contrast Ratio Measurement**

**Definition:**

$$\text{Contrast Ratio} = \frac{\text{Luminance of White pattern}}{\text{Luminance of Black pattern}}$$

- a. Measured position: Center of screen (P5) & perpendicular to the screen ( $\theta = \Phi = 0^\circ$ )

**Note 2-5: Viewing angle measurement**

**Definition:** The angle at which the contrast ratio is greater than 10 & 5 .

- a. Horizontal view angle: Divide to left & right ( $\theta_L$  &  $\theta_R$ )

Vertical view angle: Divide to up & down ( $\Phi_H$  &  $\Phi_L$ )

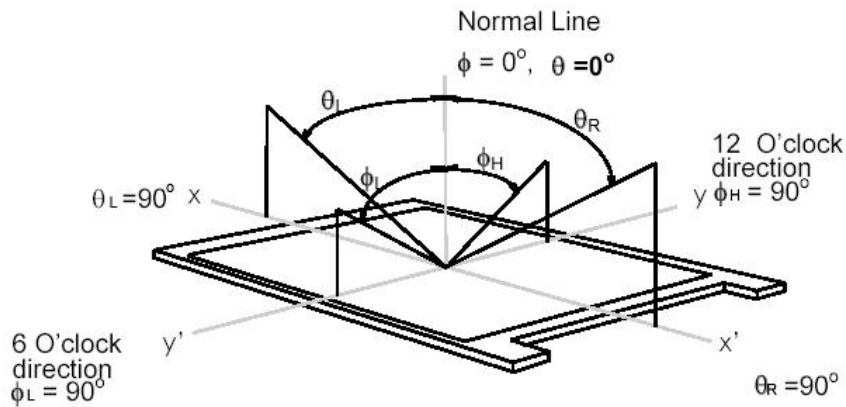

**Note 2-6: Response time measurement**

The output signals of photo detector are measured when the input signals are changed from “Gray level A” to “Gray level B” (faling time, TF), and from “Gray level B” to “Gray level A” (rising time, TR), respectively. The response time is interval between the 10% and 90% of optical response.

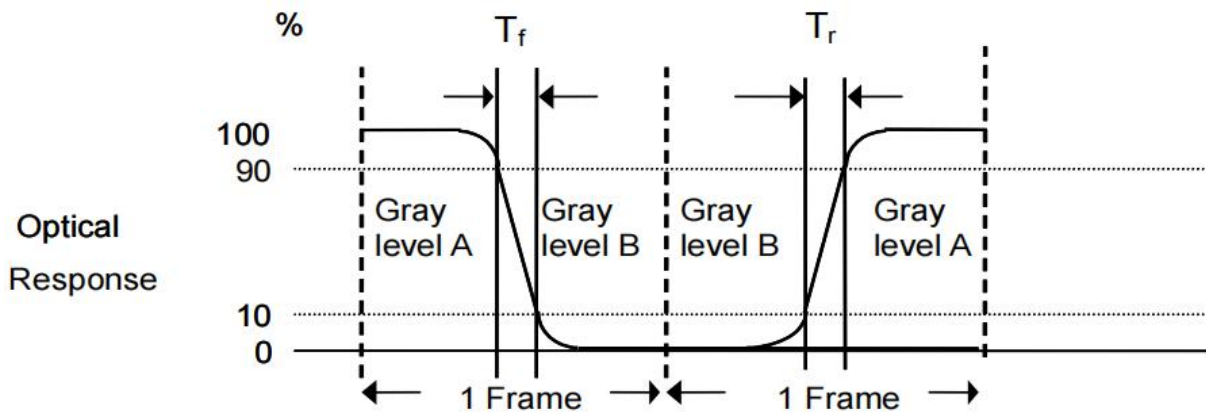

The output signals of photo detector are measured when the input signals are changed from “Gray level A” to “Gray level B”(faling time,TF),and from “Gray level B”to“Gray level A”(rising time,TR),respectively.The response time is interval between the10% and 90% of optical response.

The gray to gray response time is defined as the following table.

Gray Level to Gray Level		Target gray level				
		L0	L63	L127	L191	L255
Start gray level	L0					
	L63					
	L127					
	L191					
	L255					

$T_{GTG\_typ}$  is the total average time at rising time and falling time of gray to gray

#### 1.4 Mechanical Characteristics

Symbol	Description	Min.	Max.	Unit	Remark
$P_{bc}$	Backside Compression	2.5	-	[Kgf]	Note 2-8

#### Note 2-8: Test Method

The point is at a distance from right-downside 25mm x 25mm defined as the Start Point of Measure Points, and the point is at a distance 25mm from left-side & around 10mm from PCB defined as the End Point

Align 50mm x 50mm block from Start Point on the Bezel Back, and the corners of each block are Measure Points

If the distance from the last block to each side of the End Point  $\geq 25$ mm, add other block to make sure that most area of Bezel Back can be measured.

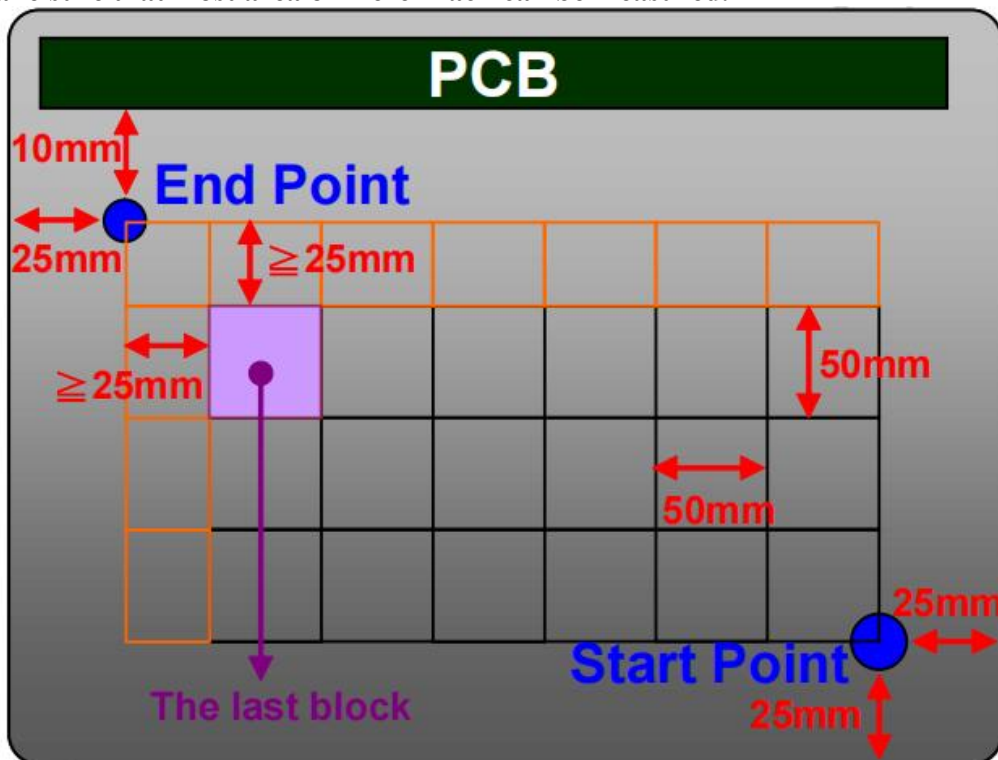

## 2 TFT-LCD Module

### 2.1 Block Diagram

The following shows the block diagram of the 27 inch Color TFT\_LCD Module

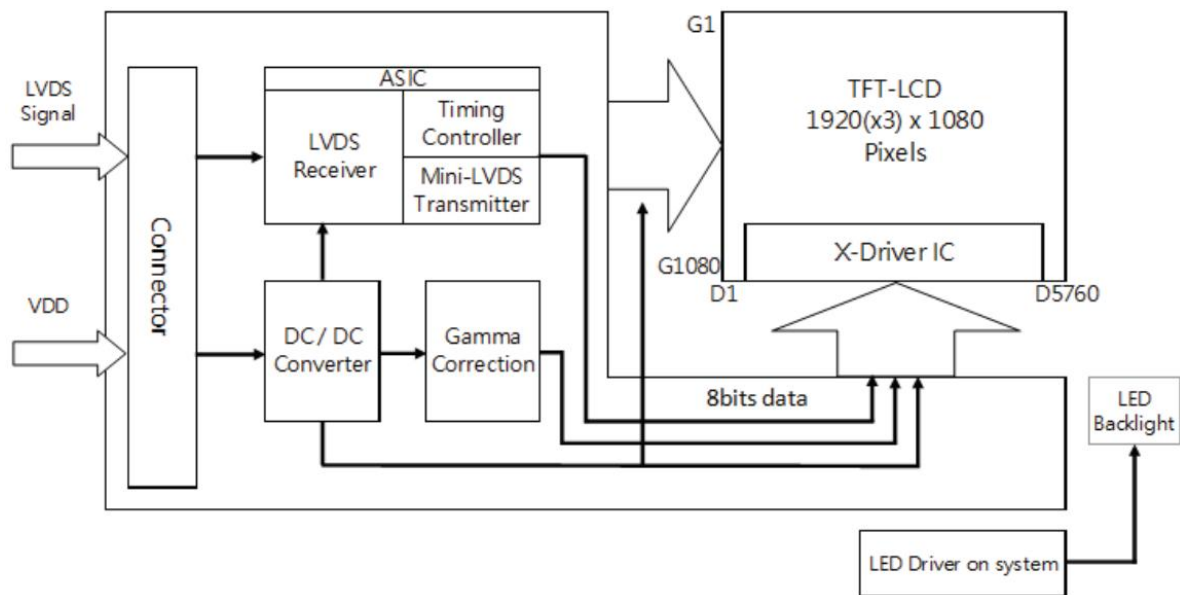

## 2.2 Interface Connection

### 2.2.1 Connector Type

TFT-LCD Connector	Manufacturer	P-TWO	STM
	Part Number	AL230F-A0GID-P	093G30-0200IA-M4
Mating Connector	Manufacture	JAE or Compatible	
	Part Number	FI-X30HL (Locked Type)	

## 2.2.2 LCD Connector Pin Assignment

PIN#	Symbol	DESCRIPTION
1	RxOIN0-	Negative LDVS differential data input (Odd data)
2	RxOIN0+	Positive LDVS differential data input (Odd data)
3	RxOIN1-	Negative LDVS differential data input (Odd data)
4	RxOIN1+	Positive LDVS differential data input (Odd data)
5	RxOIN2-	Negative LDVS differential data input (Odd data,H-Sync,V-Sync,DSPTMG)
6	RxOIN2+	Positive LDVS differential data input (Odd data,H-Sync,V-Sync,DSPTMG)
7	GND	Power Ground
8	RxOCLKIN-	Negative LDVS differential data input (Odd clock)
9	RxOCLKIN+	Positive LDVS differential data input (Odd clock)
10	RxOIN3-	Negative LDVS differential data input (Odd data)
11	RxOIN3+	Positive LDVS differential data input (Odd data)
12	RxEIN0-	Negative LDVS differential data input (Even data)
13	RxEIN0+	Positive LDVS differential data input (Even data)
14	GND	Power Ground
15	RxEIN1-	Negative LDVS differential data input (Even data)
16	RxEIN1+	Positive LDVS differential data input (Even data)
17	GND	Power Ground
18	RxEIN2-	Negative LDVS differential data input (Even data)
19	RxEIN2+	Positive LDVS differential data input (Even data)
20	RXECLKIN-	Negative LDVS differential data input (Even clock)
21	RXECLKIN+	Positive LDVS differential data input (Even clock)
22	RxEIN3-	Negative LDVS differential data input (Even data)
23	RxEIN3+	Positive LDVS differential data input (Even data)
24	GND	Power Ground
25	NC	No connection (For AUO test only.Do not connect)
26	NC	No connection (For AUO test only.Do not connect)
27	NC	No connection (For AUO test only.Do not connect)
28	VDD	+5.0V Power Supply
29	VDD	+5.0V Power Supply
30	VDD	+5.0V Power Supply

## 2.3 Electrical characteristics

### 2.3.1 Absolute Maximum Rating

Permanent damage may occur if exceeding the following maximum rating.

Symbol	Description	Min.	Max.	Unit.	Remark
VDD	Power Supply Input Voltage	GND-0.3	6.0	[Volt]	Ta=25 °C

### 2.3.2 Recommended Operating Condition

Symble	Description	Min.	Typ.	Max.	Unit	Remark
VDD	Power Supply Input Voltage	4.5	5.0	5.5	[Volt]	
IDD	Power Supply Input Current	-	0.93	1.22	[A]	VDD=5V, white Pattern, FV= 60Hz
			1.22	1.46	[A]	VDD=5V, white Pattern, FV= 75Hz
IRush	Input Current	-	-	3.0	[A]	Note 3-1
PDD	VDD Power Consumption	-	4.65	6.1	[Watt]	VDD=5V, white Pattern, FV= 60Hz
			6.10	7.30	[Watt]	VDD=5V, white Pattern, FV= 70Hz
VDDrp	Allowable VDD Ripple Voltage	-	-	500	[mV]	VDD=5V, white Pattern, FV= 75Hz

Note 3-1: Inrush Current measurement

#### Test circuit:

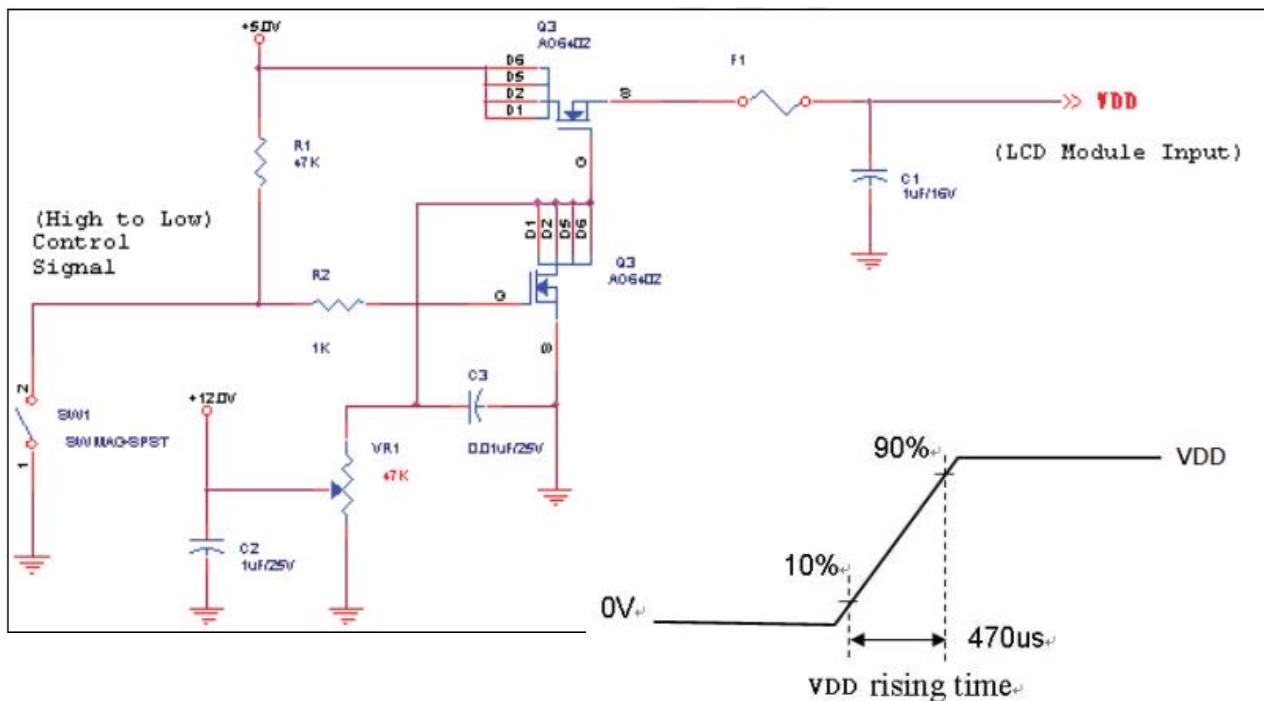

The duration of VDD rising time: 470us.

## 2.4 Signal Characteristics

### 2.4.1 LCD Pixel Format

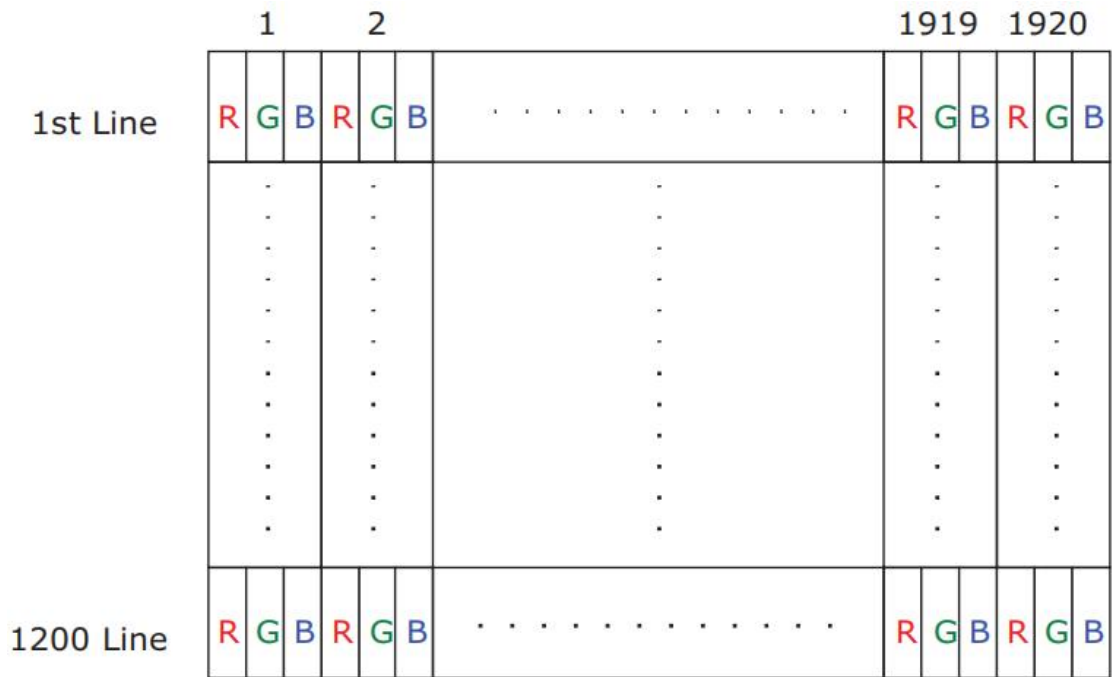

### 2.4.2 LVDS Data Format

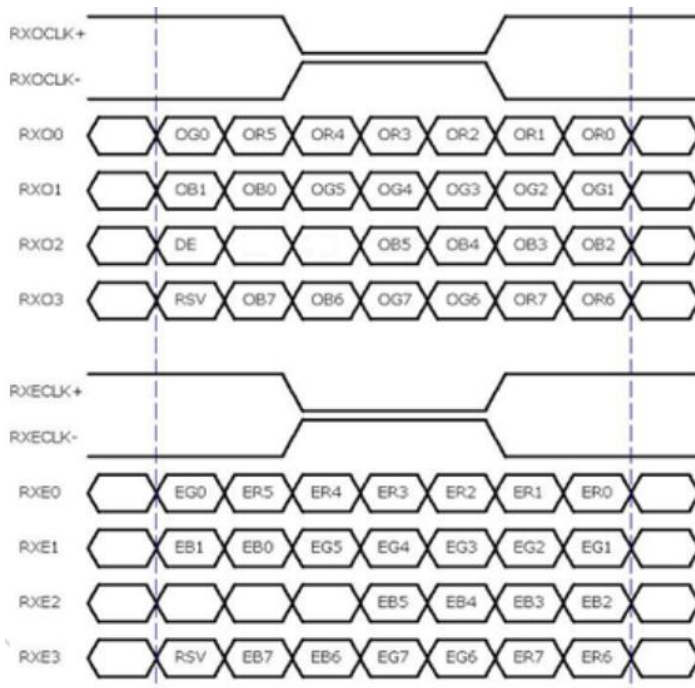

8 Bit Color Bit Order			
<b>MSB</b>	R7	G7	B7
	R6	G6	B6
	R5	G5	B5
	R4	G4	B4
	R3	G3	B3
	R2	G2	B2
	R1	G1	B1
<b>LSB</b>	R0	G0	B0

Note 3-2

- O = "Odd Pixel Data"      E = "Even Pixel Data"
- Refer to 2.4.1 LCD pixel format, the 1st data is I(Odd Pixel Data), the 2nd data is 2(Even Pixel Data) And the last data is I920(Even Pixel Data).

### 2.4.3 Color versus Input Data

The following table is for color versus input data(8bit).The higher the gray level,the brighter the color

Color	Gray Level	Color Input Data																				Remark				
		RED data (MSB:R7, LSB:R0)								GREEN data (MSB:G7, LSB:G0)								BLUE data (MSB:B7, LSB:B0)								
		R7	R6	R5	R4	R3	R2	R1	R0	G7	G6	G5	G4	G3	G2	G1	G0	B7	B6	B5	B4		B3	B2	B1	B0
Black	-	0	0	0	0	0	0	0	0	0	0	0	0	0	0	0	0	0	0	0	0	0	0	0		
White	-	1	1	1	1	1	1	1	1	1	1	1	1	1	1	1	1	1	1	1	1	1	1	1		
Gray 127	-	0	1	1	1	1	1	1	1	0	1	1	1	1	1	1	0	1	1	1	1	1	1	1		
Red	L0	0	0	0	0	0	0	0	0	0	0	0	0	0	0	0	0	0	0	0	0	0	0	0	Black	
	:	:	:	:	:	:	:	:	:	:	:	:	:	:	:	:	:	:	:	:	:	:	:	:		
	L255	1	1	1	1	1	1	1	1	0	0	0	0	0	0	0	0	0	0	0	0	0	0	0		
Green	L0	0	0	0	0	0	0	0	0	0	0	0	0	0	0	0	0	0	0	0	0	0	0	0	Black	
	:	:	:	:	:	:	:	:	:	:	:	:	:	:	:	:	:	:	:	:	:	:	:	:		
	L255	0	0	0	0	0	0	0	0	1	1	1	1	1	1	1	1	0	0	0	0	0	0	0		
Blue	L0	0	0	0	0	0	0	0	0	0	0	0	0	0	0	0	0	0	0	0	0	0	0	0	Black	
	:	:	:	:	:	:	:	:	:	:	:	:	:	:	:	:	:	:	:	:	:	:	:	:		
	L255	0	0	0	0	0	0	0	0	0	0	0	0	0	0	0	0	1	1	1	1	1	1	1		

### 2.4.4 LVDS Specification

#### DC Characteristics:

Symbol	Description	Min	Typ	Max	Units	Condition
$V_{TH}$	LVDS Differential Input High Threshold	-	-	+100	[mV]	$V_{CM}=1.2V$
$V_{TL}$	LVDS Differential Input High Threshold	-100	-	-	[mV]	$V_{CM}=1.2V$
$ V_{ID} $	LVDS Differential Input High Voltage	100	-	600	[mV]	
$V_{CM}$	LVDS Common Mode Voltage	+1.0	+1.2	+1.5	[V]	$V_{TH}-V_{TL}=200mV$

## 3 Backlight Unit

### 3.1 Block Diagram

The following shows the block diagram of the 27 inch Backlight Unit, And it includes 72pcs LED in the LED light bar.(8 strings and 9 pcs LED one string).

### 3.2 Recommended Operating Condition

(Ta=25°C)

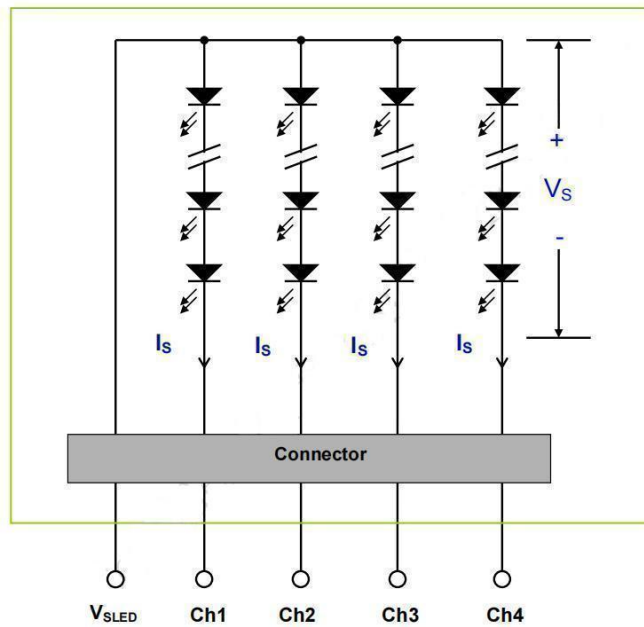

Item	Symbol	Min.	Typ.	Max.	Unit
LED operation Voltage	$V_{led}$	47.2	-	52	V
LED operation Current	$I_{led}$	-	900	-	mA
Backlight Power	$P_{BL}$	42.48	-	46.8	W
Luminance	L	800	1000		nit
LED Life Time		30000			Hrs
Luminance uniformity	$\Delta L$	75	80		%

### 3.3 Backlight Electrical / Optical Characteristics

Backlight

connector CN2 : PH-

2P \*2

Pin	Signal Name
1	VDD- (Black)
2	VDD+ (Red)



#### 4 Reliability Test

AUO reliability test items are listed ad following table.(Bare panel only)

Ltems	Condition	Remark
Temperature Humidity Bias(THB)	Ta= 50°C, 80%RH, 300huurs	
High Temperature Operation(HTO)	Ta= 50°C, 50%RH, 300huurs	
Low Temperature Operation(LTO)	Ta= 0°C, 300huurs	
High Temperature Storage (HTS)	Ta= 60°C, 300huurs	
Low Temperature Storage (LTS)	Ta= -20°C, 300huurs	
Vibration Test (Non-operation)	Acceleration: 1.5 Grms Wave: Random Frequency:10-200 Hz Sweep:30 Minutes each Axis (X,Y,Z)	
Shock Test (Non-operation)	Acceleration: 50Grms Wave: Half-sine Active TIMIE: 20ms Direction : ± X, ± Y, ± Z(one time for each Axis)	
Thermal Shock Test(TST)	-20°C/30min, 60°C/30min,100 cycles	
On/Off Test	On/10sec,Off/10sec,30,000 cycles	Note 4-1
ESD(Elector Static Dishcharge)	Contact Discharge: ± 15KV, 150pF(330 Ω ) 1sec, 8 points, 25 times/point	Note 4-2
	Air Discharge: ± 15KV, 150pF(330 Ω ) 1sec, 8 points, 25 times/point	
Altitude Test	Operation:18,000 ft Non-Operation:40,000ft	

**Note 4-1 a.** A cycle of rapid temperature change consists of varying the temperature fron -20°C to 60°C ,  
And back again. Power is not applied during the test.

**b.** After finish temperature cycling, the unit is placed in normal room ambient for at least 4 hours  
before power on.

**Note 4-2 EN61000-4-2,ESD class B:** Certain performance degradation allowed

No data lost

Self-recoverable

No hardware failures.

## 5.Shipping Label

The label is on the panel as shown below



玻璃厂商代码+尺

Parameter	Packing box	Unit
Size	670 (L) 282(W) x412 (H) (typ.)	mm
Weight	3.1(typ.)	kg
Total weight	31 (typ.) (with 10 products)	kg

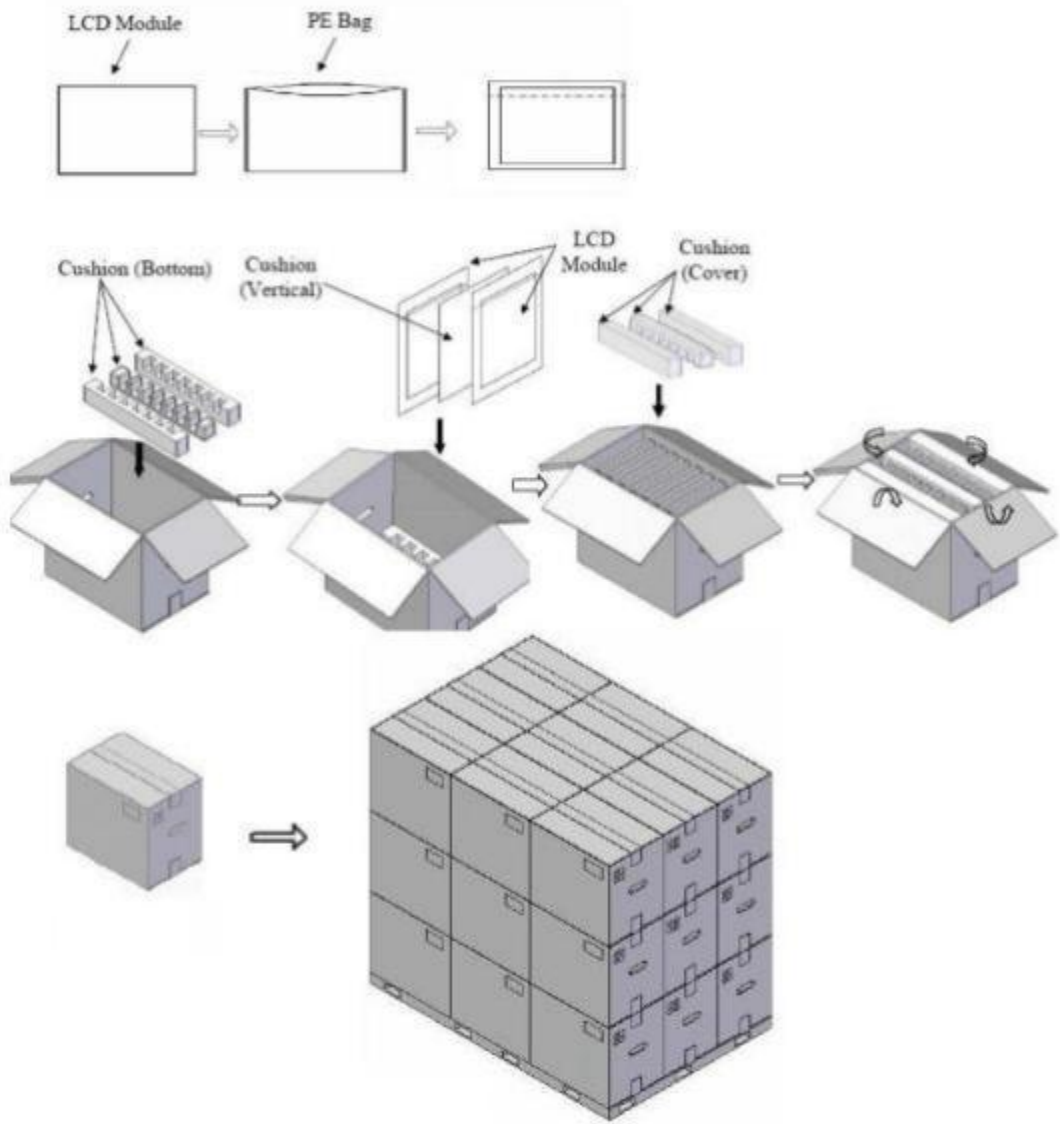

## 6. PRECAUTION

### 6.1 ASSEMBLY AND HANDLING PRECAUTIONS

1. Do not apply rough force such as bending or twisting to the module during assembly.
2. To assemble or install module into user's system can be in clean working areas. The dust and oil may cause electrical short or worsen the polarizer.
3. It's not permitted to have pressure or impulse on the module because the LCD panel and Backlight will be damaged.
4. Always follow the correct power sequence when LCD module is connecting and operating. This can prevent damage to the CMOS LSI chips during latch-up.
5. Do not pull the I/F connector in or out while the module is operating.
6. Do not disassemble the module. Use a soft dry cloth without chemicals for cleaning, because the surface of polarizer is very soft and easily scratched.
7. It is dangerous that moisture come into or contacted the LCD module, because moisture may damage LCD module when it is operating.
8. High temperature or humidity may reduce the performance of module. Please store LCD module within the specified storage conditions.
9. When ambient temperature is lower than 10 °C may reduce the display quality. For example, the response time will become slowly.

### 6.2 SAFETY PRECAUTIONS

- 1 It is dangerous that moisture come into or contacted the LCD module, because the moisture may damage LCD module when it is operating.
- 2 If the liquid crystal material leaks from the panel, it should be kept away from the eyes or mouth, in case of contact with hands, skin or clothes, it has to be washed away thoroughly with soap.
- 3 After the module's end of life, it is not harmful in case of normal operation and storage.

