

CUSTOMER APPROVE

ATION

FOR

DOUBLE LIN TFT-LCD MODULE

Edition : Preliminary spec 1.0

Date of issue : 2022-05-03

Product No. :M270HAN01.0

APPROVED	CHECKED	PREPARED
Wei Yan	ZhongCai Liang	YongHeng Jia

Revision History

Date	Rev.	Page	Old Description	New Description	Remark
2022-05-03	1.0	All	The specification was first issued		

CONTENTS

SPECIFICATION -----	1
DOUBLE LIN TFT-LCD MODULE -----	1
Revision History -----	2
CONTENTS -----	3
1. General Description -----	4
1.1 Display Characteristics -----	4
1.2 Absolute Maximum Rating of Environment -----	5
1.3 Optical Characteristics -----	6
1.4 Mechanical Characteristics -----	9
2. TFT-LCD Module -----	10
2.1 Block Diagram -----	10
2.2 Interface Connection -----	10
2.3 Electrical characteristics -----	12
2.4 Signal Characteristics -----	13
3. Backlight Unit -----	16
3.1 Block Diagram -----	16
3.2 Interface Connection -----	17
3.3 Backlight Electrical / Optical Characteristics -----	17
4. Reliability Test -----	18
5. Shipping Label -----	19
6. Precaution -----	20
6.1 assembly and handling precautions -----	20
6.2 Safety precautions -----	21

1. General Description

This specification applies to the 27" inch wide Color a-Si TFT-LCD Module M270HAN01.0 The display supports the Full HD -1920(H) x 1080(V) screen format and 16.7M colors (RGB 8 bits+data inpu). The input interface is Dual channel LVDS and this module doesn't contain an driver board for backlights.

1.1 Display Characteristics

The following items are characteristics summary on the table under 25°C condition:

ITEMS	Unit	SPECIFICATIONS
Screen Dingonal	[mm]	685.65(27")
Active Area	[mm]	597.6 (H) ×336.15 (V)
Pixels H x V	-	1920 x 3 (RGB) × 1080
Pixels Pitch	[um]	311.25(per one triad) × 311.25
Pixels Arrangement	-	R.G.B. Vertical island
Display Mode	-	VA Mode,Nomrally Black
White Luminance(Center)	[cd/m ²]	500 (Typ.)
Contrast Ratio	-	3000 (Typ.)
Response Time	[msec]	20 (Typ.Gray to Gray)
Viewing Angle	[degree]	89/89/89/89
Outline Dimension	[mm]	613.8 (H) x 356.9 (V) x 10.6 (D) (Typ.)
Electrical Interface	-	Dual Channel LVDS
Support Color		16.7M colors (RGB 6 - bits +Hi - FRC data)
Surface Treatment		Anti-Glare 3H
Temperature Range Operating Storage(Shipping)	[oC] [oC]	0 to +50°C -20 to+60°C

1.2 Absolute Maximum Rating of Environment

Permanent damage may occur if exceeding the following maximum rating.

Symbol	Description	Min.	Max.	Unit	Remark
TOP	Operating Temperature	0	+50	[°C]	Note 2-1
TGS	Glass surface temperature	0	+65	[°C]	Note 2-1 Function judged only
HOP	Operation Humidity	5	90	[%RH]	Note 2-1
TST	Storage Temperature	-20	+60	[°C]	
HST	Storage Humidity	5	90	[%RH]	

Note 2-1 : Temperature and relative humidity range are shown as the below figure.

90% RH Max($T_a \leq 39^\circ\text{C}$)

Max wet-bulb temperatuer at 39°C or less.($T_a \leq 39^\circ\text{C}$)

No condensation

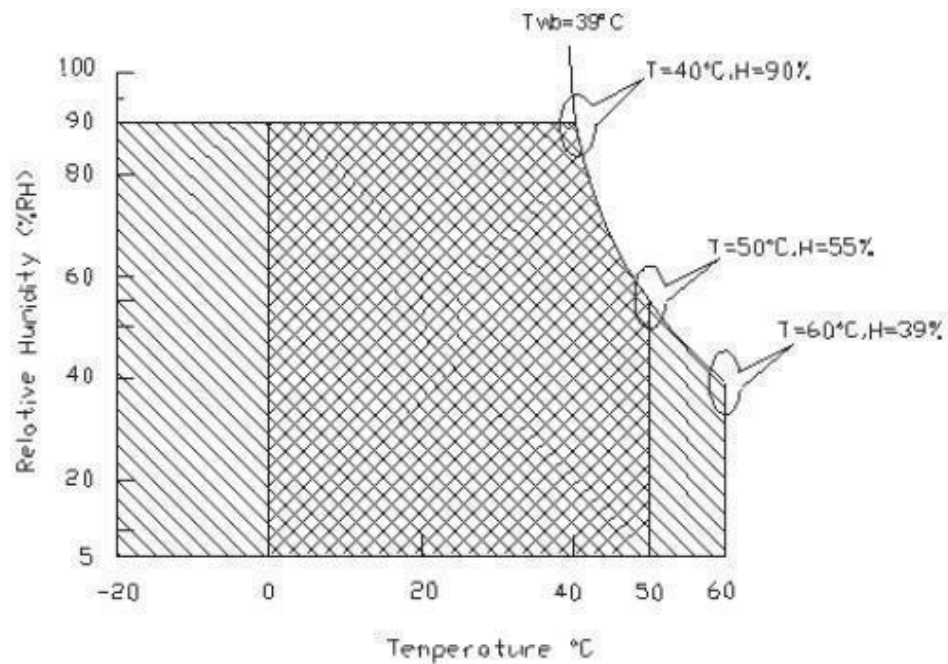

Operating Range



Storage Range

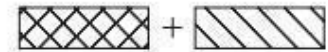

1.3 Optical Characteristics

The optical characteristics are measured on the following test condition.

Test Condition:

1. Equipment setup: Please refer to Note 2 - 2.
2. Panel Lighting time: 30 minutes
3. VDD=5.0V, Fv=60Hz, Is=60mA, Ta=25°C

Symbol	Description		Min.	Typ.	Max.	Unit	Remark
Lw	White Luminance (Center of screen)		400	500	-	[cd/m ²]	Note 2 - 2 By SR - 3
Luni	Luminance Uniformity (9 points)		75	80	-	%	Note 2 - 3 By SR - 3
Crr	Contrast Ratio (Center of screen)		1800	3000	-	-	Note 2 - 4 By SR - 3
θR	Horizontal Viewing Angle (CR=10)	Right	75	89	-	[degree]	Note 2 - 5 By SR - 3
θL		Left	75	89	-		
ΦH	Vertical Viewing Angle (CR=10)	Up	75	89	-		
ΦL		Down	75	89	-		
θR	Horizontal Viewing Angle (CR=5)	Right	75	89	-		
θL		Left	75	89	-		
ΦH	Vertical Viewing Angle (CR=5)	Up	75	89	-		
ΦL		Down	75	89	-		
TGTG	Response Time	Gray To Gray	-	20	-	[msec]	Note 2 - 6 By TRD - 10 0
Rx	Color Coordinates (CIE 1931)	Red x	0.592	0.622	0.652	-	By SR - 3
Ry		Red y	0.311	0.341	0.371		
Gx		Green x	0.268	0.298	0.328		
Gy		Green y	0.595	0.625	0.655		
Bx		Blue x	0.116	0.146	0.176		
By		Blue y	0.024	0.054	0.084		
Wx		White x	0.251	0.281	0.311		
Wy		White y	0.290	0.320	0.350		
NTSC Area Ratio				72		[%]	By SR-3

Note2-2:Equipment setup

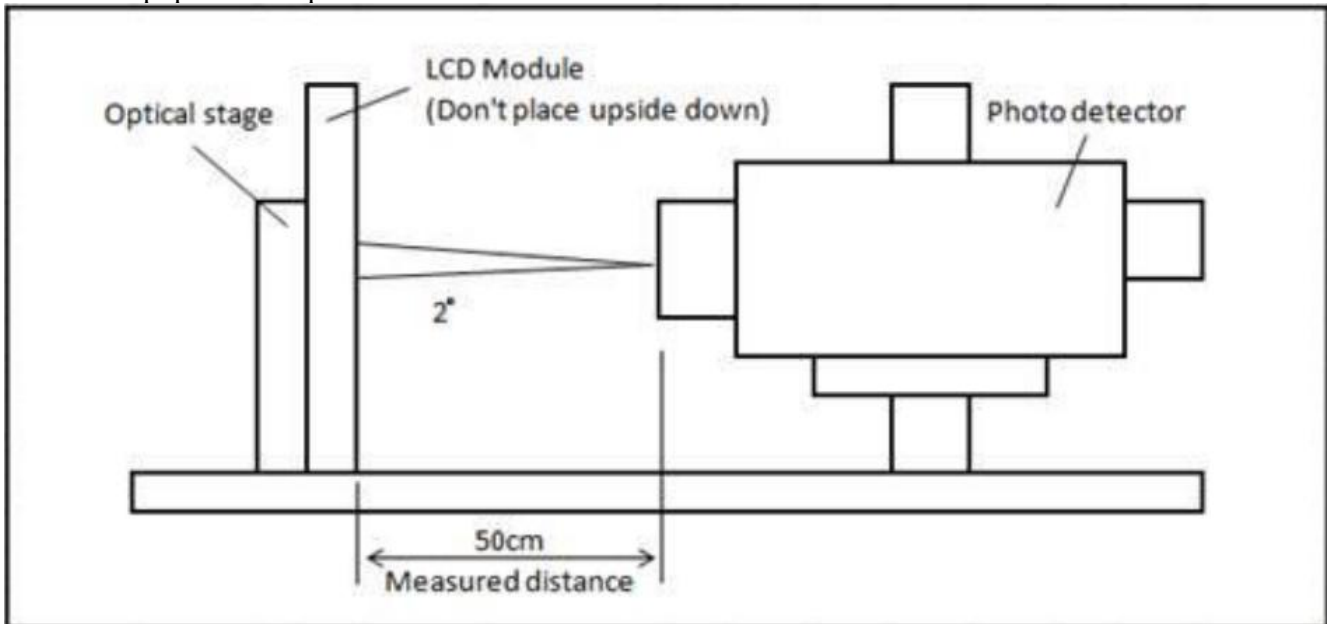

Note 2-3: Luminance Uniformity Measurement

Definition:

$$\text{Luminance Uniformity} = \frac{\text{Minimum Luminance of 9Points(P1~P9)}}{\text{Maximum Luminance of 9Points(P1~P9)}}$$

a. Test pattern: White Pattern

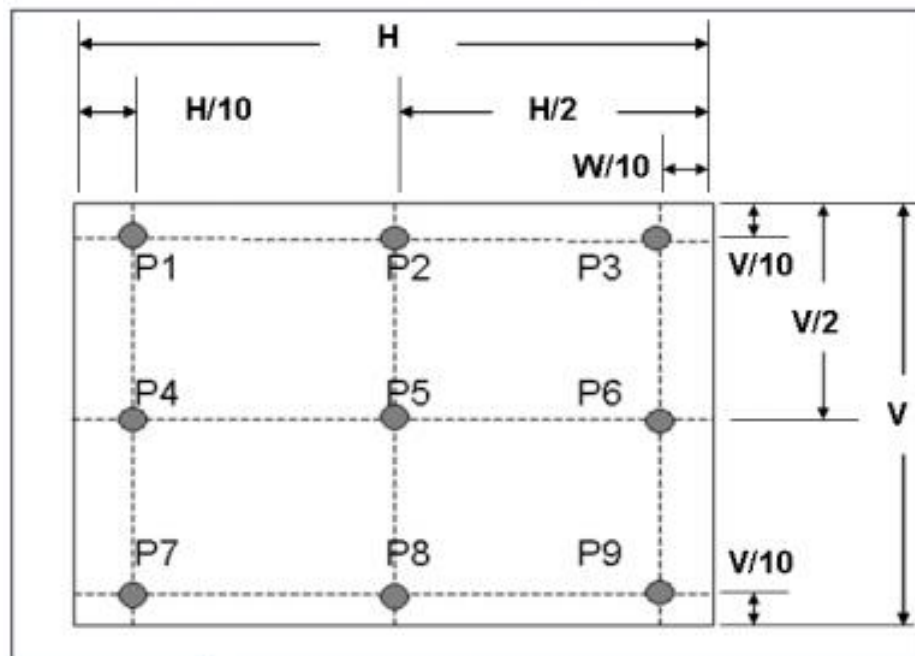

Note 2-4: Contrast Ratio Measurement

Definition:

$$\text{Contrast Ratio} = \frac{\text{Luminance of White pattern}}{\text{Luminance of Black pattern}}$$

a. Measured position: Center of screen (P5) & perpendicular to the screen ($\theta = \Phi = 0^\circ$)

Note 2-5: Viewing angle measurement

Definition: The angle at which the contrast ratio is greater than 10 & 5 .

a. Horizontal view angle: Divide to left & right (θ_L & θ_R)

Vertical view angle: Divide to up & down (Φ_H & Φ_L)

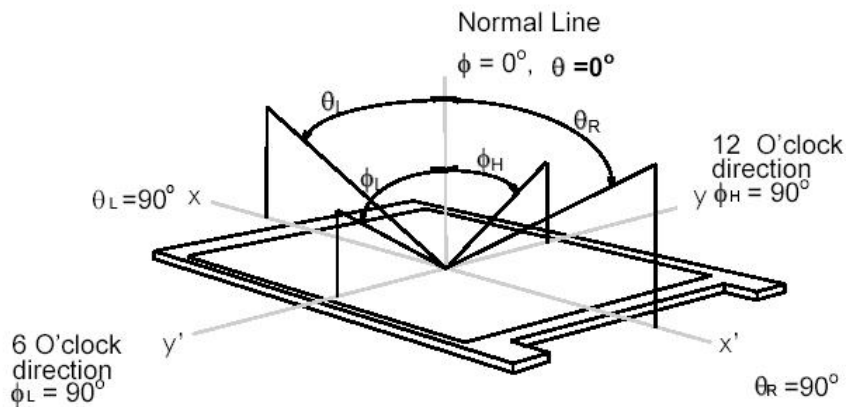

Note 2-6: Response time measurement

The output signals of photo detector are measured when the input signals are changed from “Gray level A” to “Gray level B” (falling time, TF), and from “Gray level B” to “Gray level A” (rising time, TR), respectively. The response time is interval between the 10% and 90% of optical response.

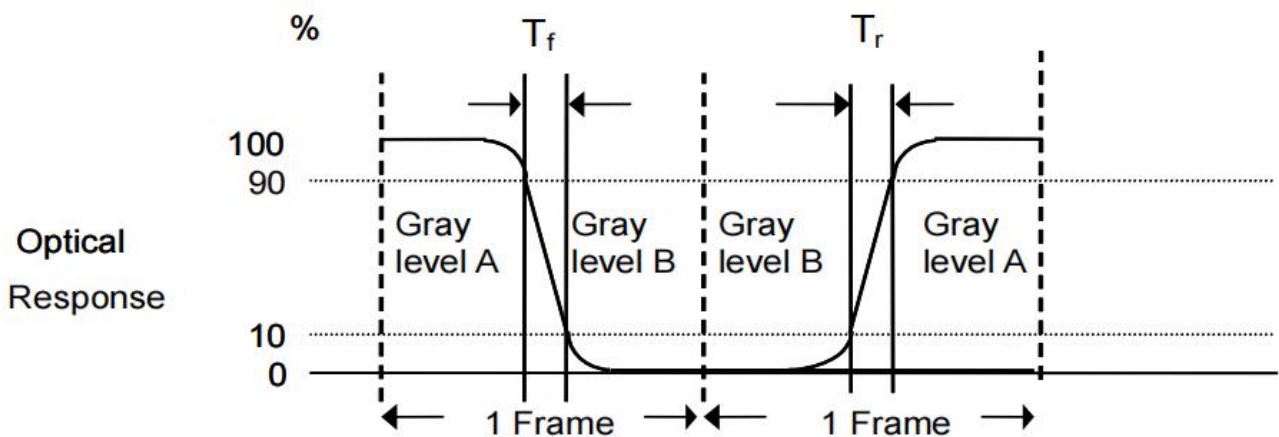

The output signals of photo detector are measured when the input signals are changed from “Gray level A” to “Gray level B” (falling time, TF), and from “Gray level B” to “Gray level A” (rising time, TR), respectively. The response time is interval between the 10% and 90% of optical response.

The gray to gray response time is defined as the following table.

Gray Level to Gray Level		Target gray level				
		L0	L63	L127	L191	L255
Start gray level	L0					
	L63					
	L127					
	L191					
	L255					

TGTG_typ is the total average time at rising time and falling time of gray to gray

1.4 Mechanical Characteristics

Symbol	Description	Min.	Max.	Unit	Remark
P _{bc}	Backside Compression	2.5	-	[Kgf]	Note 2-8

Note 2-8: Test Method

The point is at a distance from right-downside 25mm x 25mm defined as the Start Point of Measure Points, and the point is at a distance 25mm from left-side & around 10mm from PCB defined as the End Point

Align 50mm x 50mm block from Start Point on the Bezel Back, and the corners of each block are Measure Points

If the distance from the last block to each side of the End Point ≥ 25 mm, add other block to make sure that most area of Bezel Back can be measured.

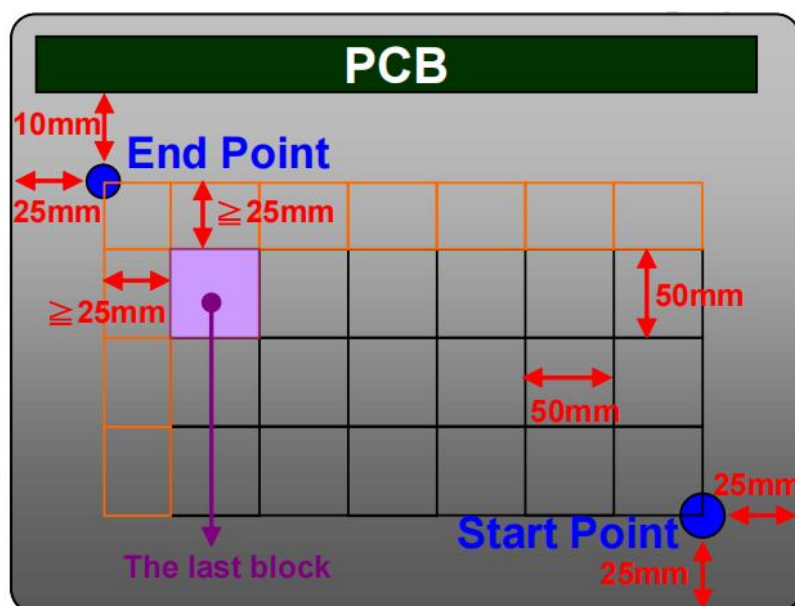

2. TFT-LCD Module

2.1 Block Diagram

The following shows the block diagram of the 27 inch Color TFT_LCD Module

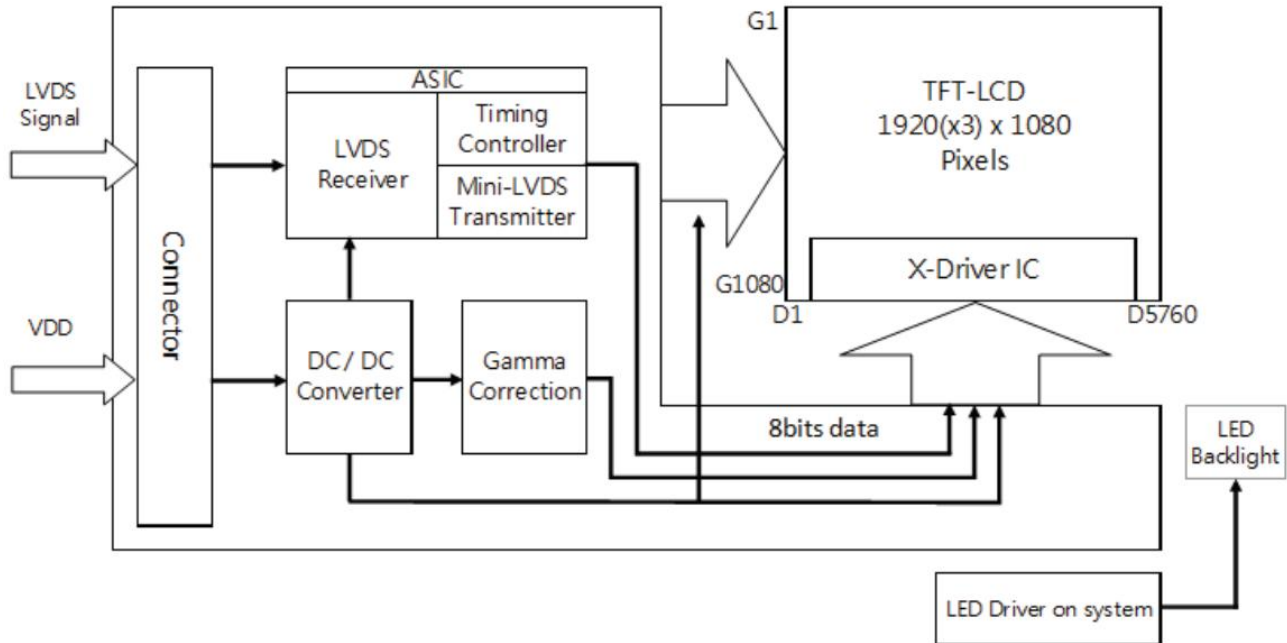

2.2 Interface Connection

2.2.1 Connector Type

TFT-LCD Connector	Manufacturer	P-TWO	STM
	Part Number	AL230F-A0GID-P	093G30-0200IA-M4
Mating Connector	Manufacture	JAE or Compatible	
	Part Number	FI-X30HL (Locked Type)	

2.2.2 LCD Connector Pin Assignment

PIN#	Symbol	DESCRIPTION
1	RxOIN0-	Negative LDVS differential data input (Odd data)
2	RxOIN0+	Positive LDVS differential data input (Odd data)
3	RxOIN1-	Negative LDVS differential data input (Odd data)
4	RxOIN1+	Positive LDVS differential data input (Odd data)
5	RxOIN2-	Negative LDVS differential data input (Odd data,H-Sync,V-Sync,DSPTMG)
6	RxOIN2+	Positive LDVS differential data input (Odd data,H-Sync,V-Sync,DSPTMG)
7	GND	Power Ground
8	RxOCLKIN-	Negative LDVS differential data input (Odd clock)
9	RxOCLKIN+	Positive LDVS differential data input (Odd clock)
10	RxOIN3-	Negative LDVS differential data input (Odd data)
11	RxOIN3+	Positive LDVS differential data input (Odd data)
12	RxEIN0-	Negative LDVS differential data input (Even data)
13	RxEIN0+	Positive LDVS differential data input (Even data)
14	GND	Power Ground
15	RxEIN1-	Negative LDVS differential data input (Even data)
16	RxEIN1+	Positive LDVS differential data input (Even data)
17	GND	Power Ground
18	RxEIN2-	Negative LDVS differential data input (Even data)
19	RxEIN2+	Positive LDVS differential data input (Even data)
20	RXECLKIN-	Negative LDVS differential data input (Even clock)
21	RXECLKIN+	Positive LDVS differential data input (Even clock)
22	RxEIN3-	Negative LDVS differential data input (Even data)
23	RxEIN3+	Positive LDVS differential data input (Even data)
24	GND	Power Ground
25	NC	No connection (For AUO test only.Do not connect)
26	NC	No connection (For AUO test only.Do not connect)
27	NC	No connection (For AUO test only.Do not connect)
28	VDD	+5.0V Power Supply
29	VDD	+5.0V Power Supply
30	VDD	+5.0V Power Supply

2.3 Electrical characteristics

2.3.1 Absolute Maximum Rating

Permanent damage may occur if exceeding the following maximum rating.

Symbol	Description	Min.	Max.	Unit.	Remark
VDD	Power Supply Input Voltage	GND-0.3	6.0	[Volt]	Ta=25°C

2.3.2 Recommended Operating Condition

Symble	Description	Min.	Typ.	Max.	Unit	Remark
VDD	Power Supply Input Voltage	4.5	5.0	5.5	[Volt]	
IDD	Power Supply Input Current	-	0.93	1.22	[A]	VDD=5V, white Pattern,FV= 60Hz
			1.22	1.46	[A]	VDD=5V, white Pattern,FV= 75Hz
IRush	Input Current	-	-	3.0	[A]	Note 3-1
PDD	VDD Power Consumption	-	4.65	6.1	[Watt]	VDD=5V, white Pattern,FV= 60Hz
			6.10	7.30	[Watt]	VDD=5V, white Pattern,FV= 70Hz
VDDrp	Allowable VDD Ripple Voltage	-	-	500	[mV]	VDD=5V, white Pattern,FV= 75Hz

Note 3-1: Inrush Current measurement

Test circuit:

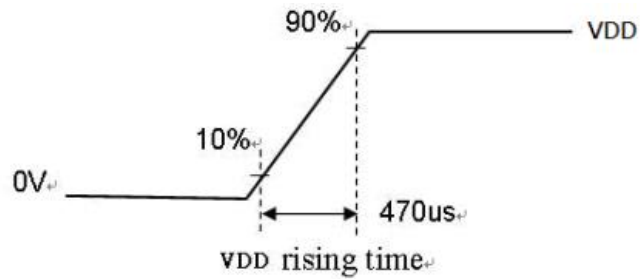
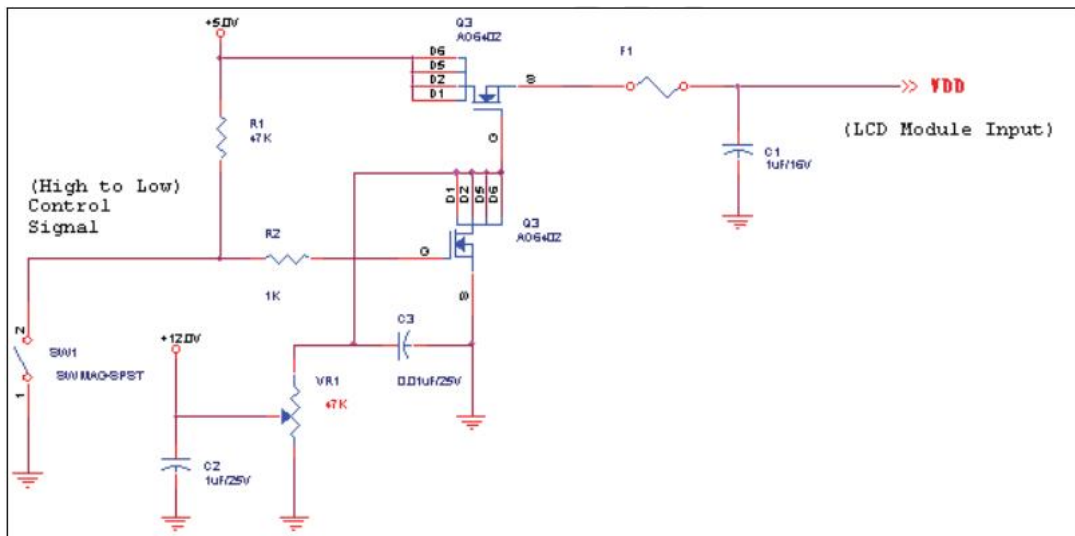

The duration of VDD rising time: 470us.

2.4 Signal Characteristics

2.4.1 LCD Pixel Format

	1	2	...	1919	1920								
1st Line	R	G	B	R	G	B	...	R	G	B	R	G	B

1200 Line	R	G	B	R	G	B	...	R	G	B	R	G	B

2.4.2 LVDS Data Format

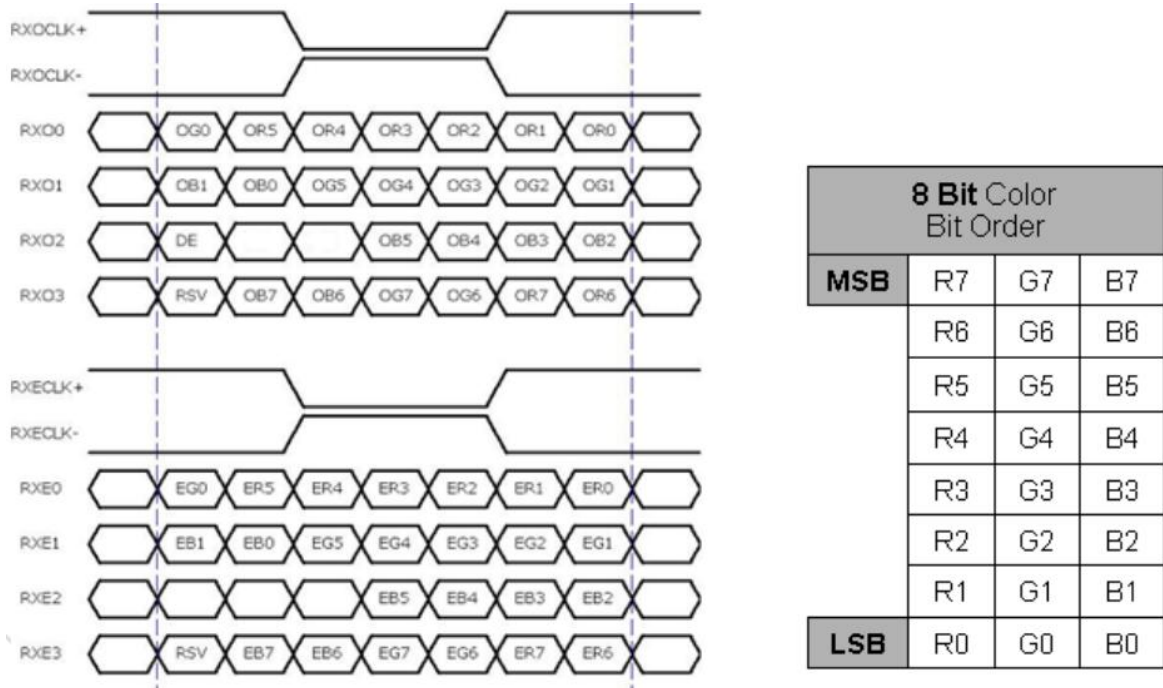

Note 3-2

a.O = “Odd Pixel Data”

E = “Even Pixel Data”

b.Refer to 2.4.1 LCD pixel format, the 1st data is I(Odd Pixel Data), the 2nd data is 2(Even Pixel Data) And the last data is I920(Even Pixel Data).

2.4.3 Color versus Input Data

The following table is for color versus input data(8bit).The higher the gray level,the brighter the color

Color		Data Signal																							
		RED								GREEN								BLUE							
		R7	R6	R5	R4	R3	R2	R1	R0	G7	G6	G5	G4	G3	G2	G1	G0	B7	B6	B5	B4	B3	B2	B1	B0
Basic Color	Black	0	0	0	0	0	0	0	0	0	0	0	0	0	0	0	0	0	0	0	0	0	0	0	0
	Red	1	1	1	1	1	1	1	1	0	0	0	0	0	0	0	0	0	0	0	0	0	0	0	0
	Green	0	0	0	0	0	0	0	0	1	1	1	1	1	1	1	1	0	0	0	0	0	0	0	0
	Cyan	0	0	0	0	0	0	0	0	1	1	1	1	1	1	1	1	1	1	1	1	1	1	1	1
	Magenta	1	1	1	1	1	1	1	1	0	0	0	0	0	0	0	0	1	1	1	1	1	1	1	1
	Blue	0	0	0	0	0	0	0	0	0	0	0	0	0	0	0	0	1	1	1	1	1	1	1	1
	Yellow	1	1	1	1	1	1	1	1	1	1	1	1	1	1	1	1	0	0	0	0	0	0	0	0
	White	1	1	1	1	1	1	1	1	1	1	1	1	1	1	1	1	1	1	1	1	1	1	1	1
Gray Scale of Red	Red(0) /	0	0	0	0	0	0	0	0	0	0	0	0	0	0	0	0	0	0	0	0	0	0	0	0
	Red(1)	0	0	0	0	0	0	0	1	0	0	0	0	0	0	0	0	0	0	0	0	0	0	0	0
	Red(2)	0	0	0	0	0	0	1	0	0	0	0	0	0	0	0	0	0	0	0	0	0	0	0	0
	△	↑								↑								↑							
	▽	↓								↓								↓							

	Red(253)	1	1	1	1	1	1	0	1	0	0	0	0	0	0	0	0	0	0	0	0	0	0	0	0	
	Red(254)	1	1	1	1	1	1	1	0	0	0	0	0	0	0	0	0	0	0	0	0	0	0	0	0	
	Red(255)	1	1	1	1	1	1	1	1	0	0	0	0	0	0	0	0	0	0	0	0	0	0	0	0	
Gray Scale of Green	Green(0) /	0	0	0	0	0	0	0	0	0	0	0	0	0	0	0	0	0	0	0	0	0	0	0	0	
	Green(1)	0	0	0	0	0	0	0	0	0	0	0	0	0	0	0	1	0	0	0	0	0	0	0	0	
	Green(2)	0	0	0	0	0	0	0	0	0	0	0	0	0	0	1	0	0	0	0	0	0	0	0	0	
	△	↑							↑							↑										
	▽	↓							↓							↓										
	Green(253)	0	0	0	0	0	0	0	0	1	1	1	1	1	1	0	1	0	0	0	0	0	0	0	0	0
	Green(254)	0	0	0	0	0	0	0	0	1	1	1	1	1	1	1	0	0	0	0	0	0	0	0	0	0
Green(255)	0	0	0	0	0	0	0	0	1	1	1	1	1	1	1	1	0	0	0	0	0	0	0	0	0	
Gray Scale of Blue	Blue(0) /	0	0	0	0	0	0	0	0	0	0	0	0	0	0	0	0	0	0	0	0	0	0	0	0	
	Blue(1)	0	0	0	0	0	0	0	0	0	0	0	0	0	0	0	0	0	0	0	0	0	0	0	1	
	Blue(2)	0	0	0	0	0	0	0	0	0	0	0	0	0	0	0	0	0	0	0	0	0	0	1	0	
	△	↑							↑							↑										
	▽	↓							↓							↓										
	Blue(253)	0	0	0	0	0	0	0	0	0	0	0	0	0	0	0	0	1	1	1	1	1	1	1	0	1
	Blue(254)	0	0	0	0	0	0	0	0	0	0	0	0	0	0	0	0	1	1	1	1	1	1	1	1	0
Blue(255)	0	0	0	0	0	0	0	0	0	0	0	0	0	0	0	0	1	1	1	1	1	1	1	1	1	

2.4.4 LVDS Specification

DC Characteristics:

Symbol	Description	Min	Typ	Max	Units	Condition
V_{TH}	LVDS Differential Input High Threshold	-	-	+10 0	[mV]	$V_{CM}=1.2V$
V_{TL}	LVDS Differential Input High Threshold	-100	-	-	[mV]	$V_{CM}=1.2V$
$ V_{ID} $	LVDS Differential Input High Voltage	100	-	600	[mV]	
V_{CM}	LVDS Common Mode Voltage	+1.0	+1.2	+1.5	[V]	$V_{TH}-V_{TL}=200mV$

3. Backlight Unit

3.1 Block Diagram

The following shows the block diagram of the 27 inch Backlight Unit, And it includes 108(4014) pcs LED in the LED lightbar.(6 strings and 18 pcs LED one string).

3.1.1 Recommended Operating Condition

(Ta=25°C)

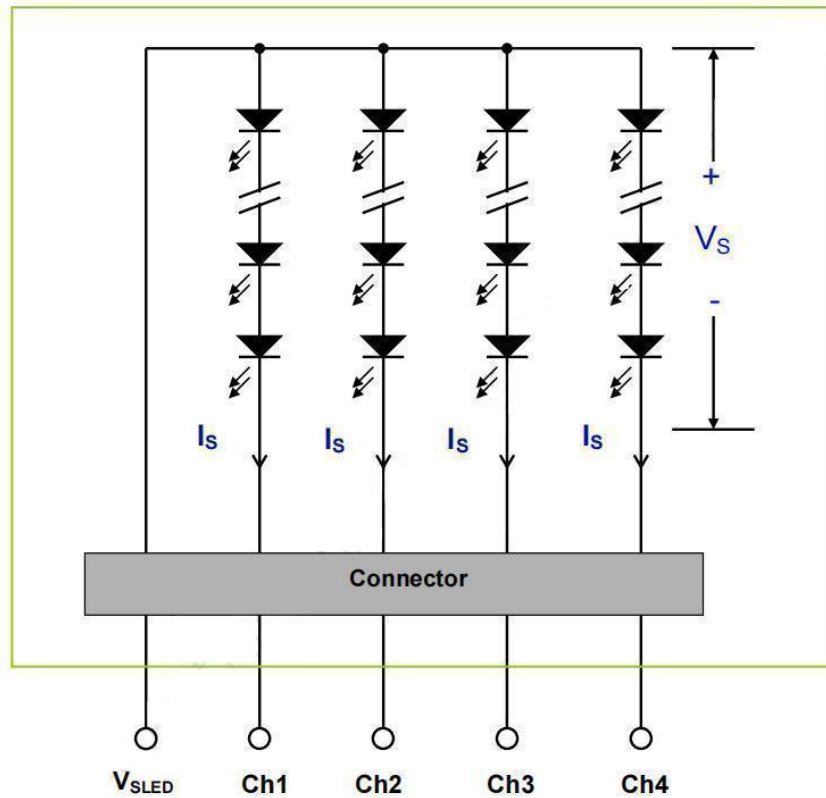

Item	Symbol	Min.	Typ.	Max.	Unit
LED operation Voltage	V_{led}	52.2	-	63	V
LED operation Current	I_{led}	-	440	-	mA
Backlight Power	P_{BL}	22.97	-	27.72	W
Luminance	L	400	500		nit
LED Life Time		30000			Hrs
Luminance uniformity	ΔL	75	80		%

3.2 Interface Connection

3.2.1 Connector Type

Backlight Connector	Manufacturer	ENTERY
	Part Number	3707K-S06N-21R
Mating Connector	Manufacturer	ENTERY
	Part Number	HII2K-P06N-13B(Non-Locking type) HII2K-P06N-13B(Locking type)

3.3 Backlight Electrical / Optical Characteristics

Backlight Connector dimension:

H x V x D= 13.9 x 3.00 x 4.25, Pitch=1.0(unit=mm)

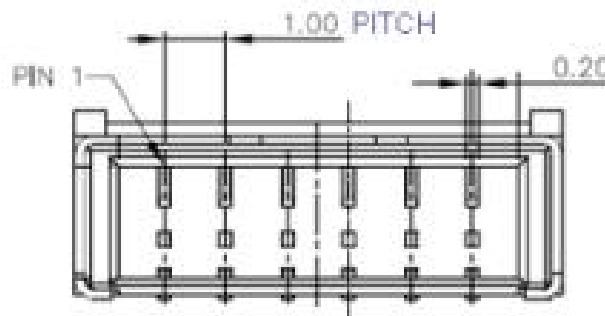

Pin#	Symbol	Description	Remark
1	Ch1	LED Current Feedback Terminal(Channel 1)	
2	Ch2	LED Current Feedback Terminal(Channel 2)	
3	V _{SLED}	LED Power Supply Voltage Input Terminal	
4	V _{SLED}	LED Power Supply Voltage Input Terminal	
5	Ch3	LED Current Feedback Terminal(Channel 3)	
6	Ch4	LED Current Feedback Terminal(Channel 4)	

4. Reliability Test

AUO reliability test items are listed ad following table.(Bare panel only)

Ltems	Condition	Remark
Temperature Humidity Bias(THB)	Ta= 50°C , 80%RH, 300huurs	
High Temperature Operation(HTO)	Ta= 50°C , 50%RH, 300huurs	
Low Temperature Operation(LTO)	Ta= 0°C , 300huurs	
High Temperature Storage (HTS)	Ta= 60°C , 300huurs	
Low Temperature Storage (LTS)	Ta= -20°C , 300huurs	
Vibration Test (Non-operation)	Acceleration: 1.5 Grms Wave: Random Frequency:10-200 Hz Sweep:30 Minutes each Axis (X,Y,Z)	
Shock Test (Non-operation)	Acceleration: 50Grms Wave: Half-sine Active TIMIE: 20ms Direction: ±X,±Y,±Z(one time for each Axis)	
Thermal Shock Test(TST)	-20°C/30min, 60°C/30min,100 cycles	
On/Off Test	On/10sec,Off/10sec,30,000 cycles	Note 4-1
ESD(Elector Static Dishcharge)	Contact Discharge:± 15KV , 150pF(330Ω) 1sec, 8 points, 25 times/point	Note 4-2
	Air Discharge:± 15KV , 150pF(330Ω) 1sec, 8 points, 25 times/point	
Altitude Test	Operation:18,000 ft Non-Operation:40,000ft	

Note 4-1 a. A cycle of rapid temperature change consists of varying the temperature fron -20°C to 60°C ,
And back again. Power is not applied during the test.

b. After finish temperature cycling, the unit is placed in normal room ambient for at least 4 hours
before power on.

Note 4-2 EN61000-4-2,ESD class B: Certain performance degradtion allowed

No data lost

Self-recoverable

No hardware failures.

ESD discharged points should avoid display area and periphery front bezel of display area. Suggest points were 4 side parallel edge of display area surface. Metal front bezel must cover half area of BM (black matrix), and metal front bezel must connect with metal back bezel to protect source IC of panel by ESD damaged.

5. Shipping Label

The label is on the panel as shown below

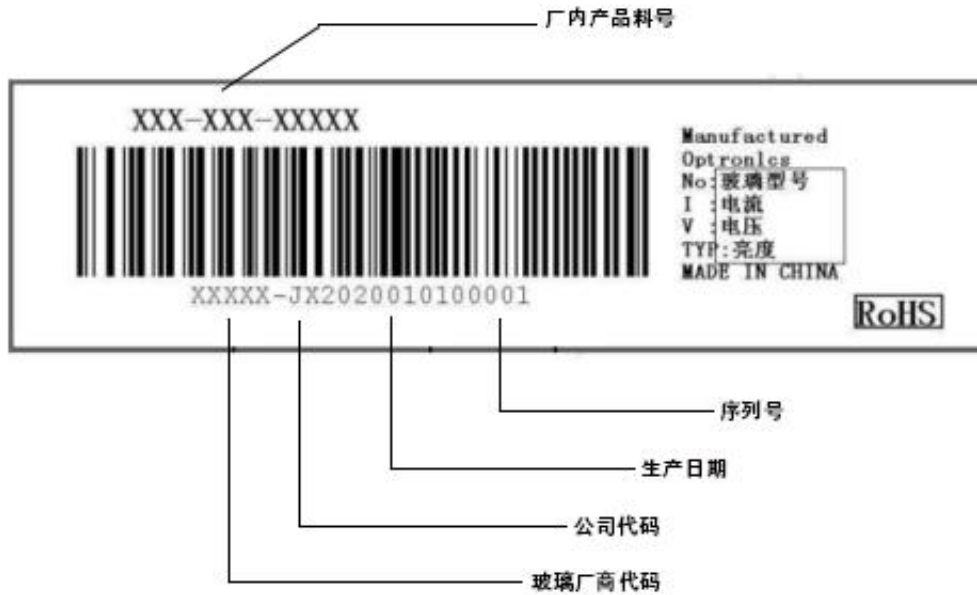

Parameter	Packing box	Unit
Size	670(L)282(W)x412(H)(typ.)	mm
Weight	3.1(typ.)	Kg
Total weight	31(typ.) (with 10 products)	Kg

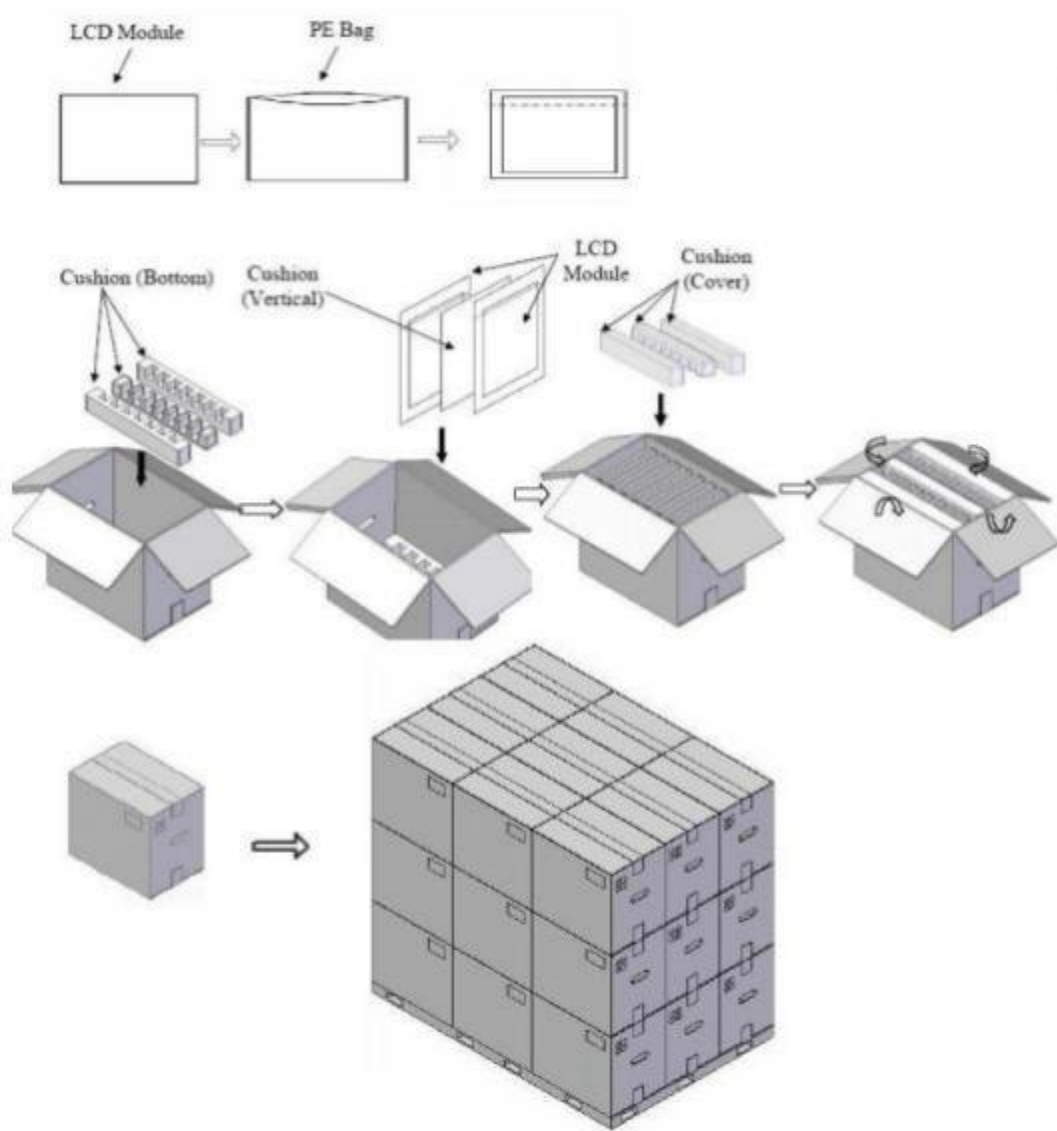

6. Precaution

6.1 assembly and handling precautions

1. Do not apply rough force such as bending or twisting to the module during assembly.
2. To assemble or install module into user's system can be in clean working areas. The dust and oil may cause electrical short or worsen the polarizer.
3. It's not permitted to have pressure or impulse on the module because the LCD panel and Backlight will be damaged.
4. Always follow the correct power sequence when LCD module is connecting and operating. This can prevent damage to the CMOS LSI chips during latch-up.
5. Do not pull the I/F connector in or out while the module is operating .
6. Do not disassemble the module. Use a soft dry cloth without chemicals for cleaning, because the surface of polarizer is very soft and easily scratched.
7. It is dangerous that moisture come into or contacted the LCD module, because moisture may damage LCD module when it is operating.

8. High temperature or humidity may reduce the performance of module. Please store LCD module within the specified storage conditions.
9. When ambient temperature is lower than 10 °C may reduce the display quality. For example, the response time will become slowly.

6.2 Safety precautions

1. It is dangerous that moisture come into or contacted the LCD module, because the moisture may damage LCD module when it is operating.
2. If the liquid crystal material leaks from the panel, it should be kept away from the eyes or mouth, in case of contact with hands, skin or clothes, it has to be washed away thoroughly with soap.
3. After the module's end of life, it is not harmful in case of normal operation and storage.

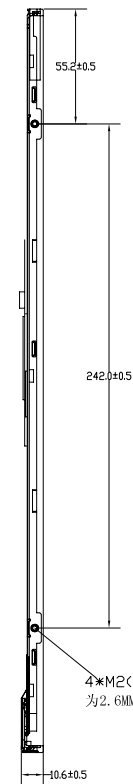
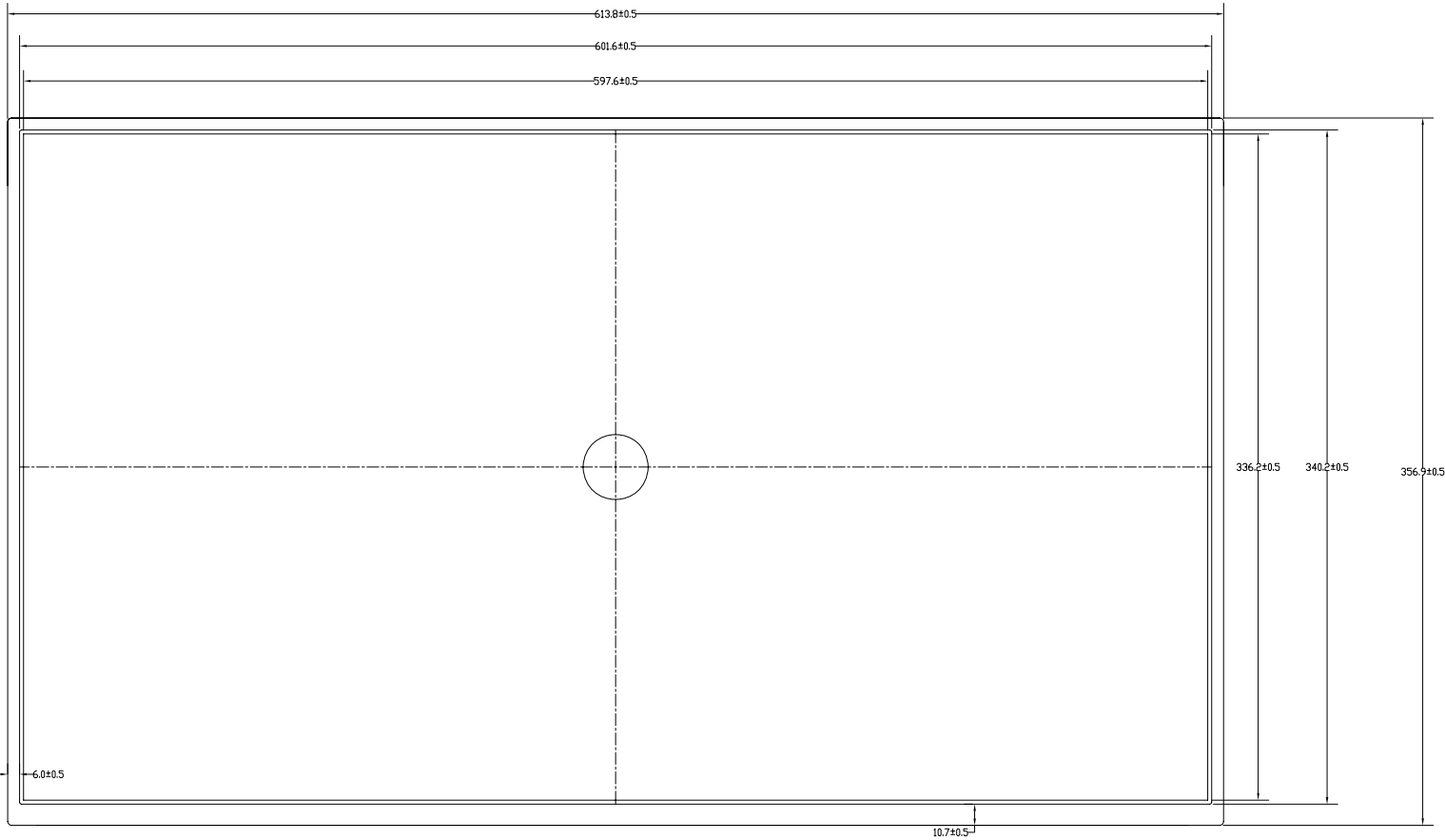

4*M2(螺柱长度为2.6MM)



