

CUSTOMER APPROVE

SPECIFICATION

FOR

DOUBLE LIN TFT-LCD MODULE

Edition : Preliminary spec 1.0

Date of issue : 2022-05-03

Product No. : T215HVN01.1

APPROVED	CHECKED	PREPARED
Wei Yan	ZhongCai Liang	YongHeng Jia

Revision History

Date	Rev.	Page	Old Description	New Description	Remark
2022-05-03	1.0	All	The specification was first issued		

CONTENTS

目录

SPECIFICATION -----	1
DOUBLE LIN TFT-LCD MODULE -----	1
Revision History -----	2
CONTENTS -----	3
1.General Description -----	4
1.1.Display Characteristics -----	4
1.2 Absolute Maximum Rating of Environment -----	5
1.3.Optical Characteristics -----	6
2. TFT-LCD Module -----	10
2.1.Block Diagram -----	10
2.2 Interface Connection -----	10
2.3Electrical characteristics -----	12
3 Backlight Unit -----	13
3.1Connector Type -----	13
3.2 Electrical Characteristics -----	14
4 Reliability Test -----	14
5.Shipping Label -----	15
6.Precaution -----	16
6.1 Assembly and handling precautions -----	16
6.2 Safety precautions -----	17

1.General Description

This specification applies to the 21.5inch wide Color a-Si TFT-LCD Module T215HVN01.1. The display supports the Full HD -1920(H) x 1080(V) screen format and 16.7M colors (8 bits RGB data input). The input interface is Dual channel LVDS and this module doesn't contain a driver board for backlights.

1.1.Display Characteristics

The following items are characteristics summary on the table under 25°C condition:

ITEMS	Unit	SPECIFICATIONS
Screen Dingonal	[mm]	546.86(21.53")
Active Area	[mm]	476.64 (H) ×268.11 (V)
Pixels H x V	-	1920 x 3(RGB)×1080
Pixels Pitch	[um]	248.25(per one triad) × 248.25
Pixels Arrangement	-	R.G.B. Vertical Stripe
Display Mode	-	VA Mode,Nomrally Black
White Luminance(Center)	[cd/m ²]	750 (Typ.)
Contrast Ratio	-	3000 (Typ.)
Response Time	[msec]	18ms (Typ.on/off)
Viewing Angle	[degree]	89/89/89/89
Outline Dimension	[mm]	495.6(H) x 292.4(V) x 10.5(D) (Typ.)
Electrical Interface	-	Dual Channel LVDS
Support Color		16.7M colors (RGB 6 - bits +Hi - FRC data)
Surface Treatment		Anti - glare type, Hardness 3H
Temperature Range Operating Storage(Shipping)	[oC] [oC]	0 to +50°C -20 to+60°C

1.2 Absolute Maximum Rating of Environment

Permanent damage may occur if exceeding the following maximum rating.

Symbol	Description	Min.	Max.	Unit	Remark
TOP	Operating Temperature	0	+50	[°C]	Note 2-1
TGS	Glass surface temperature	0	+65	[°C]	Note 2-1 Function judged only
HOP	Operation Humidity	5	90	[%RH]	Note 2-1
TST	Storage Temperature	-20	+60	[°C]	
HST	Storage Humidity	5	90	[%RH]	

Note 2-1 : Temperature and relative humidity range are shown as the below figure.

1. 90% RH Max ($T_a \leq 39^\circ\text{C}$)
2. Max wet-bulb temperature at 39°C or less. ($T_a \leq 39^\circ\text{C}$)
3. No condensation

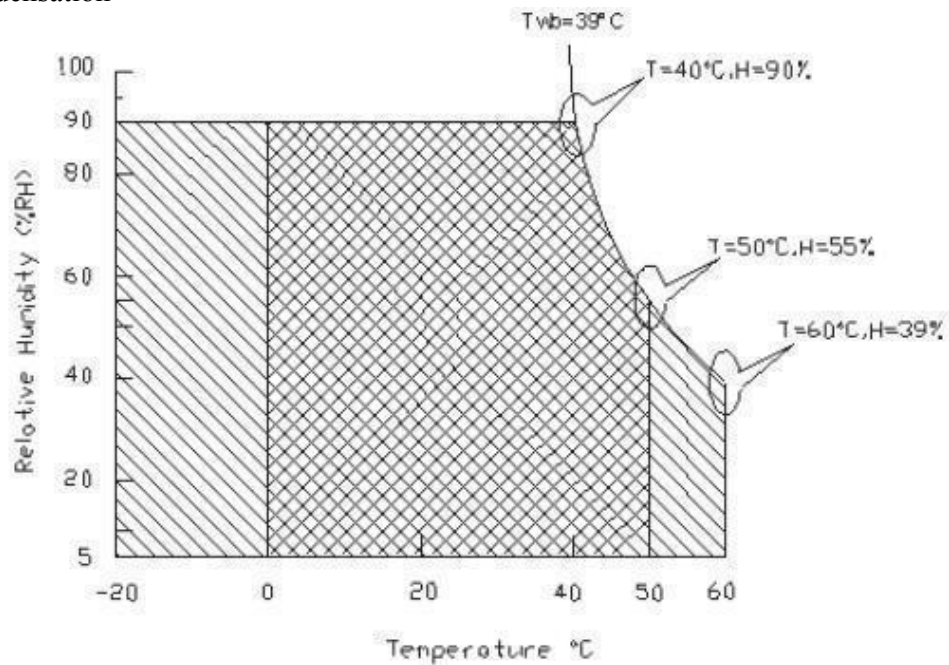

Operating Range



Storage Range

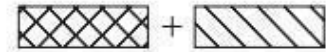

1.3.Optical Characteristics

The optical characteristics are measured on the following test condition.

Test Condition:

1. Equipment setup: Please refer to *Note 2 - 2*.
2. Panel Lighting time: 30 minutes
3. VDD=5.0V, Fv=60Hz, Is=60mA, Ta=25°C

Symbol	Description		Min.	Typ.	Max.	Unit	Remark		
Lw	White Luminance (Center of screen)		600	750	-	[cd/m2]	Note 2 - 2 By SR - 3		
Luni	Luminance Uniformity (9 points)		75	80	-	%	Note 2 - 3 By SR - 3		
Crr	Contrast Ratio (Center of screen)		2000	3000	-	-	Note 2 - 4 By SR - 3		
θR	Horizontal Viewing Angle (CR=10)	Right	75	89	-	[degree]	Note 2 - 5 By SR - 3		
θL		Left	75	89	-				
ΦH	Vertical Viewing Angle (CR=10)	Up	75	89	-				
ΦL		Down	75	89	-				
θR	Horizontal Viewing Angle (CR=5)	Right	75	89	-				
θL		Left	75	89	-				
ΦH	Vertical Viewing Angle (CR=5)	Up	75	89	-				
ΦL		Down	75	89	-				
TR	Response Time	Rising Time	-	13	28			[msec]	Note 2 - 6 By TRD - 100
TF		Falling Time	-	5	8				
-		Rising + Falling	-	18	36				
Rx	Color Coordinates (CIE 1931)	Red x	0.610	0.640	0.670	-	By SR - 3		
Ry		Red y	0.314	0.344	0.374				
Gx		Green x	0.266	0.296	0.326				
Gy		Green y	0.619	0.649	0.679				
Bx		Blue x	0.112	0.142	0.172				
By		Blue y	0.051	0.081	0.111				
Wx		White x	0.250	0.280	0.310				
Wy		White y	0.326	0.356	0.386				
NTSC Area Ratio				72		[%]	By SR-3		
CT	Crosstalk		-	-	1.5	[%]	Note 2 - 7 By SR - 3		
FdB	Flicker (Center of screen)		-	-	-20	[dB]	Note 2 - 8 By SR - 3		

Note2-2:Equipment setup

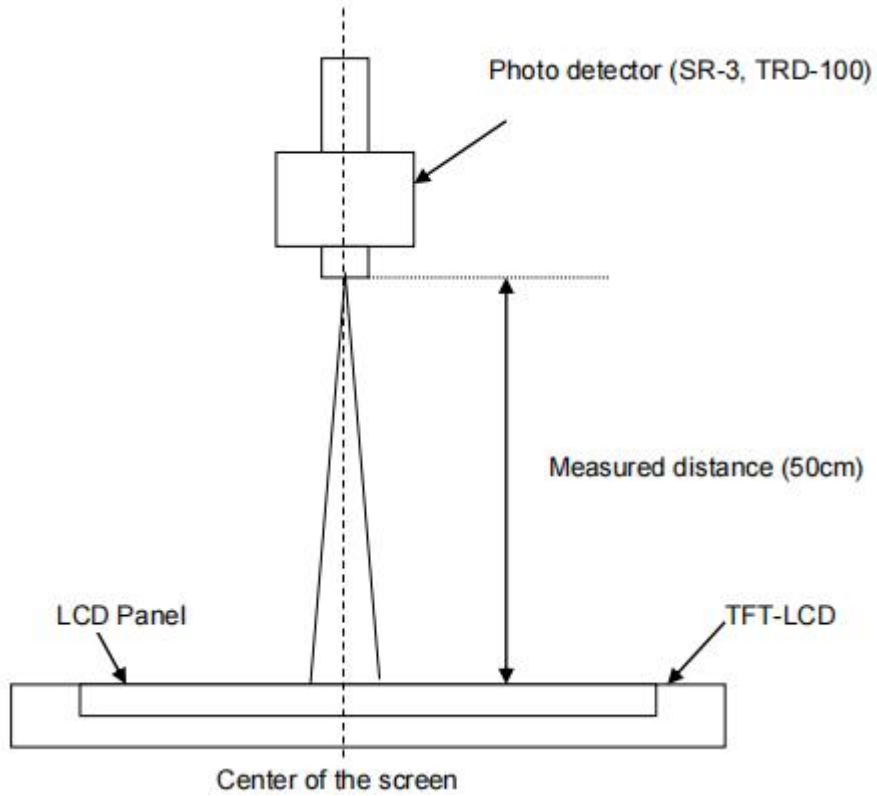

Note 2-3: Luminance Uniformity Measurement

Definition:

$$\text{Luminance Uniformity} = \frac{\text{Minimum Luminance of 9Points(P1~P9)}}{\text{Maximum Luminance of 9Points(P1~P9)}}$$

a. Test pattern: White Pattern

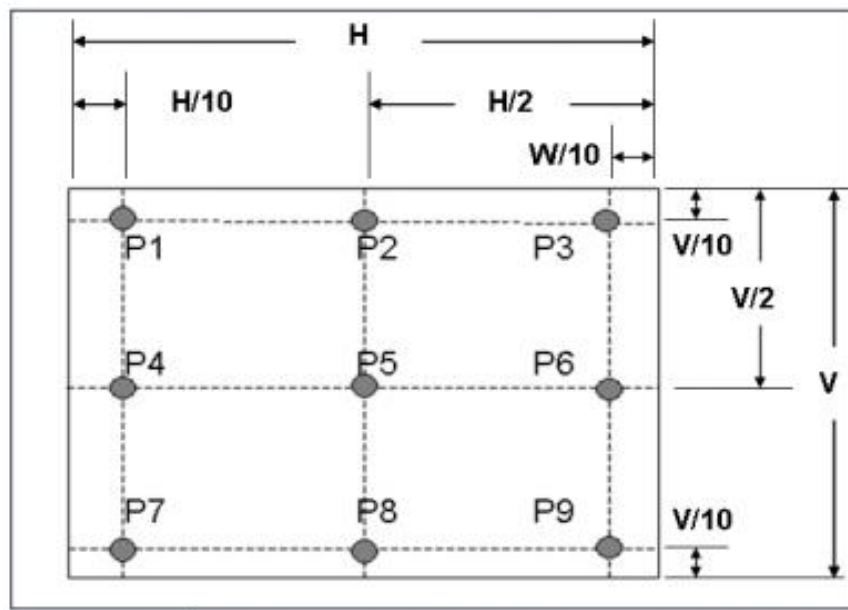

Note 2-4: Contrast Ratio Measurement

Definition:

$$\text{Contrast Ratio} = \frac{\text{Luminance of White pattern}}{\text{Luminance of Black pattern}}$$

- a. Measured position: Center of screen (P5) & perpendicular to the screen ($\theta = \Phi = 0^\circ$)

Note 2-5: Viewing angle measurement

Definition: The angle at which the contrast ratio is greater than 10 & 5.

- a. Horizontal view angle: Divide to left & right (θ_L & θ_R)

Vertical view angle: Divide to up & down (Φ_H & Φ_L)

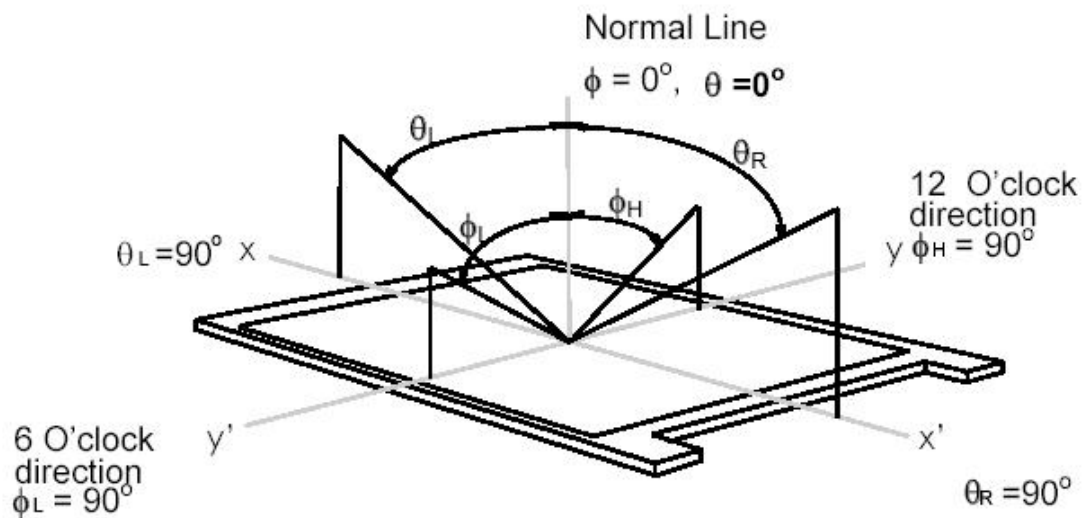

Note 2-6: Response time measurement

The output signals of photo detector are measured when the input signals are changed from “Black” to “White” (rising time, T_R), and from “White” to “Black” (falling time, T_F), respectively. The response time is interval between the 10% and 90% of optical response. (Black & White color definition: Please refer section 3.4.3)

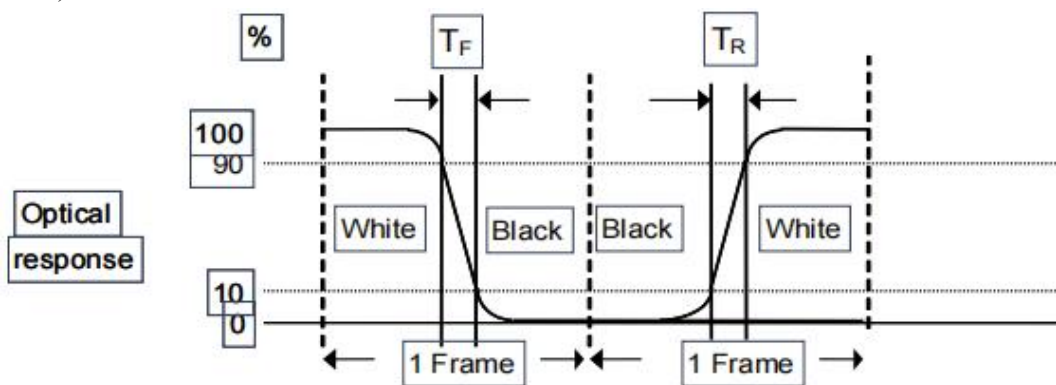

Note 2-7: Crosstalk measurement

Definition:

$$CT = \text{Max. } (CT_H, CT_V);$$

Where

a. Maximum Horizontal Crosstalk :

$$CT_H = \text{Max. } (| Y_{BL} - Y_{AL} | / Y_{AL} \times 100 \%, | Y_{BR} - Y_{AR} | / Y_{AR} \times 100 \%);$$

Maximum Vertical Crosstalk:

$$CT_V = \text{Max. } (| Y_{BU} - Y_{AU} | / Y_{AU} \times 100\%, | Y_{BD} - Y_{AD} | / Y_{AD} \times 100 \%);$$

b. $Y_{AU}, Y_{AD}, Y_{AL}, Y_{AR}$ = Luminance of measured location without Black pattern

$Y_{BU}, Y_{BD}, Y_{BL}, Y_{BR}$ = Luminance of measured location with Black pattern

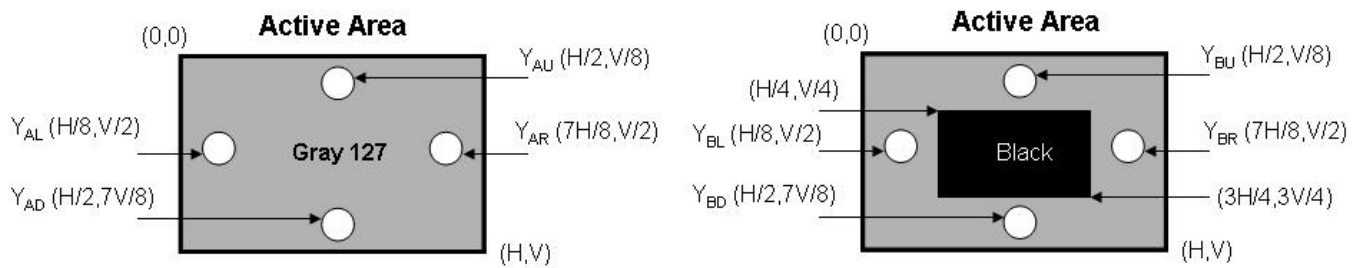

Note 2-8: Flicker measurement

a. Test pattern: It is listed as following.

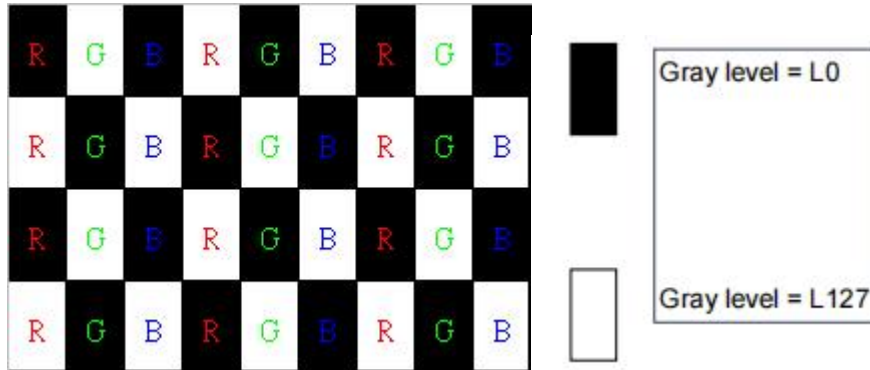

R: Red, G: Green, B:Blue

b. Measured position: Center of screen (P5) & perpendicular to the screen

($\theta = \Phi = 0^\circ$)

2. TFT-LCD Module

2.1. Block Diagram

The following shows the block diagram of the 21.5inch Color TFT-LCD Module.

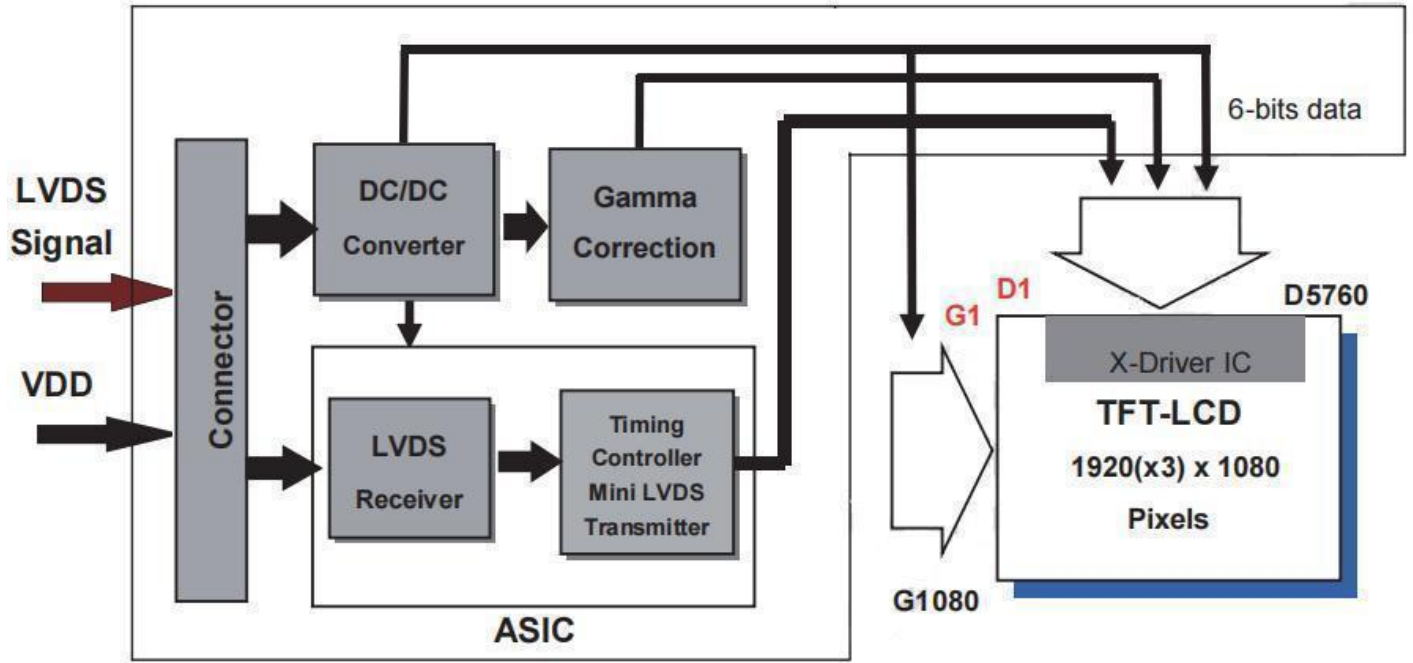

2.2 Interface Connection

2.2.1 Connector Type

TFT-LCD Connector	Manufacturer	P-TWO	STM
	Part Number	AL230F-A0G1D-P	MSCKT2407P30HB
Mating Connector	Manufacture	JAE	
	Part Number	FI-X30HL (Locked Type)	

2.2.2 LCD Connector Pin Assignment

PIN#	SIGNAL NAME	DESCRIPTION
1	RxOIN0-	Negative LDVS differential data input (Odd data)
2	RxOIN0+	Positive LDVS differential data input (Odd data)
3	RxOIN1-	Negative LDVS differential data input (Odd data)
4	RxOIN1+	Positive LDVS differential data input (Odd data)
5	RxOIN2-	Negative LDVS differential data input (Odd data)
6	RxOIN2+	Positive LDVS differential data input (Odd data)
7	GND	Power Ground
8	RxOCLKIN-	Negative LDVS differential data input (Odd clock)
9	RxOCLKIN+	Positive LDVS differential data input (Odd clock)
10	RxOIN3-	Negative LDVS differential data input (Odd data)
11	RxOIN3+	Positive LDVS differential data input (Odd data)
12	RxEIN0-	Negative LDVS differential data input (Even data)
13	RxEIN0+	Positive LDVS differential data input (Even data)
14	GND	Power Ground
15	RxEIN1-	Negative LDVS differential data input (Even data)
16	RxEIN1+	Positive LDVS differential data input (Even data)
17	GND	Power Ground
18	RxEIN2-	Negative LDVS differential data input (Even data)
19	RxEIN2+	Positive LDVS differential data input (Even data)
20	RXECLKIN-	Negative LDVS differential data input (Even clock)
21	RXECLKIN+	Positive LDVS differential data input (Even clock)
22	RxEIN3-	Negative LDVS differential data input (Even data)
23	RxEIN3+	Positive LDVS differential data input (Even data)
24	GND	Power Ground
25	NC	No connection (For AUO test only.Do not connect)
26	NC	No connection (For AUO test only.Do not connect)
27	NC	No connection (For AUO test only.Do not connect)
28	VDD	Power Supply Input Voltage
29	VDD	Power Supply Input Voltage
30	VDD	Power Supply Input Voltage

2.3 Electrical characteristics

2.3.1 Absolute Maximum Rating

Permanent damage may occur if exceeding the following maximum rating.

Symbol	Description	Min.	Max.	Unit.	Remark
VDD	Power Supply Input Voltage	GND-0.3	6.0	[Volt]	Ta=25°C

2.3.2 Recommended Operating Condition

Symble	Description	Min.	Typ.	Max.	Unit	Remark
VDD	Power Supply Input Voltage	4.5	5.0	5.5	[Volt]	
IDD	Power Supply Input Current	-	0.62	0.74	[A]	VDD=5V, ALL white Pattern,FV= 60Hz
		-	0.7	0.84	[A]	VDD=5V, ALL white Pattern,FV= 75Hz
IRush	Input Current	-		5	[A]	Note 3-1
PDD	VDD Power Consumption	-	3.1	3.7	[Watt]	VDD=5V, ALL white Pattern,FV= 60Hz
		-	3.5	4.2	[Watt]	VDD=5V, ALL white Pattern,FV= 70Hz
VDDrp	Allowable Logic/LCD Drive Ripple Voltage	-	-	500	[mV]	VDD=5V, ALL white Pattern,FV= 75Hz

Note 3-1: Inrush Current measurement

Test circuit:

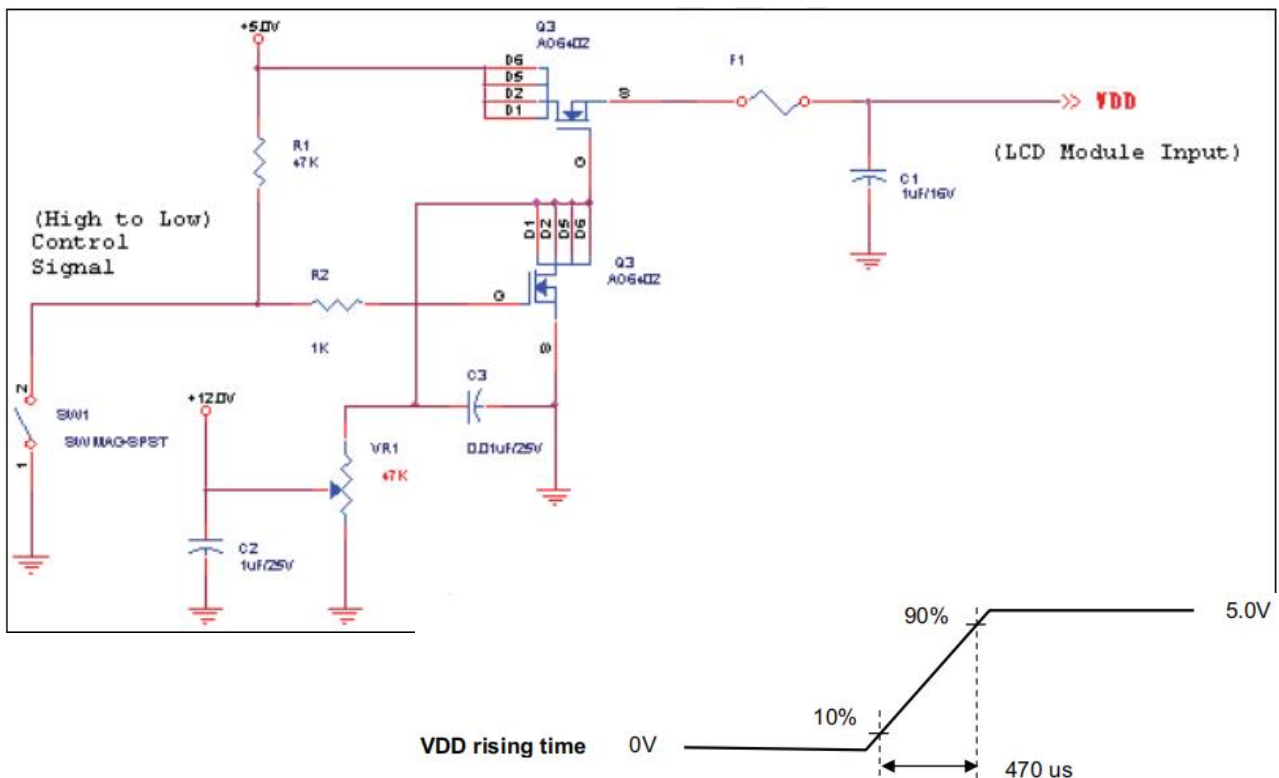

3 Backlight Unit

3.1 Connector Type

This connector is mounted on LED light-bar.

Connector Name / Designation	Driver Board Connector
Manufacturer	-
Type Part Number	-
Mating Type Part Number (Housing)	-

Backlight Connector dimension

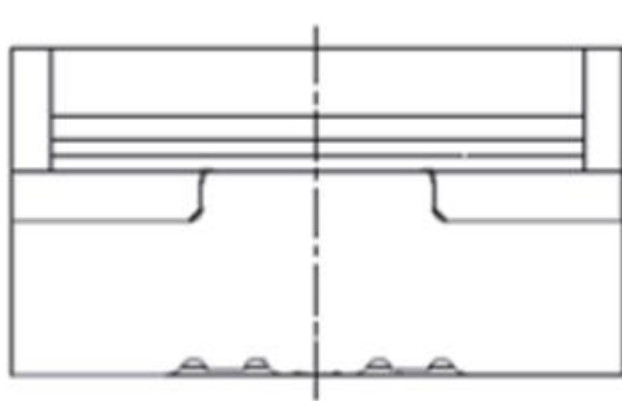

it includes 72(4014) pcsLED in the LED light bar.(4 strings and 18 pcs LED of one string)

connector CN2 : PH- 2P *2

Pin#	Signal Name
1	Positive Pole
2	Negative Pole



3.2 Electrical Characteristics

3.2.1 Recommended Operating Condition

(Ta=25°C)

Item	Symbol	Min.	Typ.	Max.	Unit
LED operation Voltage	V led	50.4	-	61.2	V
LED operation Current	I led	-	480	-	mA
Backlight Power	P _{BL}	24.19	-	29.37	W
Luminance	L	600	750		nit
LED Life Time		30000			Hrs
Luminance uniformity	ΔL	75	80		%

4 Reliability Test

AUO reliability test items are listed as following table.(Bare panel only)

Items	Condition	Remark
Temperature Humidity Bias (THB)	Ta= 50°C, 80%RH, 300hours	
High Temperature Operation (HTO)	Ta= 50°C, 50%RH, 300hours	
Low Temperature Operation (LTO)	Ta= 0°C, 300hours	
High Temperature Storage (HTS)	Ta= 60°C, 300hours	
Low Temperature Storage (LTS)	Ta= -20°C, 300hours	
Vibration Test (Non-operation)	Acceleration: 1.5 Grms Wave: Random Frequency: 10-200 Hz Sweep: 30 Minutes each Axis (X,Y,Z)	
Shock Test (Non-operation)	Acceleration: 50 Grms Wave: Half-sine Active TIME: 20ms Direction: ±X,±Y,±Z (one time for each Axis)	
Thermal Shock Test (TST)	-20°C/30min, 60°C/30min, 100 cycles	
On/Off Test	On/10sec, Off/10sec, 30,000 cycles	Note 4-1
ESD (Electro Static Discharge)	Contact Discharge: ± 15KV, 150pF(330Ω) 1sec, 8 points, 25 times/point	Note 4-2
	Air Discharge: ± 15KV, 150pF(330Ω) 1sec, 8 points, 25 times/point	
Altitude Test	Operation: 18,000 ft Non-Operation: 40,000ft	

- Note 4-1 a. A cycle of rapid temperature change consists of varying the temperature from -20°C to 60°C, And back again. Power is not applied during the test.
- b. After finish temperature cycling, the unit is placed in normal room ambient for at least 4 hours before power on.

Note 4-2 EN61000-4-2,ESD class B: Certain performance degradation allowed
 No data lost
 Self-recoverable
 No hardware failures.

5.Shipping Label

The label is on the panel as shown below

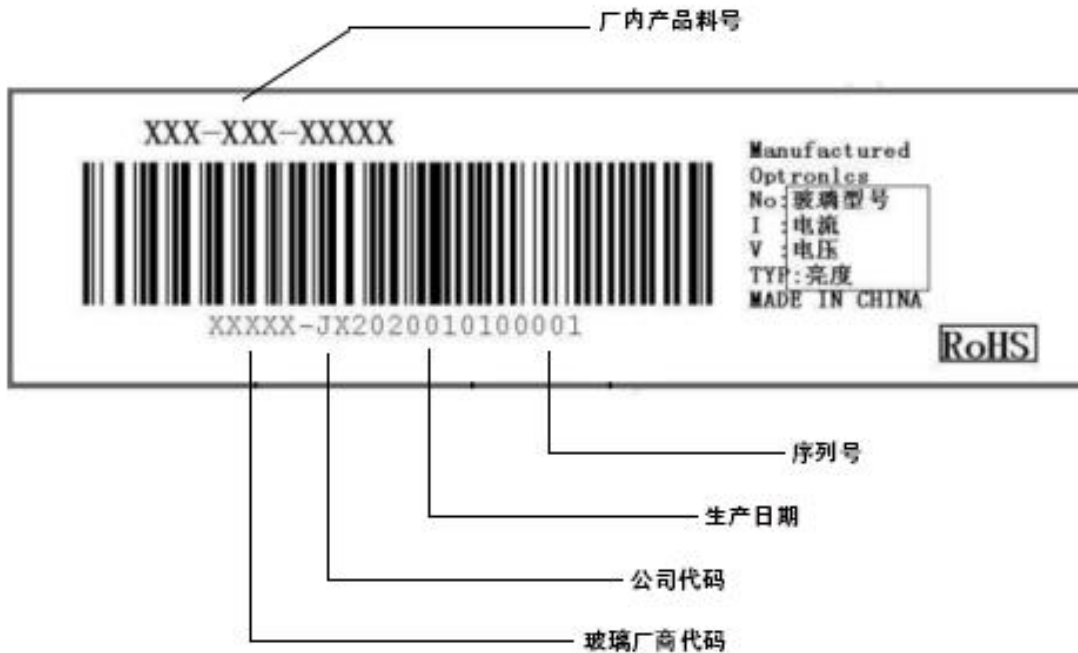

Parameter	Packing box	Unit
Size	555(L)x275(W)x345(H)(typ.)	mm
Weight	1.47(typ.)	Kg
Total weight	14.7(typ.) (with 10 products)	Kg

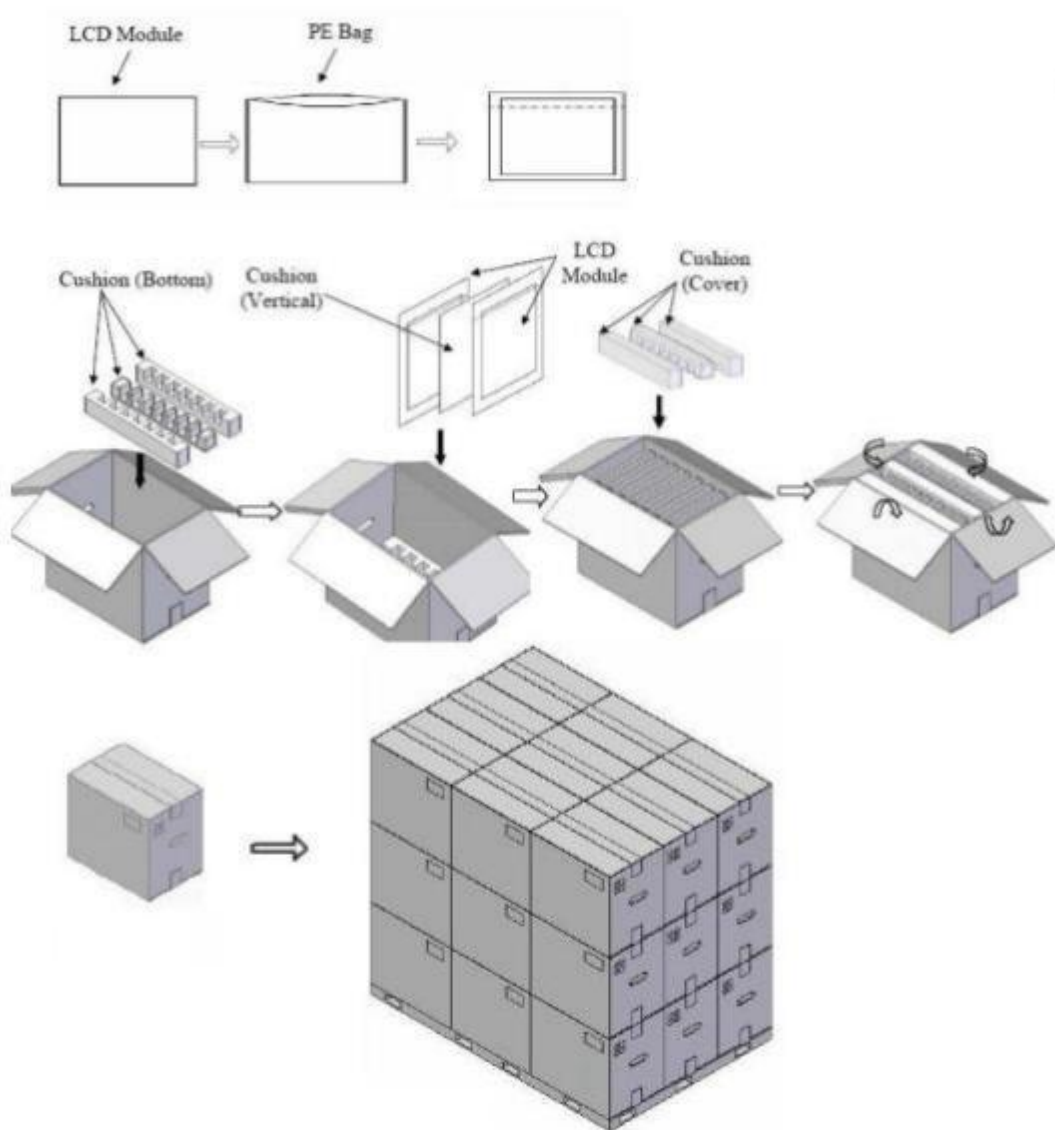

6. Precaution

6.1 Assembly and handling precautions

1. Do not apply rough force such as bending or twisting to the module during assembly.
2. To assemble or install module into user's system can be in clean working areas. The dust and oil may cause electrical short or worsen the polarizer.
3. It's not permitted to have pressure or impulse on the module because the LCD panel and Backlight will be damaged.
4. Always follow the correct power sequence when LCD module is connecting and operating. This can prevent damage to the CMOS LSI chips during latch-up.
5. Do not pull the I/F connector in or out while the module is operating.
6. Do not disassemble the module. Use a soft dry cloth without chemicals for cleaning, because the surface of polarizer is very soft and easily scratched.
7. It is dangerous that moisture come into or contacted the LCD module, because moisture may damage LCD module when it is operating.
8. High temperature or humidity may reduce the performance of module. Please store LCD module within the specified storage conditions.

9. When ambient temperature is lower than 10 °C may reduce the display quality. For example, the response time will become slowly.

6.2 Safety precautions

1. It is dangerous that moisture come into or contacted the LCD module, because the moisture may damage LCD module when it is operating.
2. If the liquid crystal material leaks from the panel, it should be kept away from the eyes or mouth, in case of contact with hands, skin or clothes, it has to be washed away thoroughly with soap.
3. After the module's end of life, it is not harmful in case of normal operation and storage.

Rev.	Description	Drawing By	Date	Approved

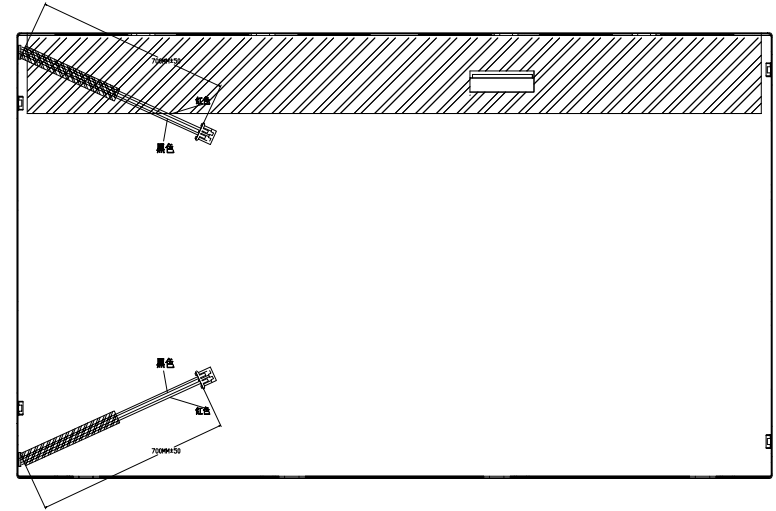
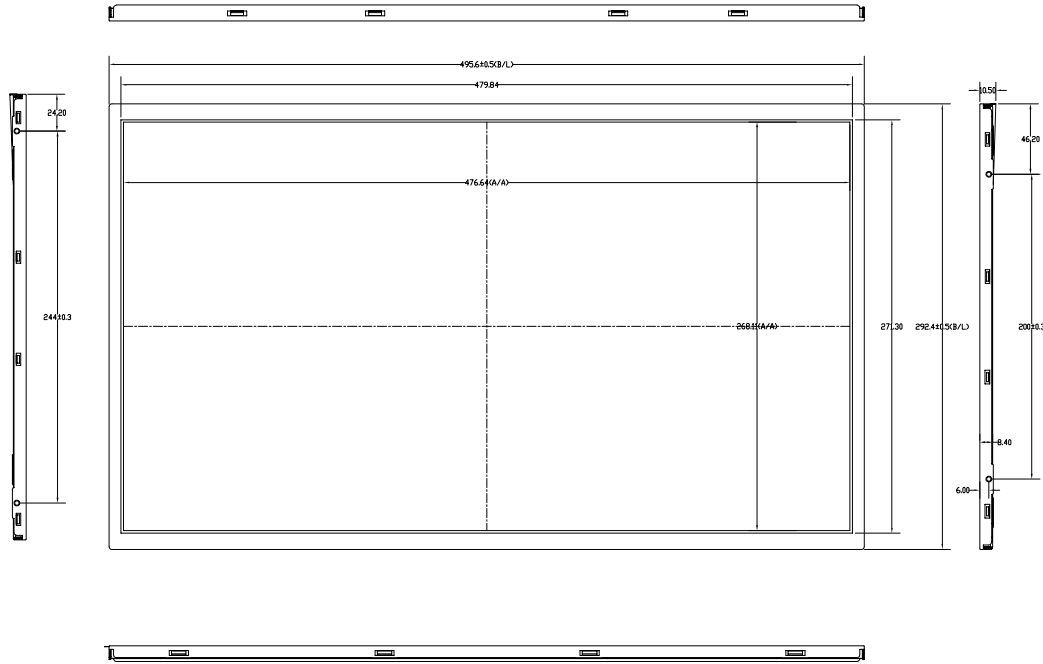

说明： 接口为2PIN. 第1 PIN(黑色) 为负极 第2 PIN (红色) 为正极

				PART Name	21.5寸LED 高亮组装屏			
				PART NO.				
Designer		Material		Sheet	1 OF 1	REV.	V1	
Drawing By		Scale	1:1	Unless otherwise specified Dimensions are in Tolerances		Third Angle Projection		
Checked By		Units	MM	Metric	Angles			
Approved By		Date	20100206	X.X ±0.2	+0.1			