

SPECIFICATION FOR APPROVAL

- () Preliminary Specification
- (●) Final Specification

Title	55.0" QWUXGA TFT LCD
-------	----------------------

BUYER	
SET MODEL	

SUPPLIER	Winmax display Co., Ltd.
*MODEL	WE550EQN-3N

APPROVED BY	SIGNATURE DATE
/	_____
/	_____
/	_____

APPROVED BY	SIGNATURE DATE

REVIEWED BY	_____

PREPARED BY	_____

Please return 1 copy for your confirmation with your signature and comments.

Winmax Display Co.,Ltd.

Product Specification

CONTENTS

Number	ITEM	Page
	COVER	0
	CONTENTS	1
	RECORD OF REVISIONS	2
1	GENERAL DESCRIPTION	3
2	ABSOLUTE MAXIMUM RATINGS	4
3	ELECTRICAL SPECIFICATIONS	5
3-1	ELECTRICAL CHARACTERISTICS	5
3-2	INTERFACE CONNECTIONS	7
3-3	SIGNAL TIMING SPECIFICATIONS	9
3-4	V by One SIGNAL SPECIFICATIONS	10
3-5	COLOR DATA REFERENCE	12
3-6	POWER SEQUENCE	13
4	OPTICAL SPECIFICATIONS	14
5	MECHANICAL CHARACTERISTICS	18
6	RELIABILITY	21
7	INTERNATIONAL STANDARDS	22
7-1	Safety	22
7-2	EMC	22
7-3	ENVIRONMENT	22
8	PACKING	23
8-1	INFORMATION OF LCM LABEL	23
8-2	PACKING FORM	23
9	PRECAUTIONS	24
9-1	MOUNTING PRECAUTIONS	24
9-2	OPERATING PRECAUTIONS	24
9-3	ELECTROSTATIC DISCHARGE CONTROL	25
9-4	PRECAUTIONS FOR STRONG LIGHT EXPOSURE	25
9-5	STORAGE	25
9-6	HANDLING PRECAUTIONS FOR PROTECTION FILM	25

Product Specification

1. General Description

The WE550EQE is a Color Active Matrix Liquid Crystal Display with an integral Light Emitting Diode (LED) backlight system. The matrix employs a-Si Thin Film Transistor as the active element. It is a transmissive display type which is operating in the normally black mode. It has a 54.64 inch diagonally measured active display area with QWUXGA resolution (2160 vertical by 3840 horizontal pixel array). Each pixel is divided into Red, Green and Blue sub-pixels or dots which are arrayed in vertical stripes. Gray scale or the luminance of the sub-pixel color is determined with a 10-bit gray scale signal for each dot. Therefore, it can present a palette of more than 1.07Billion colors.

It has been designed to apply the 10-bit 8 Lane V by One interface.

It is intended to support LCD TV, PCTV where high brightness, super wide viewing angle, high color gamut, high color depth and fast response time are important.

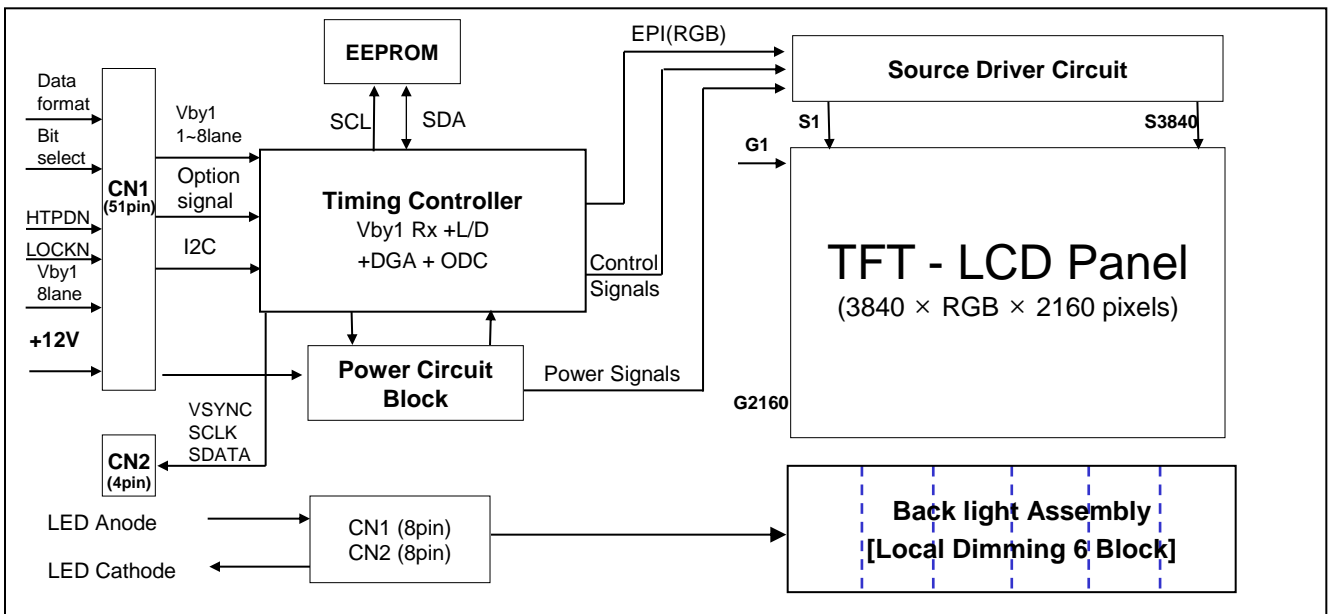

General Features

Active Screen Size	54.64 inches(1387.8mm) diagonal
Outline Dimension	1233.4(H) x 704.7(V) x 14.1(B) / 17.1(D) mm (Typ.)
Pixel Pitch	0.315 mm x 0.315 mm
Pixel Format	3840 horiz. by 2160 vert. Pixels, RGB stripe arrangement
Color Depth	10bit(D), 1.07Billion colors
Luminance, White	350cd/m ² (Center 1point ,Typ.)
Viewing Angle (CR>10)	Viewing angle free (R/L 178 (Min.), U/D 178 (Min.))
Power Consumption	Total 86.79W (Typ.) [Logic= 6.96W (Typ), 9.05(Max), LED Backlight= 79.83W(Typ.) 85.02(Max)]
Weight	12.8kg(Typ.) 13.5kg(Max)
Display Mode	Transmissive mode, Normally black
Surface Treatment	Hard coating(3H), Anti-glare treatment of the front polarizer (Haze 1% Typ.)

2. Absolute Maximum Ratings

The following items are maximum values which, if exceeded, may cause faulty operation or permanent damage to the LCD module.

Table 1. ABSOLUTE MAXIMUM RATINGS

Parameter		Symbol	Value		Unit	Notes
			Min	Max		
Power Input Voltage	LCD Circuit	V _{LCD}	-0.3	+14.0	V _{DC}	1
LED Input Voltage	Forward Voltage	V _F	-	88.7	V _{DC}	
T-Con Option Selection Voltage		V _{LOGIC}	-0.3	+4.0	V _{DC}	
Operating Temperature		T _{OP}	0	+50	°C	2,3
Storage Temperature (without packing)		T _{ST}	-20	+60	°C	
Panel Front Temperature		T _{SUR}	-	+68	°C	4
Operating Ambient Humidity		H _{OP}	10	90	%RH	2,3
Storage Humidity		H _{ST}	5	90	%RH	

- Notes
1. Ambient temperature condition ($T_a = 25 \pm 2 \text{ }^\circ\text{C}$)
 2. Temperature and relative humidity range are shown in the figure below.
Wet bulb temperature should be Max 39°C, and no condensation of water.
 3. Gravity mura can be guaranteed below 40°C condition.
 4. The maximum operating temperatures is based on the test condition that the surface temperature of display area is less than or equal to 68°C with LCD module alone in a temperature controlled chamber. Thermal management should be considered in final product design to prevent the surface temperature of display area from being over 68°C. The range of operating temperature may be degraded in case of improper thermal management in final product design.

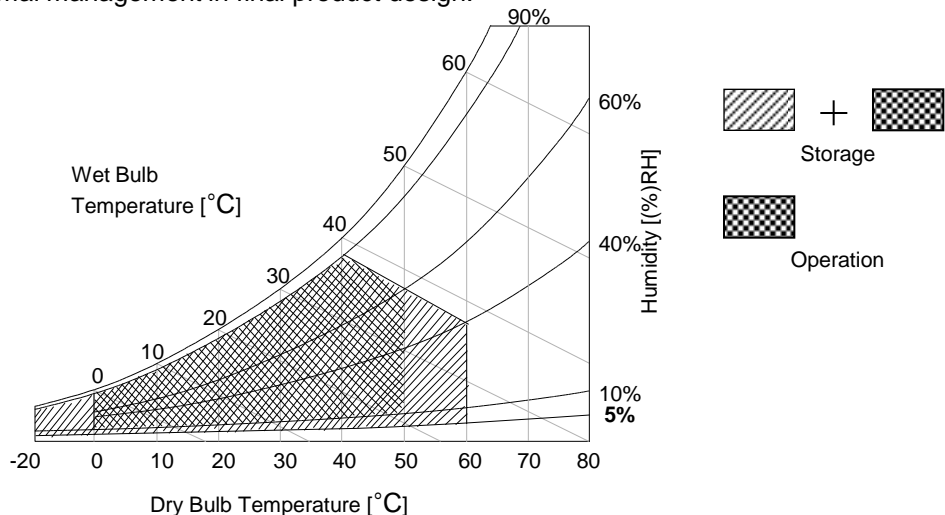

3. Electrical Specifications

3-1. Electrical Characteristics

It requires two power inputs. One is employed to power for the LCD circuit. The other is used for the LED backlight.

Table 2. ELECTRICAL CHARACTERISTICS

Parameter		Symbol	Value			Unit	Note
			Min	Typ	Max		
Circuit :							
Power Input Voltage		V _{LCD}	10.8	12.0	13.2	V _{DC}	
Power Input Current		I _{LCD}	-	580	754	mA	1
			-	1580	2054	mA	2
T-CON Option Selection Voltage	Input High Voltage	V _{IH}	2.7	-	3.6	V _{DC}	
	Input Low Voltage	V _{IL}	0	-	0.7	V _{DC}	
Power Consumption		P _{LCD}	-	6.96	9.05	Watt	1
Rush current		I _{RUSH}	-	-	10	A	3

- Notes
1. The specified current and power consumption are under the V_{LCD}=12.0V, Ta=25 ± 2°C, f_v=60Hz condition, and mosaic pattern(8 x 6) is displayed and f_v is the frame frequency.
 2. The current is specified at the maximum current pattern.
 3. The duration of rush current is about 2ms and rising time of power input is 0.5ms (min.).
 4. Ripple voltage level is recommended under ±5% of typical voltage

White : 1023 Gray
Black : 0 Gray

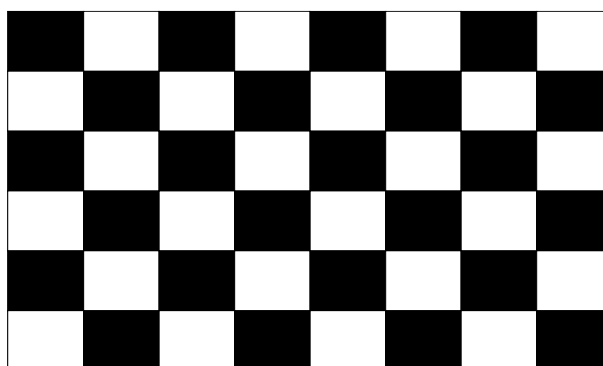

Mosaic Pattern(8 x 6)

Table 3. ELECTRICAL CHARACTERISTICS (Continue)

Parameter	Symbol	Values			Unit	Note	
		Min	Typ	Max			
Backlight Assembly :							
Forward Current (one array)	Anode	$I_{F (anode)}$		540		mAdc	±5%
	Cathode	$I_{F (cathode)}$		180		mAdc	2, 3
Forward Voltage		V_F	69.12	73.92	78.72	Vdc	4
Forward Voltage Variation		ΔV_F			1.7	Vdc	5
Power Consumption		P_{BL}	-	79.83	85.02	W	6
Burst Dimming Duty		On duty	1		100	%	
Burst Dimming Frequency		1/T	95		182	Hz	8
LED Array : (APPENDIX-V)							
Life Time			30,000	50,000		Hrs	7

- Notes :The design of the LED driver must have specifications for the LED array in LCD Assembly. The electrical characteristics of LED driver are based on Constant Current driving type. The performance of the LED in LCM, for example life time or brightness, is extremely influenced by the characteristics of the LED Driver. So, all the parameters of an LED driver should be carefully designed. When you design or order the LED driver, please make sure unwanted lighting caused by the mismatch of the LED and the driver (no lighting, flicker, etc) has never been occurred. When you confirm it, the LCD-Assembly should be operated in the same condition as installed in your instrument.
1. Electrical characteristics are based on LED Array specification.
 2. Specified values are defined for a Backlight Assembly. (IBL :2 LED array/LCM)
 3. Each LED array has one anode terminal and three cathode terminals.
The forward current(I_F) of the anode terminal is 540mA and it supplies 180mA into three strings, respectively

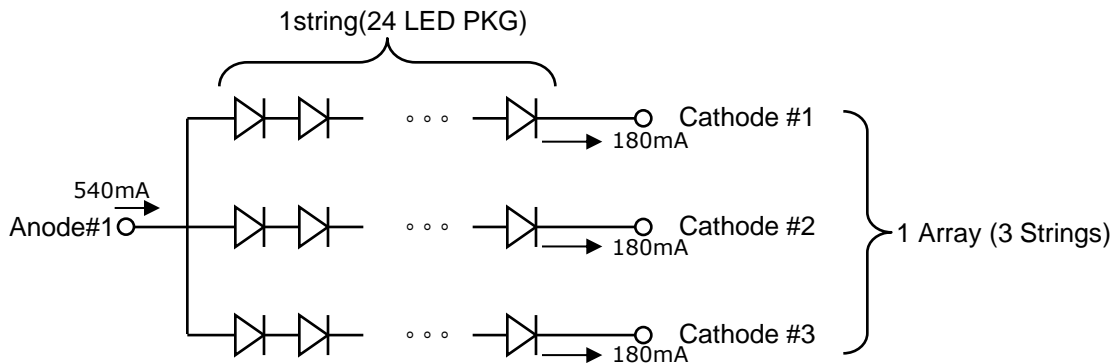

4. The forward voltage(V_F) of LED array depends on ambient temperature (Appendix-V)
5. ΔV_F means Max V_F -Min V_F in one Backlight. So V_F variation in a Backlight isn't over Max. 1.7V
6. Maximum level of power consumption is measured at initial turn on.
Typical level of power consumption is measured after 1hrs aging at $25 \pm 2^\circ C$.
7. The life time(MTTF) is determined as the time at which brightness of the LED is 50% compared to that of initial value at the typical LED current on condition of continuous operating at $25 \pm 2^\circ C$, based on duty 100%.
8. The reference method of burst dimming duty ratio.
It is recommended to use synchronous V-sync frequency to prevent waterfall
($V_{sync} * 2 = \text{Burst Frequency}$)

Product Specification

3-2. Interface Connections

This LCD module employs three kinds of interface connection, 51-pin connector is used for the module electronics and 8-pin, 8-pin connectors are used for the integral backlight system.

3-2-1. LCD Module

- LCD Connector(CN1): FI-RXE51S-HF (manufactured by JAE)
- GT05S-51S-H38 (manufactured by LSM)
- IS050-C51B-C39-C (manufactured by UJU)

Table 4. MODULE CONNECTOR(CN1) PIN CONFIGURATION

No	Symbol	Description	No	Symbol	Description
1	VLCD	Power Supply +12.0V	27	GND	Ground
2	VLCD	Power Supply +12.0V	28	Rx0n	V-by-One HS Data Lane 0
3	VLCD	Power Supply +12.0V	29	Rx0p	V-by-One HS Data Lane 0
4	VLCD	Power Supply +12.0V	30	GND	Ground
5	VLCD	Power Supply +12.0V	31	Rx1n	V-by-One HS Data Lane 1
6	VLCD	Power Supply +12.0V	32	Rx1p	V-by-One HS Data Lane 1
7	VLCD	Power Supply +12.0V	33	GND	Ground
8	VLCD	Power Supply +12.0V	34	Rx2n	V-by-One HS Data Lane 2
9	NC	NO CONNECTION	35	Rx2p	V-by-One HS Data Lane 2
10	GND	Ground	36	GND	Ground
11	GND	Ground	37	Rx3n	V-by-One HS Data Lane 3
12	GND	Ground	38	Rx3p	V-by-One HS Data Lane 3
13	GND	Ground	39	GND	Ground
14	NC	NO CONNECTION (Note 3)	40	Rx4n	V-by-One HS Data Lane 4
15	NC	NO CONNECTION (Note 3)	41	Rx4p	V-by-One HS Data Lane 4
16	NC	NO CONNECTION (Note 3)	42	GND	Ground
17	NC	NO CONNECTION (Note 3)	43	Rx5n	V-by-One HS Data Lane 5
18	SDA	SDA (For Local Dimming)	44	Rx5p	V-by-One HS Data Lane 5
19	SCL	SCL (For Local Dimming)	45	GND	Ground
20	NC	NO CONNECTION (Note 3)	46	Rx6n	V-by-One HS Data Lane 6
21	Bit SEL	H or NC= 10bit(D), L = 8bit	47	Rx6p	V-by-One HS Data Lane 6
22	Local Dimming	H : On, L or NC Off	48	GND	Ground
23	AGP or NSB	'H' or NC : AGP 'L' : NSB (No signal Black)	49	Rx7n	V-by-One HS Data Lane 7
24	GND	Ground	50	Rx7p	V-by-One HS Data Lane 7
25	HTPDN	Hot plug detect	51	GND	Ground
26	LOCKN	Lock detect	-	-	-

- Note
1. All GND (ground) pins should be connected together to the LCD module's metal frame.
 2. All Input levels of V-by-One signals are based on the V-by-One-HS Standard Version 1.4
 3. #14~#17, #20 NC(No Connection) : These pins are used only for LGD (Do not connect)
 4. Specific pin (#22) is used for Local Dimming function of the LCD module.
If not used, these pins are no connection. (Please see the Appendix IV-1, V for more information.)
 5. Specific pin No. #23 is used for "No signal detection" of system signal interface.
It should be GND for NSB (No Signal Black) while the system interface signal is not.
If this pin is "H", LCD Module displays AGP (Auto Generation Pattern).
 6. Specific pin (pin No. #18, #19) is used for Controlling Local Dimming register in the LCM Module.

Product Specification

3-2-2. Backlight Module

Master

-LED Driver Connector

: 2002WR - H14B2(Yeonho) or Compatible

- Mating Connector

: 2002HS - 14B2 (Yeonho) or Compatible

Table 5-1. LED DRIVER CONNECTOR PIN CONFIGURATION

Pin No	Symbol	Description	Note
1	VBL	Power Supply +24.0V	
2	VBL	Power Supply +24.0V	
3	VBL	Power Supply +24.0V	
4	VBL	Power Supply +24.0V	
5	VBL	Power Supply +24.0V	
6	GND	Backlight Ground	1
7	GND	Backlight Ground	
8	GND	Backlight Ground	
9	GND	Backlight Ground	
10	GND	Backlight Ground	
11	Status	Back Light Status	2
12	VON/OFF	Backlight ON/OFF control	3
13	NC	Don't care	
14	Adj	Adjustable light	

Notes :1. GND should be connected to the LCD module's metal frame.

2. Normal : Low (under 0.7V) / Abnormal : Open

3. Each impedance of pin #12 is over 50 [KΩ] .

◆ Rear view of LCM

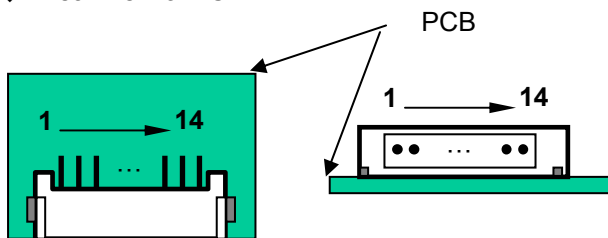

<Master>

◆ Status

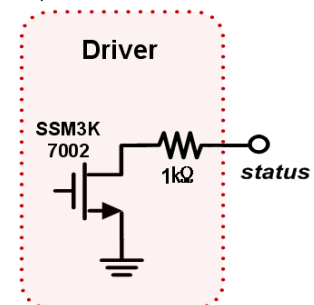

Product Specification

3-3. Signal Timing Specifications

Table 6 shows the signal timing required at the input of the Vx1 transmitter. All of the interface signal timings should be satisfied with the following specification for normal operation.

Table 6. TIMING TABLE (DE Only Mode)

ITEM		Symbol	Min	Typ	Max	Unit	Note
Horizontal	Display Period	t_{HV}	480	480	480	t_{CLK}	3840/8
	Blank	t_{HB}	60	70	120	t_{CLK}	1
	Total	t_{HP}	540	550	600	t_{CLK}	
Vertical	Display Period	t_{VV}	2160	2160	2160	Lines	
	Blank	t_{VB}	40	90	600	Lines	1
	Total	t_{VP}	2200	2250	2760	Lines	

ITEM		Symbol	Min	Typ	Max	Unit	Note
Frequency	DCLK	f_{CLK}	60	74.25	78.00	MHz	
	Horizontal	f_H	121.8	135	140	KHz	2
	Vertical	f_V	47	60	63	Hz	2

notes: 1. The input of HSYNC & VSYNC signal does not have an effect on normal operation (DE Only Mode).
If you use spread spectrum of EMI, add some additional clock to minimum value for clock margin.

2. The performance of the electro-optical characteristics may be influenced by variance of the vertical refresh rate and the horizontal frequency

3. Spread Spectrum Rate (SSR) is limited to $\pm 0.5\%$ center spread at 30KHz

※ Timing should be set based on clock frequency.

3-4. V by One input signal Characteristics

3-4-1. V by One Input Signal Timing Diagram

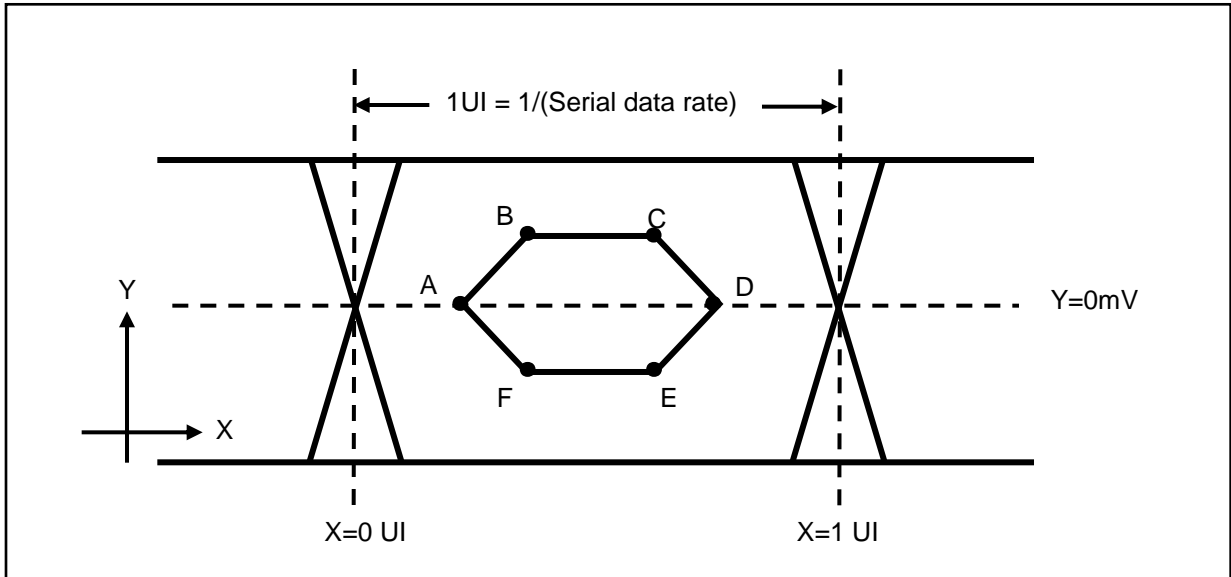
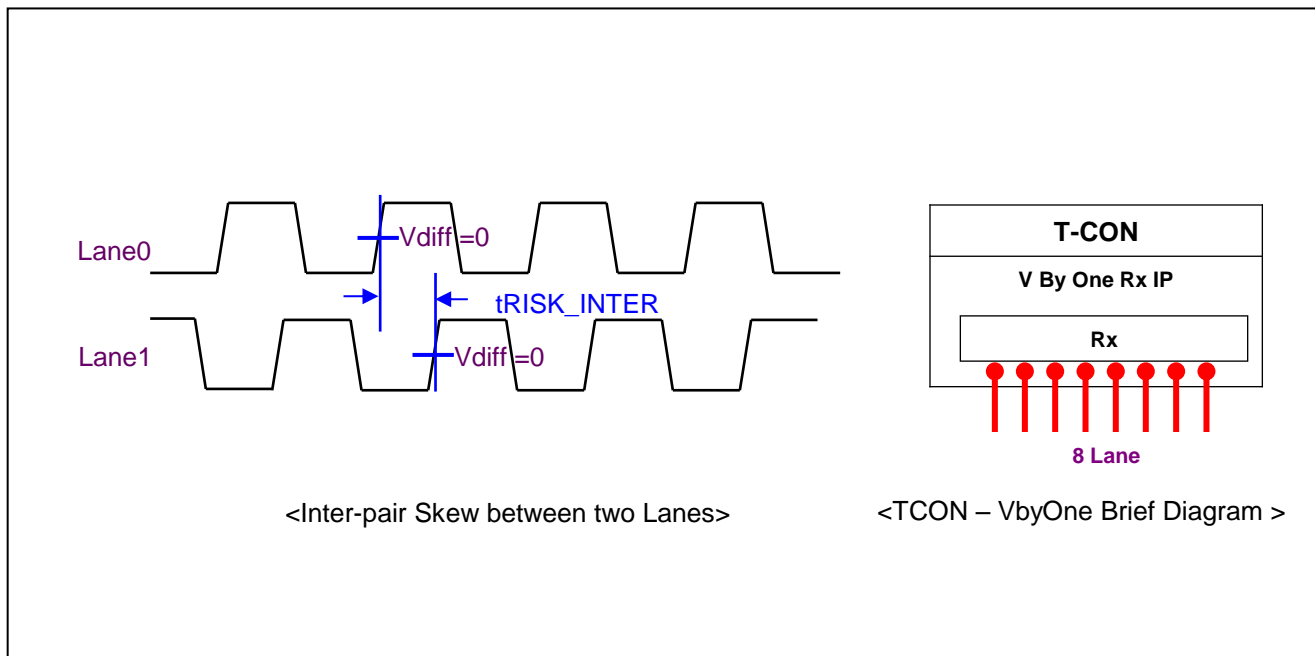

Table7. Eye Mask Specification

	X[UI]	Note	Y[mV]	Note
A	0.25 (max)	2	0	-
B	0.3 (max)	2	50	3
C	0.7(min)	3	50	3
D	0.75(min)	3	0	-
E	0.7(min)	3	-50	3
F	0.3(max)	2	-50	3

- notes
1. All Input levels of V by One signals are based on the V by One HS Standard Ver. 1.4
 2. This is allowable maximum value.
 3. This is allowable minimum value.
 4. The eye diagram is measured by the oscilloscope and receiver CDR characteristic must be emulated.
 - PLL bandwidth : 15 Mhz
 - Damping Factor : 1.5

3-4-2. V by One Input Signal Characteristics



Description	Symbol	Min	Max	Unit	notes
Allowable inter-pair skew between lanes	t_{RISK_INTER}	-	5	UI	1,2

Notes 1.1UI = 1/serial data rate

2. it is the time difference of the differential voltage between any two lanes in one sub block.

3-5. Color Data Reference

The brightness of each primary color (red, green, blue) is based on the 10bit or 8bit gray scale data input for the color. The higher the binary input, the brighter the color. Table 8 provides a reference for color versus data input.

Table 8. COLOR DATA REFERENCE

Packer input & Unpacker output		30bpp RGB (10bit)	24bpp RGB (8bit)
Byte0	D[0]	R[2]	R[0]
	D[1]	R[3]	R[1]
	D[2]	R[4]	R[2]
	D[3]	R[5]	R[3]
	D[4]	R[6]	R[4]
	D[5]	R[7]	R[5]
	D[6]	R[8]	R[6]
	D[7]	R[9]	R[7]
Byte1	D[8]	G[2]	G[0]
	D[9]	G[3]	G[1]
	D[10]	G[4]	G[2]
	D[11]	G[5]	G[3]
	D[12]	G[6]	G[4]
	D[13]	G[7]	G[5]
	D[14]	G[8]	G[6]
	D[15]	G[9]	G[7]
Byte2	D[16]	B[2]	B[0]
	D[17]	B[3]	B[1]
	D[18]	B[4]	B[2]
	D[19]	B[5]	B[3]
	D[20]	B[6]	B[4]
	D[21]	B[7]	B[5]
	D[22]	B[8]	B[6]
	D[23]	B[9]	B[7]
Byte3	D[24]	Don't care	
	D[25]	Don't care	
	D[26]	B[0]	
	D[27]	B[1]	
	D[28]	G[0]	
	D[29]	G[1]	
	D[30]	R[0]	
	D[31]	R[1]	

3-6. Power Sequence

3-6-1. LCD Driving circuit

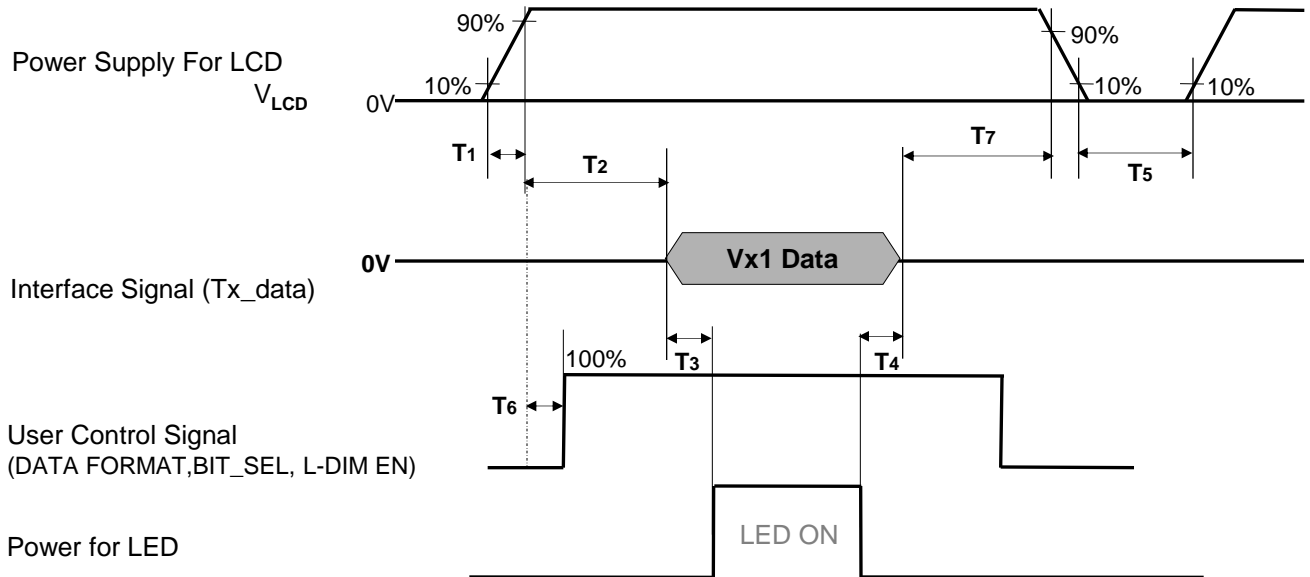

Table 9. POWER SEQUENCE

Parameter	Value			Unit	Notes
	Min	Typ	Max		
T1	0.5	-	20	ms	1
T2	0	-	-	ms	2
T3	400	-	-	ms	3
T4	100	-	-	ms	3
T5	1.0	-	-	s	4
T6	0	-	T2	ms	5
T7	0	-	-	ms	6

- Note :
1. Even though T1 is over the specified value, there is no problem if I2T spec of fuse is satisfied.
 2. If T2 is satisfied with specification after removing V by One Cable, there is no problem.
 3. The T3 / T4 is recommended value, the case when failed to meet a minimum specification, abnormal display would be shown. There is no reliability problem.
 4. T5 should be measured after the Module has been fully discharged between power off and on period.
 5. If the on time of signals (Interface signal and user control signals) precedes the on time of Power (V_{LCD}), it will be happened abnormal display. When T6 is NC status, T6 doesn't need to be measured.
 6. It is recommendation specification that T7 has to be 0ms as a minimum value.
 - ※ Please avoid floating state of interface signal at invalid period.
 - ※ When the power supply for LCD (VLCD) is off, be sure to pull down the valid and invalid data to 0V.

Product Specification

4. Optical Specification

Optical characteristics are determined after the unit has been 'ON' and stable in a dark environment at $25 \pm 2^\circ\text{C}$. The values are specified at distance 50cm from the LCD surface at a viewing angle of Φ and θ equal to 0° . FIG. 1 shows additional information concerning the measurement equipment and method.

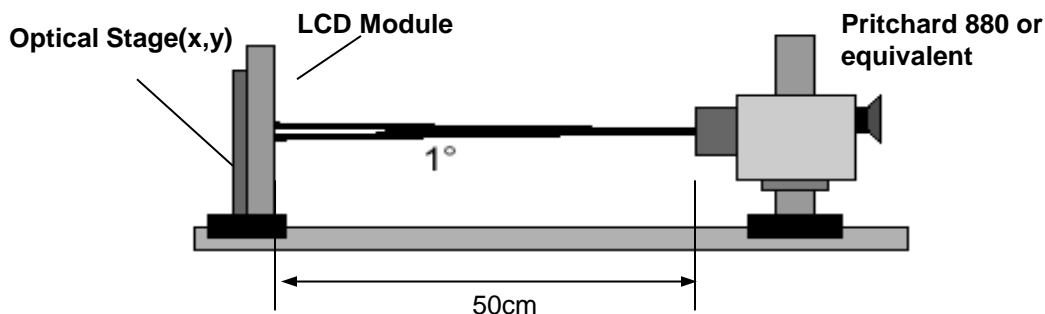

FIG. 1 Optical Characteristic Measurement Equipment and Method

$T_a = 25 \pm 2^\circ\text{C}$, $V_{\text{LCD}} = 12.0\text{V}$, $f_v = 60\text{Hz}$, $D_{\text{clk}} = 74.25\text{MHz}$
EXTVbr-B=100%

Table 11. OPTICAL CHARACTERISTICS

Parameter		Symbol		Value			Unit	notes	
				Min	Typ	Max			
Contrast Ratio		CR		800	1300	-		1	
Surface Luminance, white		L_{WH}	2D	320	350	-	cd/m ²	2	
Luminance Variation		δ_{WHITE}	9P	65	-	-		3	
Response Time	Gray to Gray	G to G			8	12	ms	4	
Color Coordinates [CIE1931]	RED	Rx		Typ -0.03	0.648	Typ +0.03			
		Ry			0.333				
	GREEN	Gx			0.308				
		Gy			0.604				
	BLUE	Bx			0.153				
		By			0.054				
	WHITE	Wx			0.281				
		Wy			0.288				
Color Temperature					10,000		K		
Color Gamut					72		%		
Viewing Angle	2D (CR>10)	right($\phi=0^\circ$)		θ_r (x axis)	89	-	-	degree	6
		left ($\phi=180^\circ$)		θ_l (x axis)	89	-	-		
		up ($\phi=90^\circ$)		θ_u (y axis)	89	-	-		
		down ($\phi=270^\circ$)		θ_d (y axis)	89	-	-		
Gray Scale					-	-	-		7

Product Specification

notes :1. Contrast Ratio(CR) is defined mathematically as :

$$\text{Contrast Ratio} = \frac{\text{Surface Luminance with all white pixels}}{\text{Surface Luminance with all black pixels}}$$

It is measured at center 1-point.

2. Surface luminance is determined after the unit has been 'ON' and 1 Hour after lighting the backlight in a dark environment at $25 \pm 2^\circ\text{C}$. Surface luminance is the luminance value at center 1-point across the LCD surface 50cm from the surface with all pixels displaying white.

For more information see the FIG. 1.

3. The variation in surface luminance, δ WHITE is defined as :

$$\delta \text{ WHITE}(9P) = \text{Minimum}(L_{on1}, L_{on2} \sim L_{on8}, L_{on9}) / \text{Maximum}(L_{on1}, L_{on2} \sim L_{on8}, L_{on9}) * 100$$

Where L_{on1} to L_{on9} are the luminance with all pixels displaying white at 9 locations.

For more information, see the FIG. 2.

4. Response time is the time required for the display to transit from G(N) to G(M) (Rise Time, TrR) and from G(M) to G(N) (Decay Time, TrD). For additional information see the FIG. 3. (N<M)

※ G to G Spec stands for average value of all measured points.

Photo Detector : RD-80S / Field : 2°

5. G to G σ is Variation of Gray to Gray response time composing a picture

$$G \text{ to } G (\sigma) = \sqrt{\frac{\sum(Xi - u)^2}{N}}$$

Xi = Individual Data
u = Data average
N : The number of Data

6. Viewing angle is the angle at which the contrast ratio is greater than 10. The angles are determined for the horizontal or x axis and the vertical or y axis with respect to the z axis which is normal to the LCD module surface. For more information, see the FIG. 4.

7. Gray scale specification

Gamma Value is approximately 2.2. For more information, see the Table 12

Table 12. GRAY SCALE SPECIFICATION

Gray Level	Luminance [%] (Typ)
L0	0.083
L63	0.27
L127	1.04
L191	2.49
L255	4.68
L319	7.66
L383	11.5
L447	16.1
L511	21.6
L575	28.1
L639	35.4
L703	43.7
L767	53.0
L831	63.2
L895	74.5
L959	86.7
L1023	100

Measuring point for surface luminance & measuring point for luminance variation.

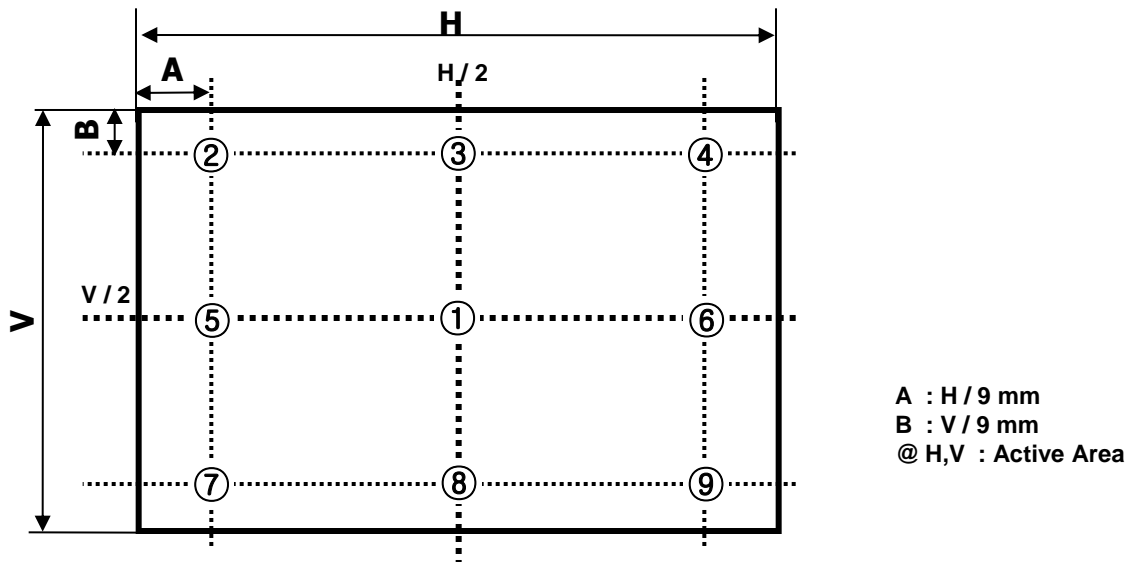

FIG. 2 9 Points for Luminance Measure

Response time is defined as the following figure and shall be measured by switching the input signal for “Gray(N)” and “Gray(M)”.

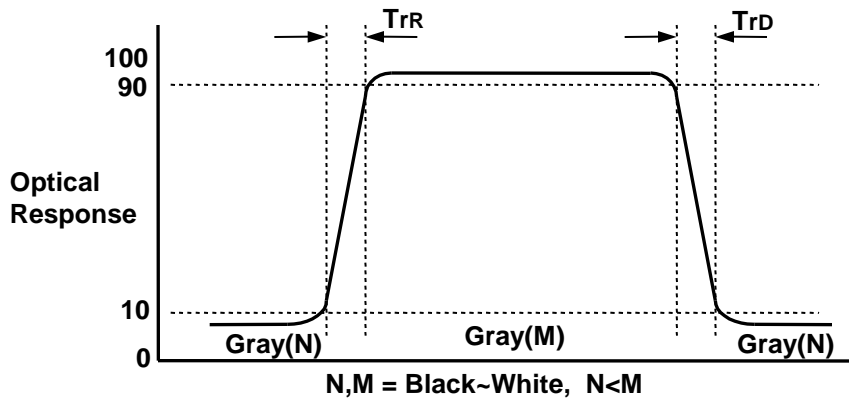

FIG. 3 Response Time

Dimension of viewing angle range

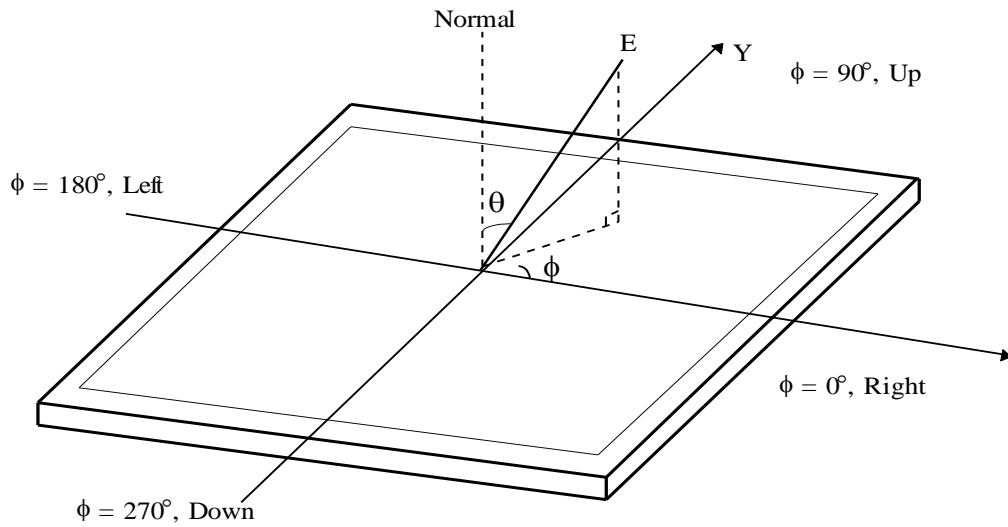

FIG. 4 Viewing Angle

5. Mechanical Characteristics

Table 13 provides general mechanical characteristics.

Table 13. MECHANICAL CHARACTERISTICS

Item	Value	
Outline Dimension	Horizontal	1233.4 mm
	Vertical	704.7mm
	Depth	14.1mm
Bezel Area	Horizontal	1215.6mm
	Vertical	686.7mm
Active Display Area	Horizontal	1209.6 mm
	Vertical	680.4 mm
Case Top	Material	Up/Down : CR Side : PC+ABS (G/F 15%)
	Case Top Color	Up/Down : Carbon Titan Side : Black
	LG Logo Color	Silver (LGE Pantone Color : 877C)
	Ultra HD Logo Color	Silver (LGE Pantone Color : 877C)
Weight	12.8kg(Typ.) 13.5kg(Max)	

notes : Please refer to a mechanical drawing in terms of tolerance at the next page.

[FRONT VIEW]



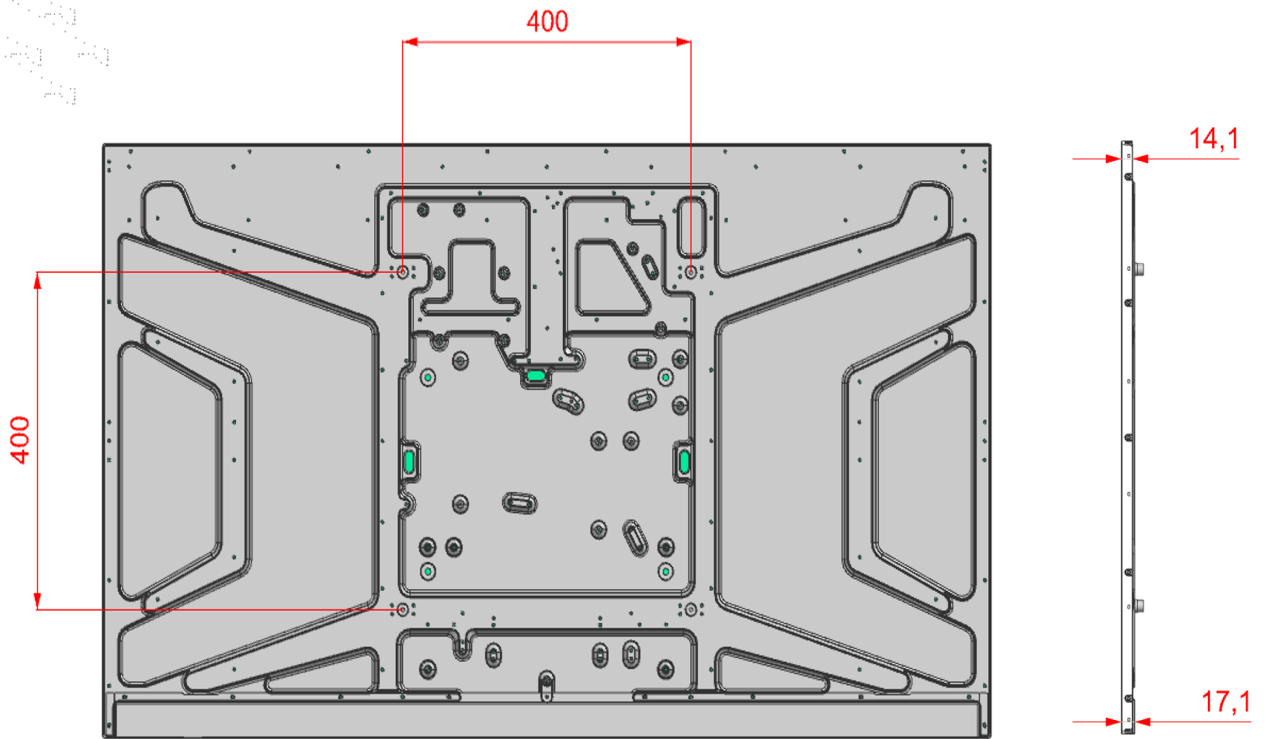

Welcome to request 3D structure drawing by winmax

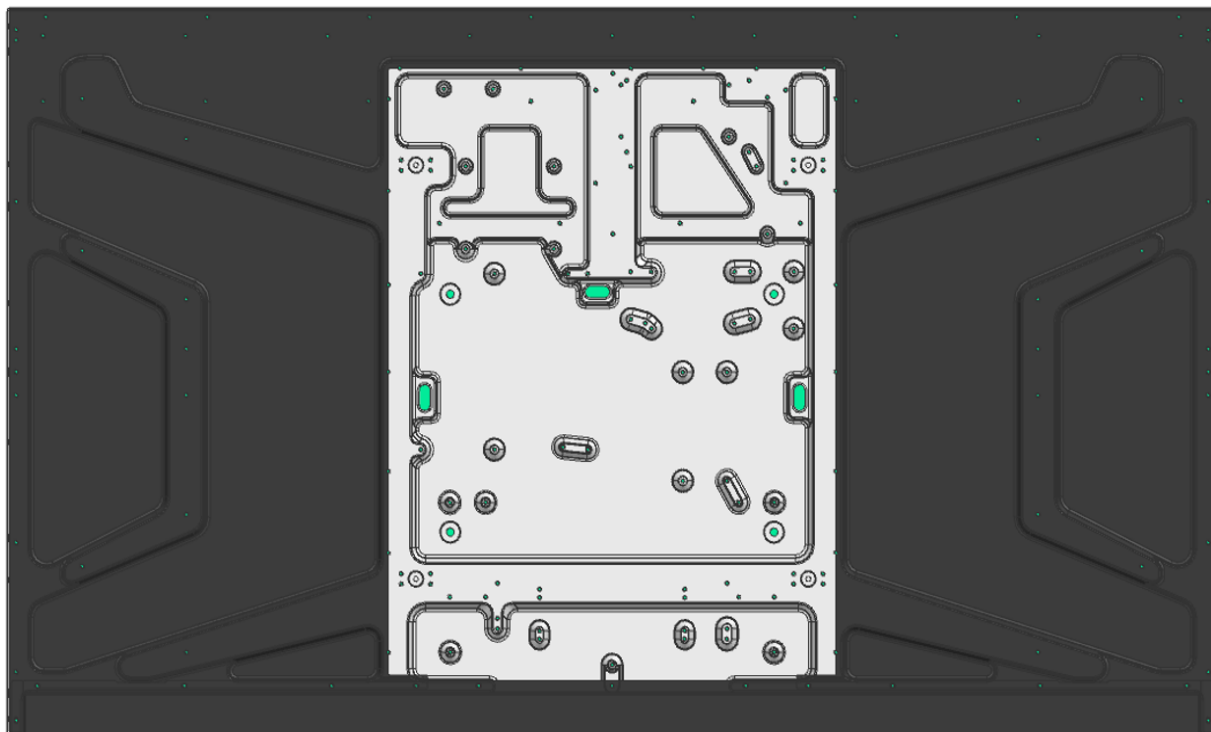

背面

Product Specification

6. Reliability

Table 14. ENVIRONMENT TEST CONDITION

No.	Test Item	Condition
1	High temperature storage test	Ta= 60°C 90% 240h
2	Low temperature storage test	Ta= -20°C 240h
3	High temperature operation test	Ta= 50°C 50%RH 500h
4	Low temperature operation test	Ta= 0°C 500h
5	Humidity condition Operation	Ta= 40 °C, 90%RH
6	Altitude operating storage / shipment	0 – 16,400 ft 0 - 40,000 ft
7	Vibration test (non-operating)	Wave form : Random Vibration Level 1.0Grms Bandwidth : 10 ~ 300Hz Duration : X, Y, Z Each direction Per 10min
8	Shock test (non-operating)	Shock level : 20Grms Waveform : half sine wave, 11ms Direction : X, Y, Z One time each direction * Specification will be finalized by 2015/2/28
9	Panel Push Test (Module Condition)	Max 6KgF

- notes : 1. Before and after Reliability test, LCM should be operated with normal function.
2. These conditions are for LGD's internal test. Please refer to Absolute Maximum Ratings (Table1) for guaranteed condition.

7. International Standards

7-1. Safety

- a) UL 60065, Underwriters Laboratories Inc.
Audio, Video and Similar Electronic Apparatus - Safety Requirements.
- b) CAN/CSA-C22.2 No. 60065-03, Canadian Standards Association.
Audio, Video and Similar Electronic Apparatus - Safety Requirements.
- c) EN 60065, European Committee for Electrotechnical Standardization (CENELEC).
Audio, Video and Similar Electronic Apparatus - Safety Requirements.
- d) IEC 60065, The International Electrotechnical Commission (IEC).
Audio, Video and Similar Electronic Apparatus - Safety Requirements.

7-2. EMC

- a) ANSI C63.4 "American National Standard for Methods of Measurement of Radio-Noise Emissions from Low-Voltage Electrical and Electronic Equipment in the Range of 9 kHz to 40 GHz." American National Standards Institute (ANSI), 2003.
- b) CISPR 22 "Information technology equipment – Radio disturbance characteristics – Limit and methods of measurement." International Special Committee on Radio Interference (CISPR), 2005.
- c) CISPR 13 "Sound and television broadcast receivers and associated equipment – Radio disturbance characteristics – Limits and method of measurement." International Special Committee on Radio Interference (CISPR), 2006.

7-3. Environment

- a) RoHS, Directive 2011/65/EU of the European Parliament and of the council of 8 June 2011

Product Specification

8. Packing

8-1. Information of LCM Label

a) Lot Mark

A	B	C	D	E	F	G	H	I	J	K	L	M
---	---	---	---	---	---	---	---	---	---	---	---	---

A,B,C : SIZE(INCH)
E : MONTH

D : YEAR
F ~ M : SERIAL NO.

notes

1. YEAR

Year	2011	2012	2013	2014	2015	2016	2017	2018	2019	2020
Mark	A	B	C	D	E	F	G	H	J	K

2. MONTH

Month	Jan	Feb	Mar	Apr	May	Jun	Jul	Aug	Sep	Oct	Nov	Dec
Mark	1	2	3	4	5	6	7	8	9	A	B	C

b) Location of Lot Mark

Serial NO. is printed on the label. The label is attached to the backside of the LCD module.
This is subject to change without prior notice.

8-2. Packing Form

a) Package quantity in one Pallet : 20 pcs

b) Pallet Size : 1440 mm(W) X 1140 mm(D) X 950 mm(H)

9. Precautions

Please pay attention to the followings when you use this TFT LCD module.

9-1. Mounting Precautions

- (1) You must mount a module using specified mounting holes (Details refer to the drawings).
- (2) You should consider the mounting structure so that uneven force (ex. Twisted stress, Concentrated stress) is not applied to the module. And the case on which a module is mounted should have sufficient strength so that external force is not transmitted directly to the module.
- (3) Please attach the surface transparent protective plate to the surface in order to protect the polarizer. Transparent protective plate should have sufficient strength in order to resist external force.
- (4) You should adopt radiation structure to satisfy the temperature specification.
- (5) Acetic acid type and chlorine type materials for the cover case are not desirable because the former generates corrosive gas of attacking the polarizer at high temperature and the latter causes circuit break by electro-chemical reaction.
- (6) Do not touch, push or rub the exposed polarizers with glass, tweezers or anything harder than HB pencil lead. And please do not rub with dust clothes with chemical treatment. Do not touch the surface of polarizer for bare hand or greasy cloth. (Some cosmetics are detrimental to the polarizer.)
- (7) When the surface becomes dusty, please wipe gently with absorbent cotton or other soft materials like chamois soaks with petroleum benzine. Normal-hexane is recommended for cleaning the adhesives used to attach front / rear polarizers. Do not use acetone, toluene and alcohol because they cause chemical damage to the polarizer
- (8) Wipe off saliva or water drops as soon as possible. Their long time contact with polarizer causes deformations and color fading.
- (9) Do not open the case because inside circuits do not have sufficient strength.

9-2. Operating Precautions

- (1) Response time depends on the temperature. (In lower temperature, it becomes longer.)
- (2) Brightness depends on the temperature. (In lower temperature, it becomes lower.)
And in lower temperature, response time (required time that brightness is stable after turned on) becomes longer
- (3) Be careful for condensation at sudden temperature change. Condensation makes damage to polarizer or electrical contacted parts. And after fading condensation, smear or spot will occur.
- (4) When fixed patterns are displayed for a long time, remnant image is likely to occur.
- (5) Module has high frequency circuits. Sufficient suppression to the electromagnetic interference shall be done by system manufacturers. Grounding and shielding methods may be important to minimize the interference.
- (6) Please do not give any mechanical and/or acoustical impact to LCM. Otherwise, LCM can't be operated its full characteristics perfectly.
- (7) A screw which is fastened up the steels should be a machine screw.
(if not, it can cause conductive particles and deal LCM a fatal blow)
- (8) Please do not set LCD on its edge.
- (9) The conductive material and signal cables are kept away from LED driver inductor to prevent abnormal display, sound noise and temperature rising.

9-3. Electrostatic Discharge Control

Since a module is composed of electronic circuits, it is not strong to electrostatic discharge. Make certain that treatment persons are connected to ground through wrist band etc. And don't touch interface pin directly.

9-4. Precautions for Strong Light Exposure

Strong light exposure causes degradation of polarizer and color filter.

9-5. Storage

When storing modules as spares for a long time, the following precautions are necessary.

- (1) Store them in a dark place. Do not expose the module to sunlight or fluorescent light. Keep the temperature between 5°C and 35°C at normal humidity.
- (2) The polarizer surface should not come in contact with any other object.
It is recommended that they be stored in the container in which they were shipped.
- (3) Storage condition is guaranteed under packing conditions.
- (4) The phase transition of Liquid Crystal in the condition of the low or high storage temperature will be recovered when the LCD module returns to the normal condition.

9-6. Handling Precautions for Protection Film

- (1) The protection film is attached to the bezel with a small masking tape.
When the protection film is peeled off, static electricity is generated between the film and polarizer.
This should be peeled off slowly and carefully by people who are electrically grounded and with well ion-blown equipment or in such a condition, etc.
- (2) When the module with protection film attached is stored for a long time, sometimes there remains a very small amount of glue still on the bezel after the protection film is peeled off.
- (3) You can remove the glue easily. When the glue remains on the bezel surface or its vestige is recognized, please wipe them off with absorbent cotton waste or other soft material like chamois soaked with normal-hexane.

APPENDIX- I

■ Pallet Ass'y

<PJ/GZ>

The assembly process for the PJ/GZ pallet consists of six steps:

- Step 1: Components 1 and 2 are shown. Component 1 is a dark grey rectangular panel, and component 2 is a similar panel with yellow tape tabs.
- Step 2: Components 3, 4, and 5 are shown. Component 3 is a brown cardboard box, component 4 is a wooden pallet, and component 5 is a layer of packing paper.
- Step 3: Component 6 is shown, which is a side rib of EPS packing material being placed inside the box on the pallet.
- Step 4: Component 7 is shown, which is a top layer of packing paper being placed on top of the box.
- Step 5: The assembled box is shown on the pallet, with components 8 and 9 (steel bands and labels) being added.
- Step 6: The final assembled pallet is shown, with components 8 and 9 clearly visible.

NO.	DESCRIPTION	MATERIAL
①	LCD Module	55INCH
②	AL BAG	AL
③	Tape	OPP
④	PALLET	PLYWOOD
⑤	PACKING,BOTTOM	PAPER
⑥	PACKING,SIDE RIB	EPS
⑦	PACKING, TOP	PAPER
⑧	BAND,CLIP	STEEL,PP
⑨	LABEL	YUPO 80G 100X70

<WR>

The assembly process for the WR pallet consists of six steps:

- Step 1: Components 1 and 2 are shown. Component 1 is a dark grey rectangular panel, and component 2 is a similar panel with yellow tape tabs.
- Step 2: Components 3, 4, and 5 are shown. Component 3 is a grey plastic U-pad, component 4 is a wooden pallet, and component 5 is a layer of EPS packing material.
- Step 3: Component 6 is shown, which is another layer of EPS packing material being placed inside the U-pad on the pallet.
- Step 4: Component 7 is shown, which is a top layer of EPS packing material being placed on top of the U-pad.
- Step 5: The assembled U-pad is shown on the pallet, with components 8 and 9 (steel bands and labels) being added.
- Step 6: The final assembled pallet is shown, with components 8 and 9 clearly visible.

NO.	DESCRIPTION	MATERIAL
①	LCD Module	55INCH
②	PE BAG	PE
③	Tape	OPP
④	PALLET	PLYWOOD
⑤	PACKING,BOTTOM	EPS
⑥	PACKING, U-PAD	EPS
⑦	PACKING, TOP	EPS
⑧	BAND,CLIP	STEEL, PP
⑨	LABEL	YUPO 80G 100X70

Product Specification

APPENDIX- II-1

■ LCM Label



■ Production site

Note 1. The origin of LCM Label will be changed according to the production site.

APPENDIX- II-2

■ Pallet Label



APPENDIX- III

■ Required signal assignment for Flat Link (Thine : THCV215) Transmitter

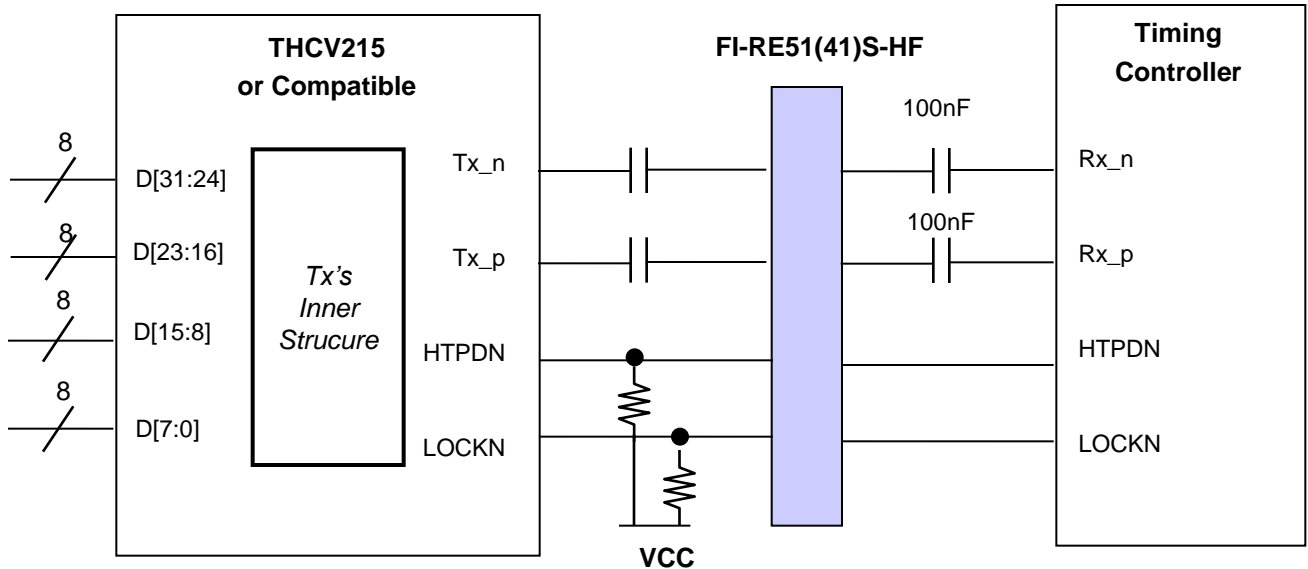
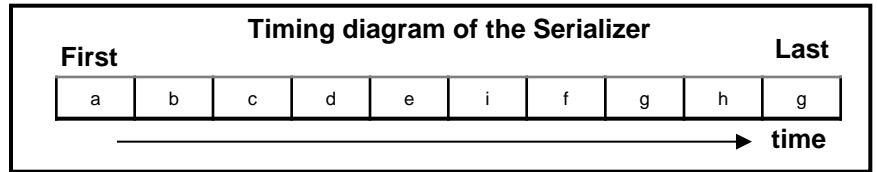
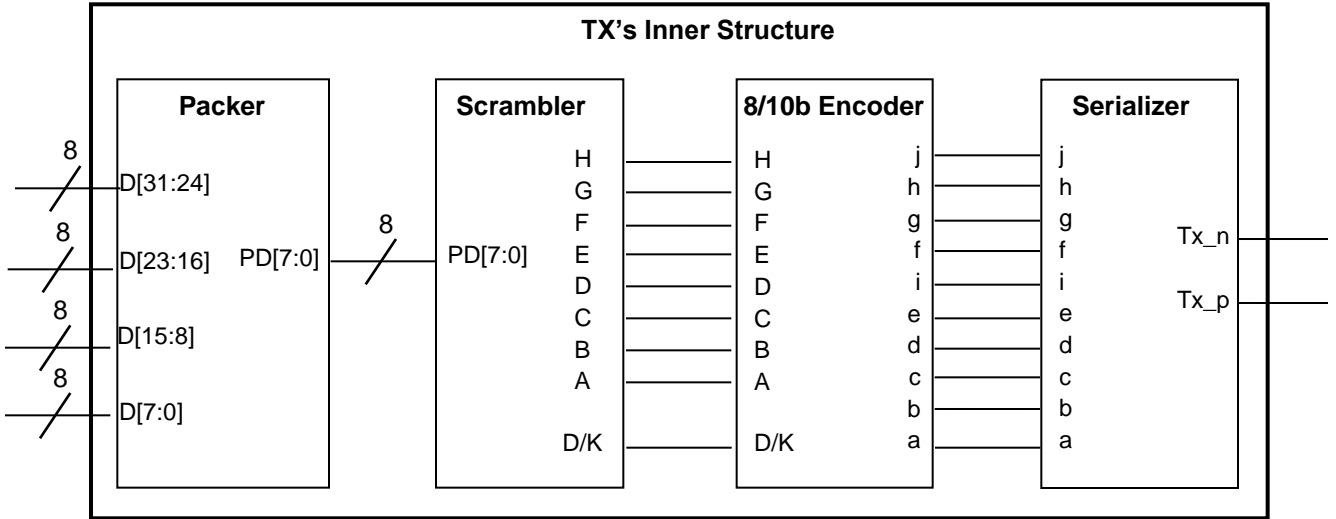

- notes: 1. The LCD module uses a 100 nF capacitor on positive and negative lines of each receiver input.
 2. Refer to Vx1 Transmitter Data Sheet for detail descriptions. (THCV215 or Compatible)
 3. About Module connector pin configuration, Please refer to the Page 7

APPENDIX- IV-1

■ Option Pin Circuit Block Diagram

1) Circuit Block Diagram of Bit Selection pin

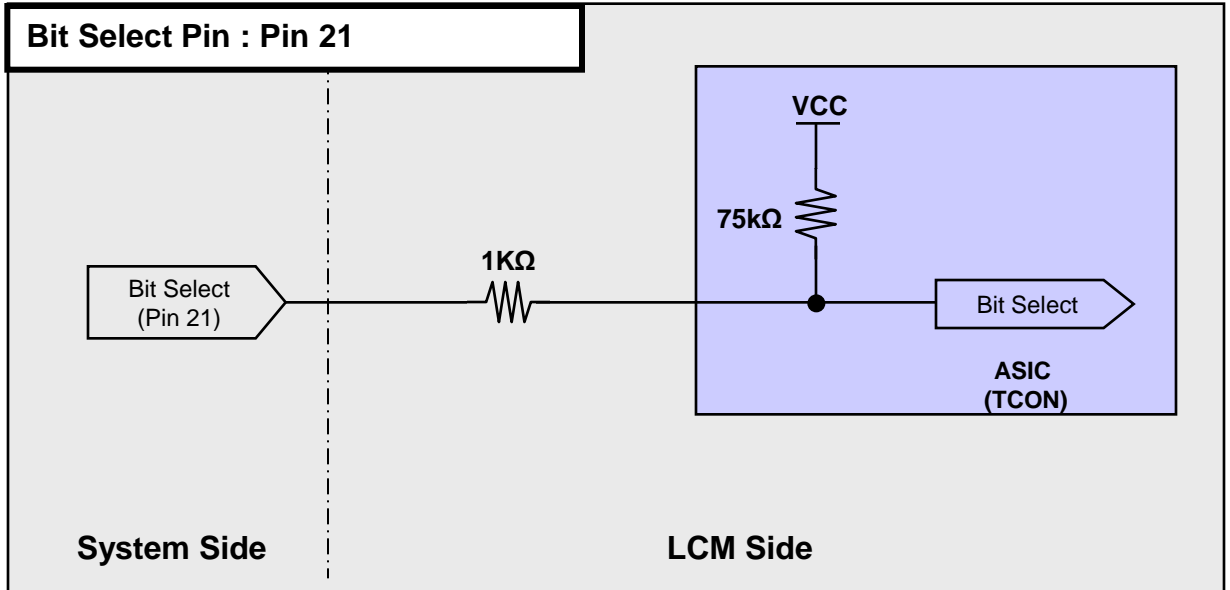

2) Circuit Block Diagram of L-Dim Enable Selection pin

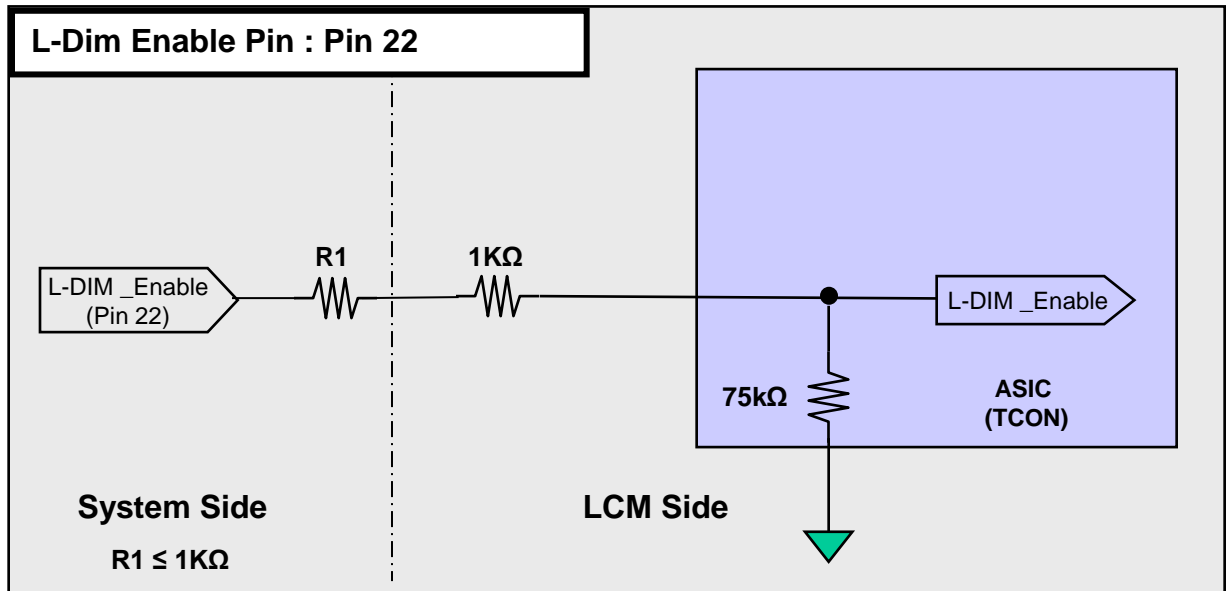

APPENDIX- IV-2

■ Option Pin Circuit Block Diagram

3) Circuit Block Diagram of AGP Selection pin

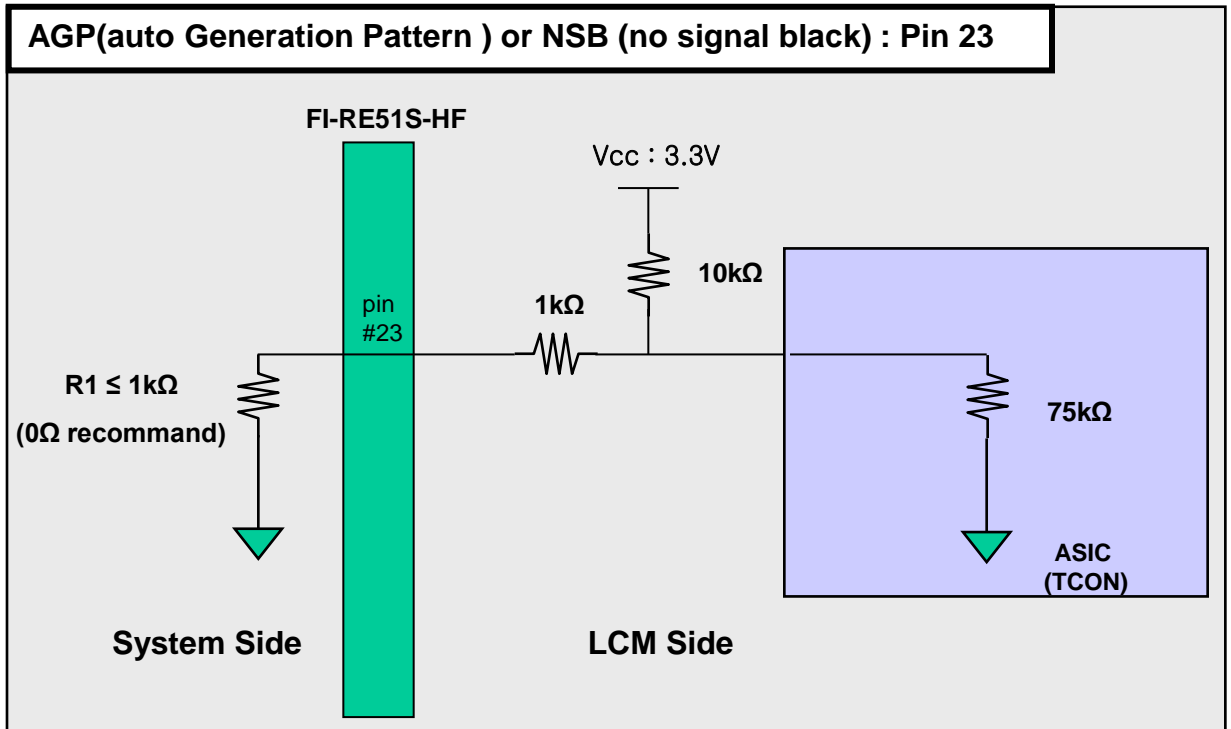

APPENDIX- IV-3

■ Option Pin Circuit Block Diagram

4) I2C (SDA/SCL) Selection Pin

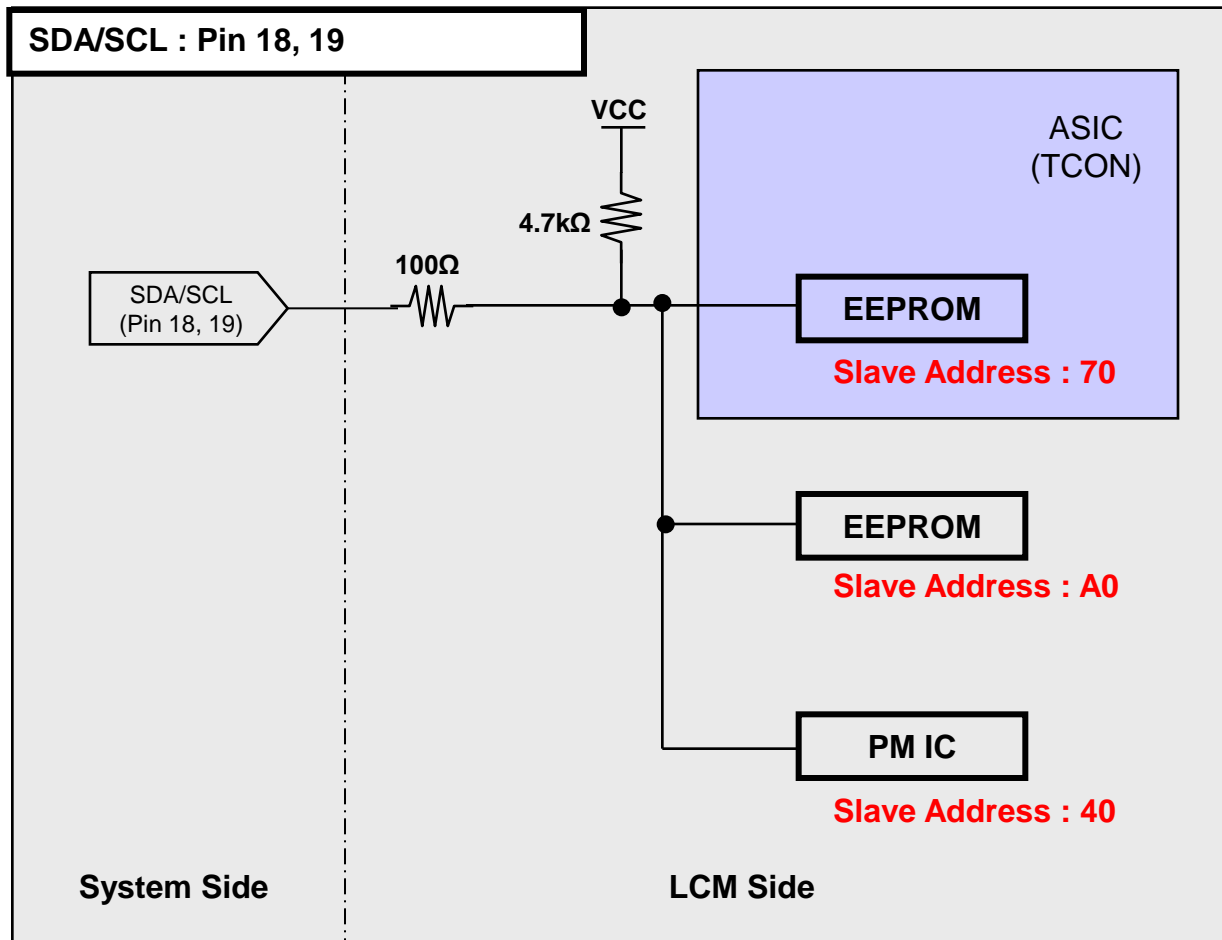

Note : I2C Line of Set Soc avoid using slave address 40, 70, A0 because LCD module uses those

APPENDIX- V

■ EXT_{VB}R-B & Local Dimming Design Guide

- 1) When L-Dim Enable is "L", Vertical Sync Signal = System Dimming with 100Hz or 120Hz frequency.
- 2) Local Dimming signals are synchronized with V-Sync Freq. of System in T-Con Board.
- 3) EXT_{VB}R-B Specification (VCC = 3.3V) @ Local Dimming
 - a) High Voltage Range : 2.5 V ~ 3.6 V
 - b) Low Voltage Range : 0.0 V ~ 0.8 V

(4pin)
 #4 : Local Dim Serial Clock
 #3 : Local Dimming Serial Data
 #2 : GND
 #1 : Vertical Sync signal

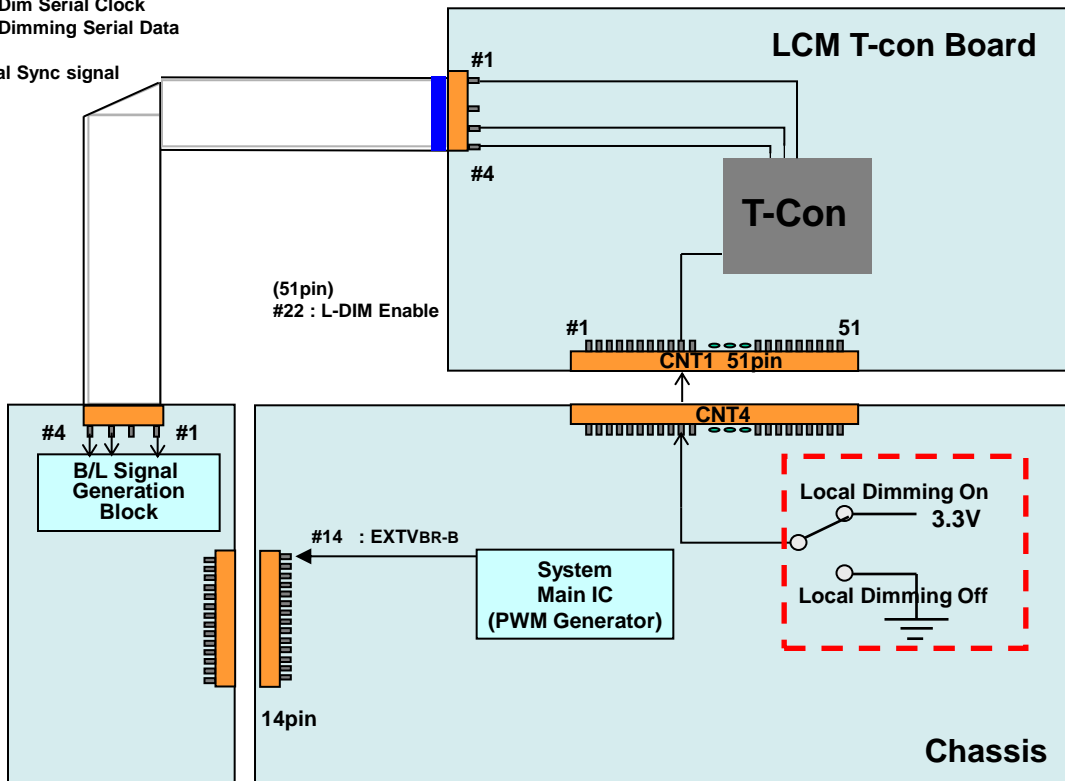

EXT _{VB} R-B Frequency	100 Hz for PAL 120 Hz for NTSC
Rising Time	MAX 10.0 μs
Falling Time	MAX 10.0 μs

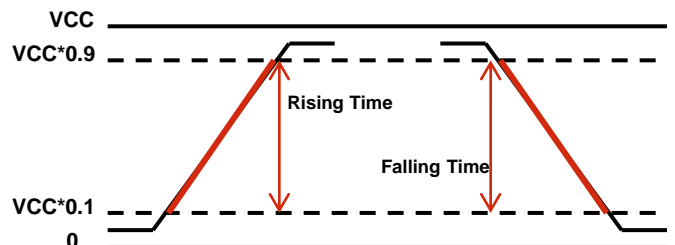

APPENDIX- VI

■ LED Array Electrical Spec

Item	Condition	Min	Typ	Max	Unit	Remark
Forward voltage(Vf)	Ifm=180mA	-	73.9	-	V	Ta=25°C
ΔVf^{*1}		-	-	1.7	V	

■ Forward Current vs. Forward Voltage

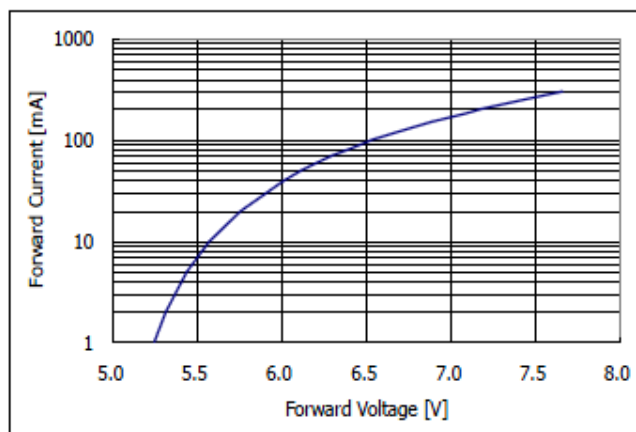

■ Ambient Temperature vs. Forward Voltage

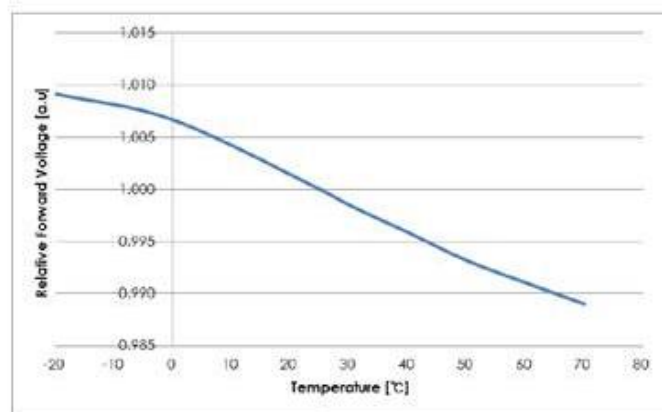

APPENDIX- VII-1

■ input mode of pixel data

Mode : Non-Division

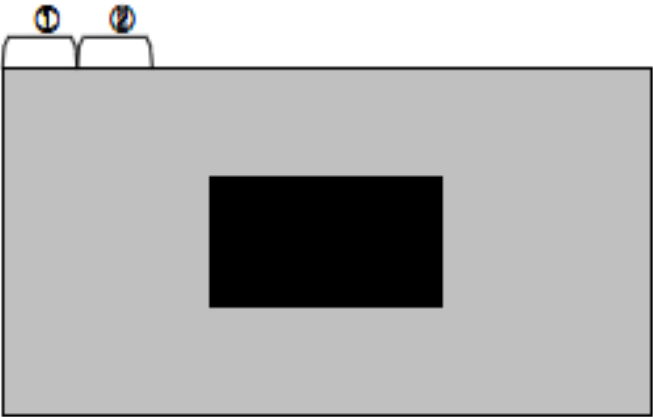

Lane	1 st Data	2 nd Data	Data#
Lane0	1	9	3833
Lane1	2	10	3834
Lane2	3	11	3835
Lane3	4	12	3836
Lane4	5	13	3837
Lane5	6	14	3838
Lane6	7	15	3839
Lane7	8	16	3840

APPENDIX- VIII

Gray to Gray Response Time Uniformity

This is only the reference data of G to G and uniformity for WE550EQN-3N model.

1. G to G Response Time :

Response time is defined as Figure3 and shall be measured by switching the input signal for “Gray (N) ” and “Gray(M)”.(32Gray Step at 8bit)

2. G to G Uniformity

The variation of G to G Uniformity , $\delta_{G \text{ to } G}$ is defined as :

$$\text{G to G Uniformity} = \frac{\text{Maximum}(G \text{ to } G) - \text{Typical}(G \text{ to } G)}{\text{Typical}(G \text{ to } G)} \leq 1$$

*Maximum (G to G) means maximum value of measured time (N, M = 0 (Black) ~ 1023(White), 128 gray step).

	0Gray	127ray	255Gray	...	895Gray	1023Gray
0Gray		TrR:0G→127G	TrR:0G→255G	...	TrR:0G→895G	TrR:0G→1023G
127Gray	TrD:127G→0G		TrR:127G→255G	...	TrR:127G→895G	TrR:127G→1023G
255Gray	TrD:255G→0G	TrD:255G→127G		...	TrR:255G→895G	TrR:255G→1023G
...
895Gray	TrD:895G→0G	TrD:895G→127G	TrD:895G→255G	...		TrR:895G→1023G
1023Gray	TrD:1023G→0G	TrD:1023G→127G	TrD:1023G→255G	...	TrD:1023G→895G	

3. Sampling Size : 2 pcs

4. Measurement Method : Follow the same rule as optical characteristics measurement.

5. Current Status

Below table is actual data of production on Sep. 26. 2014 (LGD RV Event Sample)

	G to G Response Time [ms]		Uniformity
	Min.	Max.	
# 1	3.52	8.65	5.46
# 2	2.70	8.89	6.07

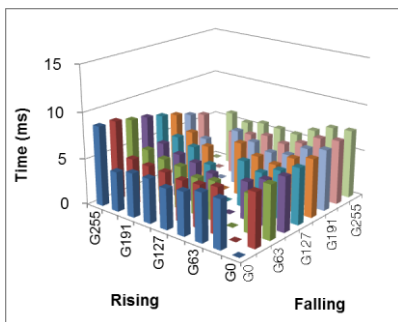

< # 1 >

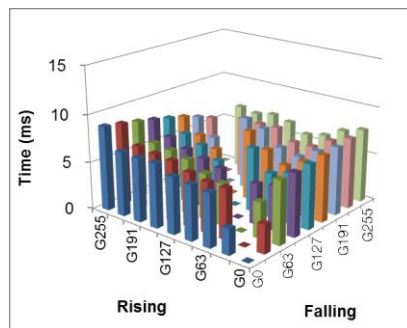

< # 2 >