



LCD185-101CTL1ARNTT

10.1" Edge Lit High Bright Wide Gamut

w/PCAP

1920*1200

Approvals	
Model Number	LCD185-101CTL1ARNTT
Datasheet Revision	2.0
Drawing Revision	F

Lincoln Technology Solutions
Confidential

Customer Approval	
Approved by: _____	Date: _____

Table of Contents

Revision History	4
Document Revision	4
Hardware Revision	5
General Specifications	6
Block Diagram	7
Pin Out-LCD	8
Pin Out – PCAP	10
Absolute Max Ratings – LCD	11
Absolute Max Ratings – PCAP	11
Electrical Characteristics – LCD	12
Electrical Characteristics – PCAP	12
Backlight Specifications	13
Backlight – ZHR-2 pinout	14
Timing Specifications - LCD	14
LVDS Timing	14
Power ON/OFF Sequence	15
Timing Specifications – PCAP	16
Optical Characteristics	17
Packaging	20
Quality & Inspection Criteria	21
Terminologies:	21
Inspection Conditions	25
Acceptance Criteria Table	26
Appendix 1: Drawing	28

Revision History

Document Revision

Date	Version #	Description	Created by	Checked by	Quality Approval By	Approved By
10.19.2021	0.1	Preliminary Release	Lexie H.	Scott S.	--	--
9.1.2022	1.0	Luminance: 1000nits was 2000nits. Updated mechanical drawing, outline dimensions: 227.43mm, was 246.16mm. 153.25mm, was 164.80mm. 6.9mm, was 7.15mm	Scott S.	Kevin. B	--	Jesse H.
11.21.2022	1.1	Corrected driver IC callout from Himax HX8290-B to Sitronix ST5892B in general specifications table. Sitronix ST5892B was HX8290-B in Timing Specifications – LCD section, updated electrical characteristics – LCD table for Sitronix driver IC	Dom A.	Zak H.	--	Jesse H.
12.1.2022	1.2	Updated drawing.	Dom A.	Zak H.	--	AJ
12.8.2022	1.3	Corrected color coordinate values: Wx = .310 was .288, Wy = .330 was .355	Dom A.	Zak H.	--	Jesse H.
5.1.2024	1.4	Added note regarding backlight specifications	ST	RT	--	JH
5.22.2025	1.5	Added Quality Approval column to Document Revision table, General Specifications table: corrected outline dimensions, added driver IC Sitronix ST5892B or Himax HX8290-B, added LED color, added quantum dot technology, and corrected surface treatment to include anti-fingerprint; corrected block diagram, updated Electrical Characteristics – LCD, revised Timing Specifications to Sitronix ST5892B or Himax HX8290-B, updated Optical Characteristics Note 1, corrected packaging	ST	KV	TT	JH
7.25.2025	2.0	Updated drawing, updated Hardware Revision from 1.0 to 2.0, updated luminance in General	ST	KV	TT	JH

		Specifications table, updated Electrical Characteristics-LCD table, updated Backlight Specifications, added Power vs. Luminance graph, updated Optical Characteristics				
--	--	--	--	--	--	--

Hardware Revision

Date	Version #	Description
8.19.2022	1.0	Production Release
6.5.2025	2.0	FOG part updated

Lincoln Technology Solutions
Confidential

General Specifications

Item	Specification	Unit
Active Area	216.81 (H) X 135.50 (V)	mm
Backlight Type	Edge Lit	-
Display Mode	Normally Black	-
Display Size	10.1	inches
Driver IC	Sitronix ST5892B or Himax HX8290-B	
Interface	LVDS	-
LCD Color Depth	TFT LCD 8bit 16.7M colors	-
LED Color	Blue	-
Luminance	3000	cd/m ²
Number of Dots	1920 (H) X 1200 (V)	-
Operating Temperature	-20 to 70	°C
Outline Dimensions	227.43 (H) X 153.25 (V) X 7.15 (D)	mm
Quantum Dot Technology	QDEF	
Sub Pixel Pitch	37.64 (H) X 112.92 (V)	um
Surface Treatment	Cover lens with Anti-Reflective and Anti-Fingerprint	-
Touch Panel	PCAP GT928	-
Viewing Direction	Free	-

Block Diagram

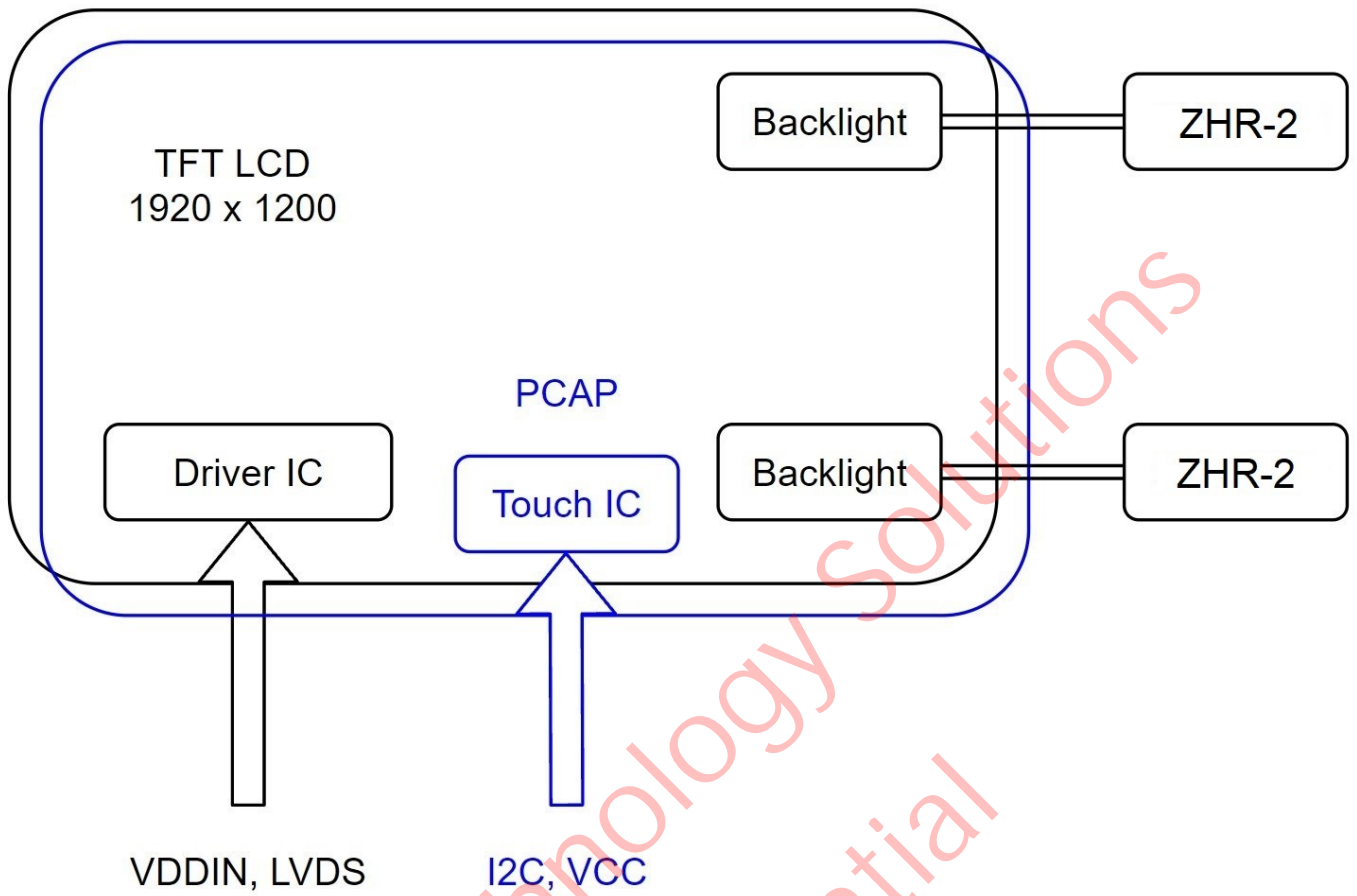

Lincoln Technology Solutions
Confidential

Pin Out-LCD

The 10.1" LCD has a Hirose 45 position, 0.5mm pitch, MPN: FH34SRJ-45S-0.5SH (50)

Note: First pin name is the LTS pin name but for clarity, we are providing the second pin name based on the OpenLDI spec.

Number	Symbol	I/O	Description
1	NC	-	Reserved (No connection)
2	NC	-	Reserved (No connection)
3	NC	-	Reserved (No connection)
4	NC	-	Reserved (No connection)
5	NC	-	Reserved (No connection)
6	GND	P	Ground
7	ELV3P / A7P	I	Even LVDS Positive Data Signal
8	ELV3N / A7N	I	Even LVDS Negative Data Signal
9	GND	P	Ground
10	ELV2P / A6P	I	Even LVDS Positive Data Signal
11	ELV2N / A6N	I	Even LVDS Negative Data Signal
12	GND	P	Ground
13	ELVCLKP / CLK1P	I	Even LVDS Positive CLK Signal
14	ELVCLKN / CLK1N	I	Even LVDS Negative CLK Signal
15	GND	P	Ground
16	ELV1P / A5P	I	Even LVDS Positive Data Signal
17	ELV1N / A5N	I	Even LVDS Negative Data Signal
18	GND	P	Ground
19	ELV0P / A4P	I	Even LVDS Positive Data Signal
20	ELV0N / A4N	I	Even LVDS Negative Data Signal

21	GND	P	Ground
22	OLV3P / A3P	I	Odd LVDS Positive Data Signal
23	OLV3N / A3N	I	Odd LVDS Negative Data Signal
24	GND	P	Ground
25	OLV2P / A2P	I	Odd LVDS Positive Data Signal
26	OLV2N / A2N	I	Odd LVDS Negative Data Signal
27	GND	P	Ground
28	OLVCLKP / CLK0P	I	Odd LVDS Positive CLK Signal
29	OLVCLKN / CLK0N	I	Odd LVDS Negative CLK Signal
30	GND	P	Ground
31	OLV1P / A1P	I	Odd LVDS Positive Data Signal
32	OLV1N / A1N	I	Odd LVDS Negative Data Signal
33	GND	P	Ground
34	OLV0P / A0P	I	Odd LVDS Positive Data Signal
35	OLV0N / A0N	I	Odd LVDS Negative Data Signal
36	GND	P	Ground
37	NC	-	Reserved (No connection)
38	NC	-	Reserved (No connection)
39	NC	-	Reserved (No connection)
40	NC	-	Reserved (No connection)
41	VDDIN	P	Power Supply (3.3V)
42	VDDIN	P	Power Supply (3.3V)
43	VDDIN	P	Power Supply (3.3V)
44	VDDIN	P	Power Supply (3.3V)
45	VDDIN	P	Power Supply (3.3V)

Pin Out – PCAP

The PCAP tail has gold plated contacts spaced at 0.5mm pitch. It is recommended to use a mating connector such as Hirose 6 position, 0.5mm pitch, MPN: FH34SRJ-6S-0.5SH (50).

Number	Symbol	I/O	Description
1	VCC	P	Power Supply (3.3V)
2	RSTN	I	Reset signal (1.8V)
3	INT	O	Interrupt out (1.8V)
4	SCL	I	Serial Clock (1.8V)
5	SDA	I/O	Serial Data (1.8V)
6	GND	P	Ground

Lincoln Technology Solutions
Confidential

Absolute Max Ratings – LCD

Item	Symbol	Value	Unit
Power Supply Voltage	VDDIN	-0.3 – 3.6	V
Operating Temperature	Topr	-20 to 70	°C
Storage Temperature	Tstg	-30 to 80	°C
Operating Humidity	Hop	10 to 90	%RH

Absolute Max Ratings – PCAP

Item	Symbol	Value	Unit
Operating Voltage	VCC	-0.3 – 3.47	V
I/O Supply Voltage	IOVCC	-0.3 – 3.47	V

Lincoln Technology Solutions

Confidential

Electrical Characteristics – LCD

Item	Symbol	Min	Typ	Max	Unit	Test Condition
Power Supply Voltage	VDDIN	3.0	-	3.6	V	-
Power Supply Current	IDD	-	330	520	mA	Note 1
Power Consumption	PLCD	-	1.08	1.7	W	
Rush Current	IRUSH	-	-	2.0	A	Note 2
Common mode voltage	V _{CM}	-	1.2	-	V	
Differential input high threshold voltage	V _{TH}	-	-	0.1	V	V _{CM} = 1.2V
Differential input low threshold voltage	V _{TL}	-0.1	-	-	V	V _{CM} = 1.2 V
Differential termination	Z _{ID}	80	100	120	Ω	-

Notes:

1. The current draw and power consumption specified is for VDDIN = 3.3V, Frame rate Fv = 60Hz and Clock frequency = 80MHz.
2. The duration of rush current is about 2ms, and rising time of power input is 1ms (min).

Electrical Characteristics – PCAP

Item	Symbol	Min	Typ	Max	Unit	Test Condition
Power Supply Voltage	VCC	2.8		3.3	V	-
I/O Supply Voltage	IOVCC	-	1.8	1.95	V	-
Power Supply Current	ICC	-	13.37	-	mA	Ta = 25 °C
Input Voltage	V _{Ih}	0.75*IOVCC	-	IOVCC+0.3	V	-
	V _{Il}	-0.3	-	0.25*IOVCC	V	-
Output Voltage	V _{oh}	0.85*IOVCC	-	-	V	-
	V _{ol}	-	-	0.15*IOVCC	V	-

Backlight Specifications

This design has 2 LED rails to achieve maximum brightness. JST ZH series connectors were chosen for ease of integration. The backlight wiring has been pinned out to a 2 position, 1.5 mm pitch connector with part number ZHR-2, an example mating connector part number is S2B-ZR-SM2-TF. The supply current mentioned below is the sum, i.e., 300 mA per backlight connector is required for a total of 600 mA (typical) at 3000 NITS.

Voltage (V) Typical	Current (mA) Typical	Condition
26.40	200	1000 NITS
26.68	300	1500 NITS
27.30	600	3000 NITS

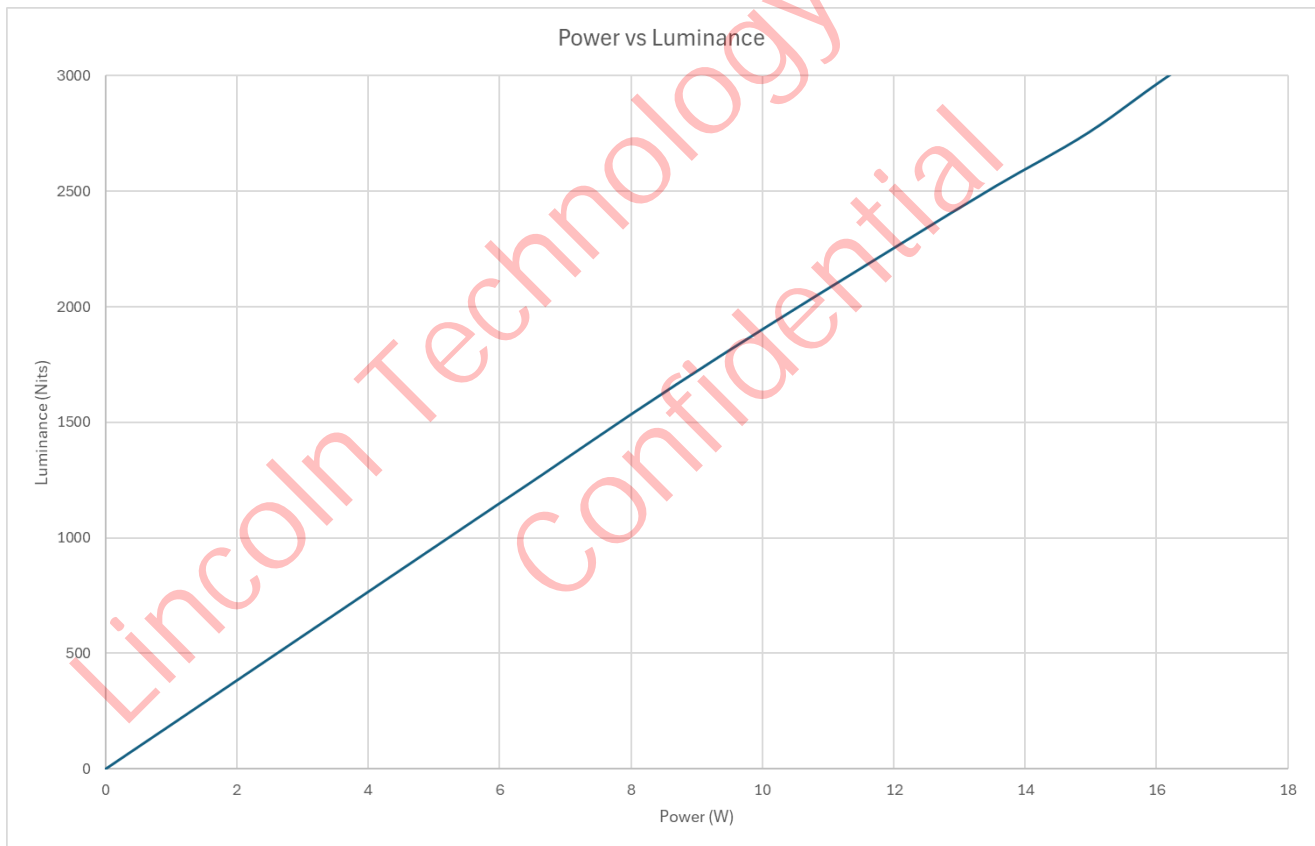

Backlight – ZHR-2 pinout

Number	Name	I/O	Description
1	LEDA	P	BL Power positive
2	LEDK	P	BL Power negative

Timing Specifications - LCD

Refer to Sitronix ST5892B or Himax HX8290-B datasheet.

LVDS Timing

Symbol	Symbol	Min	Typ	Max	Unit
DCLK Frequency	Fdclk	74.5	77.56	85	MHz
Horizontal display area	Thd	960			DCLK
HSYNC period time (H)	Th	989	1040	1248	DCLK
Horizontal blank	Thb	29	80	288	DCLK
HSYNC pulse width	Thp	2	10	255	DCLK
HSYNC back porch	Thbp	3	6	255	DCLK
HSYNC front porch	Thfp	24	64	260	DCLK
Vertical display area	Tvd	1200			H
VSYNC period time	Tv	1243	1243	1560	H
Vertical blank	Tvb	43	43	360	H
VSYNC pulse width	Tvp	4	4	20	H
VSYNC back porch	Tvbp	20	20	255	H
VSYNC front porch	Tvfp	19	19	260	H
Frequency	Fv	-	60	-	Hz

Power ON/OFF Sequence

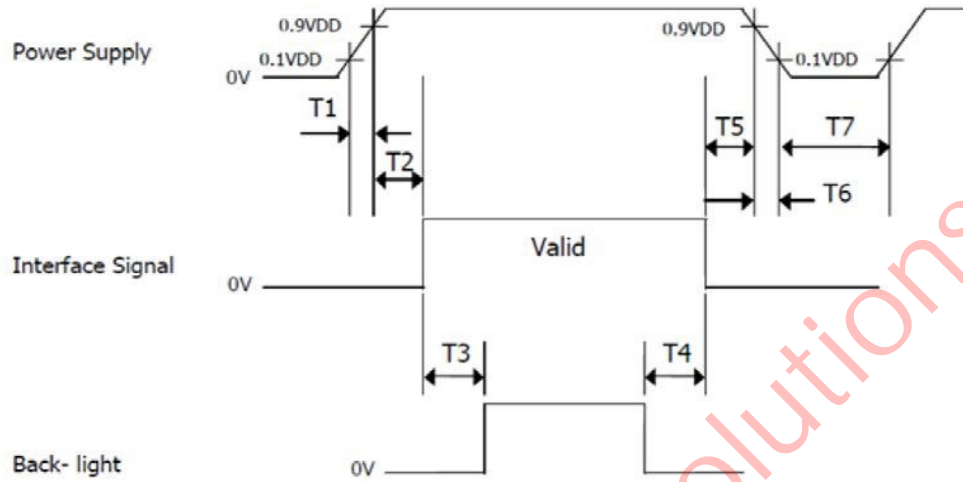

Parameter	Values			Units
	Min	Typ	Max	
T1	0	-	10	ms
T2	0	-	50	ms
T3	200	-	-	ms
T4	500	-	-	ms
T5	0	-	50	ms
T6	0	-	10	ms
T7	500	-	-	ms

Timing Specifications – PCAP

Refer to GT928 datasheet.

Standardized timings provided for reference.

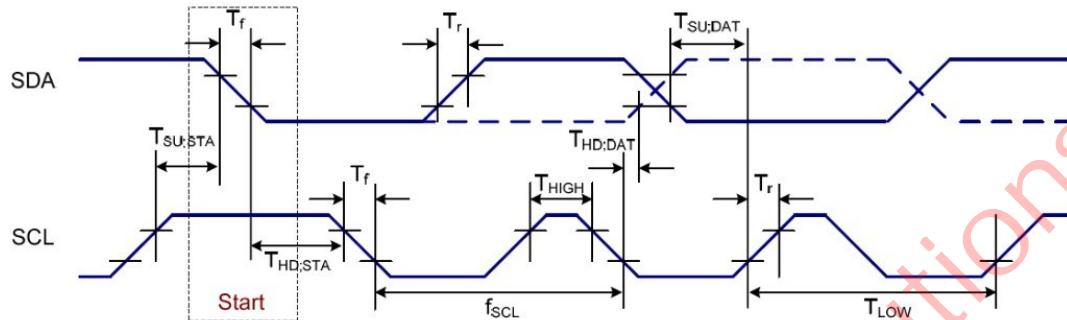

Symbol	Parameter	Min	Typ	Max	Unit
f_{SCLK}	SCL clock frequency	50	100	400	kHz
T_{LOW}	SCL clock LOW period	1.3	-	-	us
T_{HIGH}	SCL clock HIGH period	0.6	-	-	us
$T_{SU;DATA}$	Data set-up time	100	-	-	ns
$T_{HD;DATA}$	Data hold time	0	-	0.9	us
T_r	SCL and SDA rise time	20	-	300	ns
T_f	SCL and SDA fall time	20	-	300	ns
T_f	SDA fall time for read out	20	-	1000	ns
C_b	Capacitive load represented by each bus line	-	-	400	pF
$T_{SU;STA}$	Setup time for a repeated START condition	0.6	-	-	us
$T_{HD;STA}$	START condition hold time	0.6	-	-	us
$T_{SU;STO}$	Setup time for STOP condition	0.6	-	-	us
T_{SW}	Tolerable spike width on bus	-	-	50	ns
T_{BUF}	Bus free time between a STOP and START condition	4.7	-	-	us

Optical Characteristics

All measurements taken after minimum runtime of 25 minutes.

Item	Symbol	Conditions	Specification			Unit	Note	
			Min	Typ	Max			
Contrast Ratio	CR	Normal Viewing Angle	800	1000		-	(1)(3)(5)	
Response Time	Tr Tf	Ta = 25°C	-	30	35	ms	(1)(4)	
Viewing Angle	Hor.	X-	CR>10	75	80	-	Deg	(3)(5)
		X+		75	80	-	Deg	
	Ver.	Y+		75	80	-	Deg	
		Y-		75	80	-	Deg	
Chromaticity	Red	Rx	Ta = 25 °C	-	.6942	-	-	
		Ry		-	.3045	-	-	
	Green	Gx		-	.2444	-	-	
		Gy		-	.7201	-	-	
	Blue	Bx		-	.1548	-	-	
		By		-	.0750	-	-	
	White	Wx		-	.3472	-	-	
		Wy		-	.3464	-	-	
Color Gamut Coverage			-	108	-	%	DCI-P3	
Color Gamut Ratio			-	99	-	%	DCI-P3	
Luminance	L	Ta = 25 °C	-	3000	-	cd/m2	(1)	
Uniformity	U		-	92	-	%	(2)	

Note 1: Measurement setup

The LCD module should be stabilized at a given temperature for 25 minutes to avoid abrupt temperature change during measurement. After temperature saturation, measurement should be executed. Measurements are conducted with a colorimeter with the aperture in contact with the display.

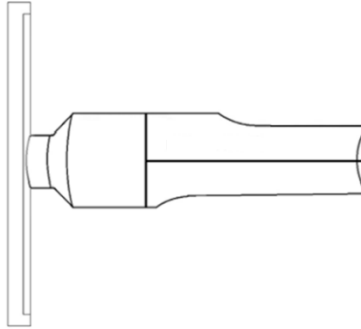

Note 2: Brightness Uniformity

Brightness uniformity = (Minimum Luminance of 9 points / Max Luminance of 9 points) * 100

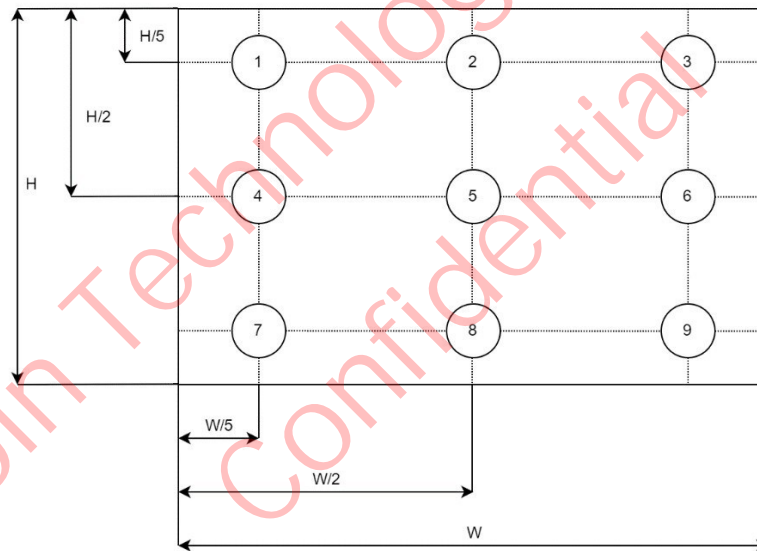

Note 3: Viewing Angle

Definition of viewing angle for Y+/- and X+/- is as follows.

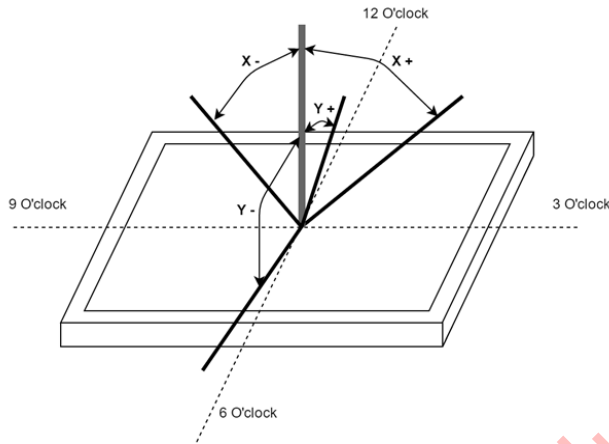

Note 4: Response Time

Definition of response time as follows below.

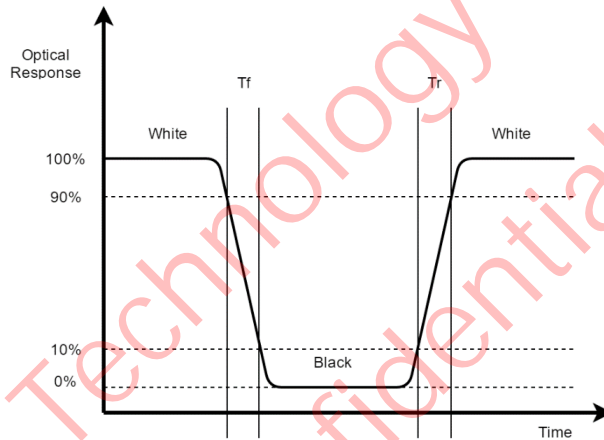

Note 5: Contrast Ratio

Definition of Contrast Ratio is as follows.

Contrast measurements shall be made at a viewing angle of 0° at the center of the surface.

$$CR = \frac{\text{Luminance when displaying White}}{\text{Luminance when displaying Black}}$$

Packaging

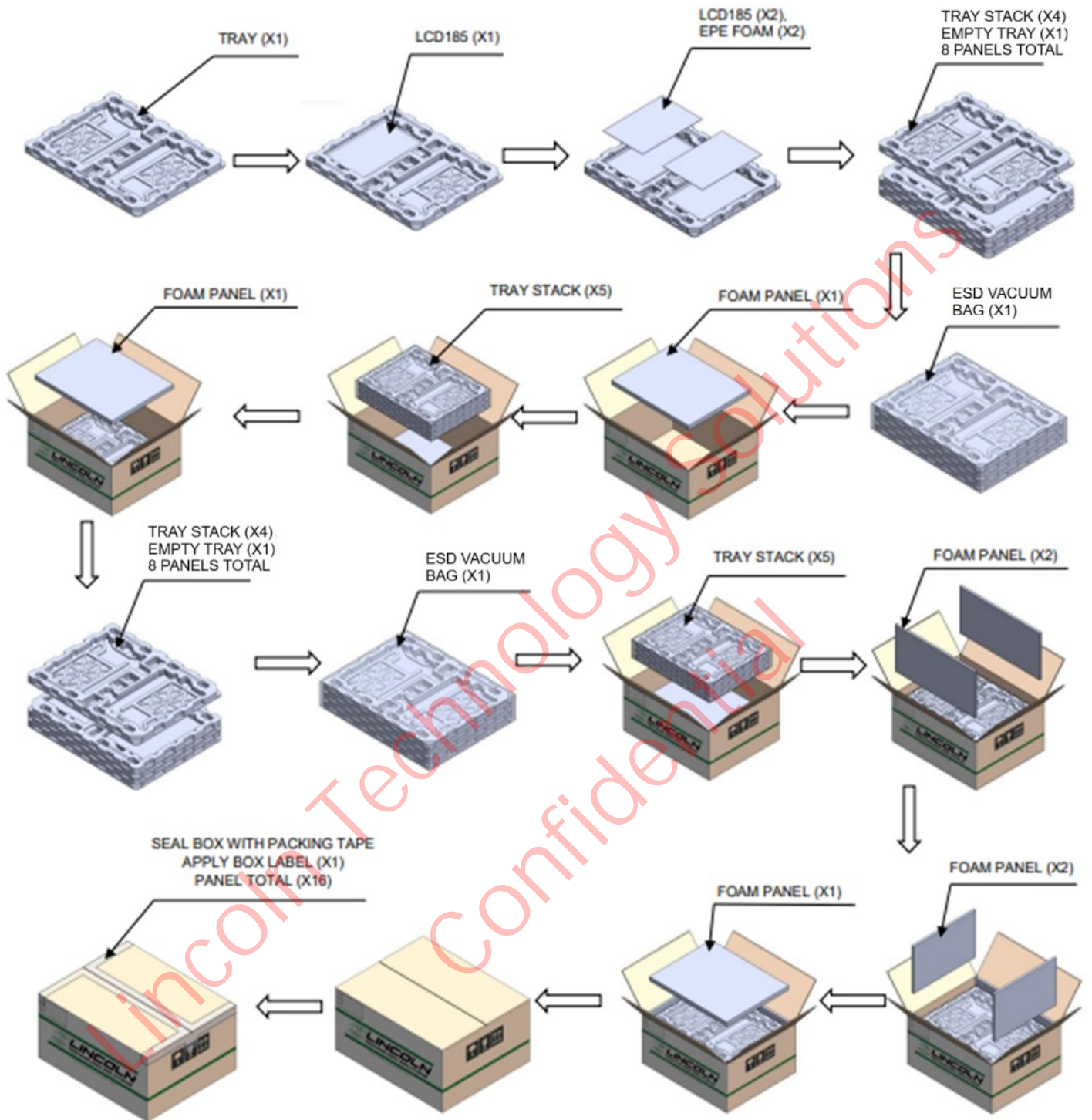

Quality & Inspection Criteria

Terminologies:

LCD: Liquid Crystal Display; Each pixel contains three dots of R, G, and B (sub-pixel).

Bright Dot: 1 sub-pixel is a dot. Defects should be larger than 1/2 of a sub-pixel. Dots that are not visible through a 5% ND filter or smaller than 1/2 of sub-pixel size will not be counted as a dot defect.

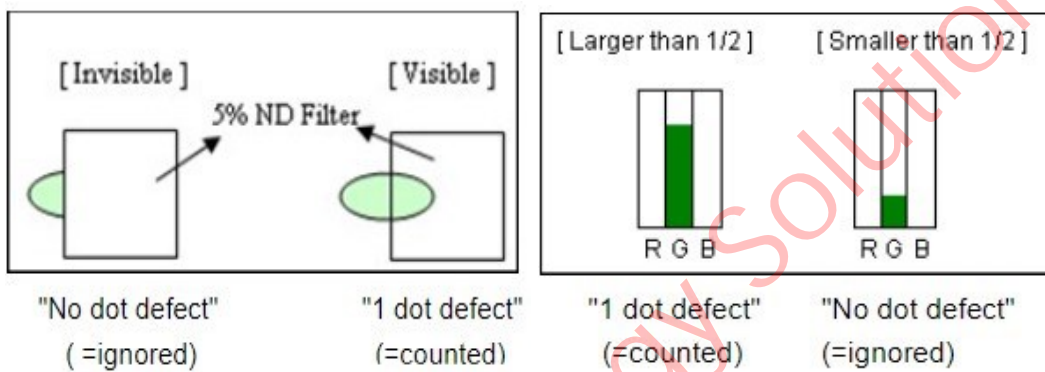

Dark Dot: Any single sub-pixel that does not light up in a white screen or another non-black screen is called a dark dot.

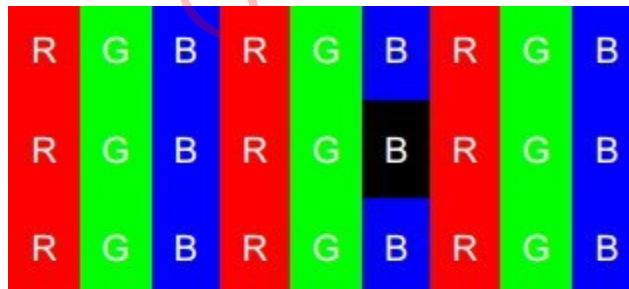

Two adjacent dots (horizontal direction): Use the bright dot illustration as an example to demonstrate two horizontal consecutive dots.

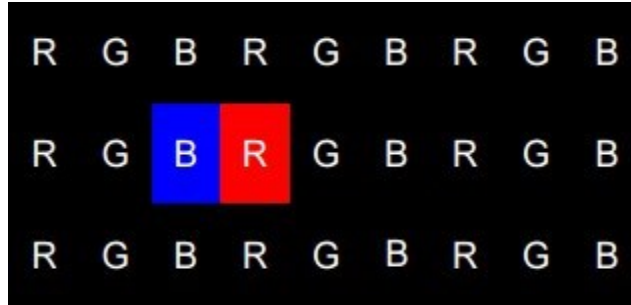

Two adjacent dots (vertical direction): Use the bright spot illustration as an example to demonstrate two vertical consecutive dots.

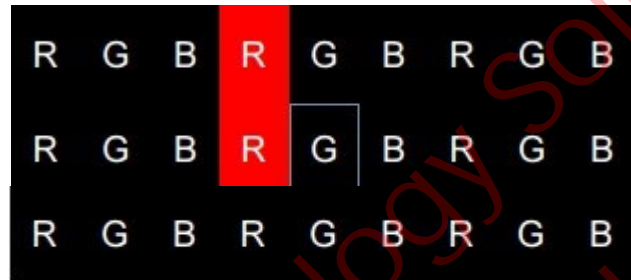

Two adjacent dots (bevel direction): Use the bright spot illustration as an example to demonstrate two consecutive dots in the bevel direction.

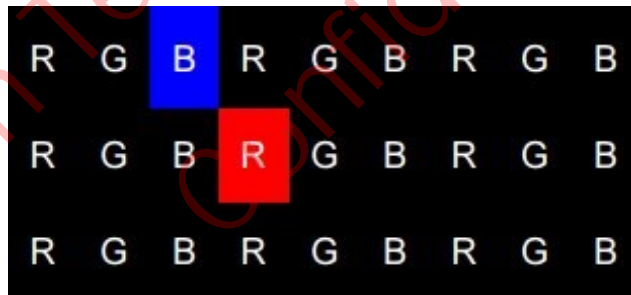

Three or more adjacent dots (horizontal): Use the bright spot illustration as an example to demonstrate three or more consecutive horizontal and vertical dots.



Illustration of spacing between two dots: (Distance is the relative distance between the X-axes of the two dots or the relative distance between the Y-axes of the two dots, whichever is larger)

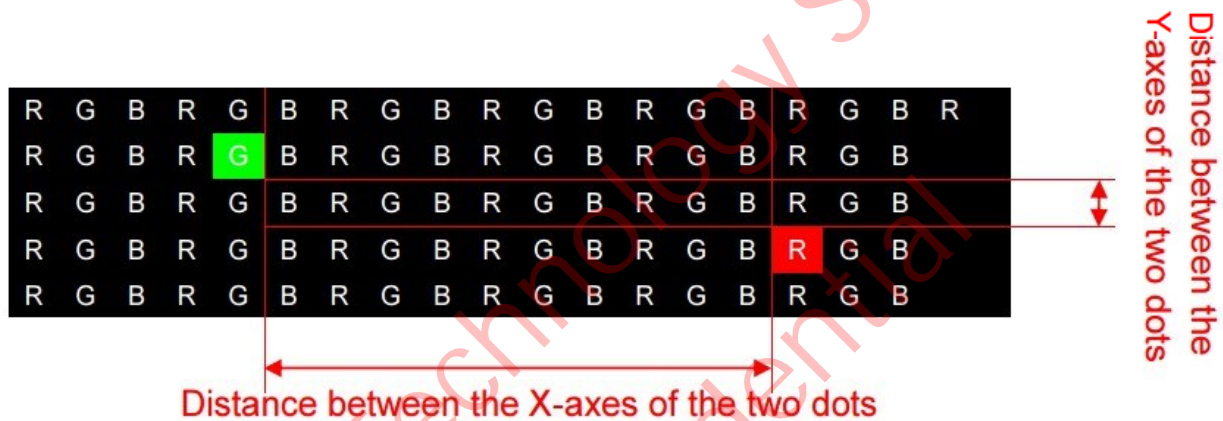

Functional Test

The LCD display testing program should display the following screens in order: all red, all green, all blue, all white, all gray, all black.

Inspection Requirements

After booting the system (single illumination), there are no non-display, unlit backlight, dark backlight, blinking, or other abnormal signs, and there are no bright lines, dark lines, or bright rims/leakage of light close to the LCD bezel.

Newton's Ring

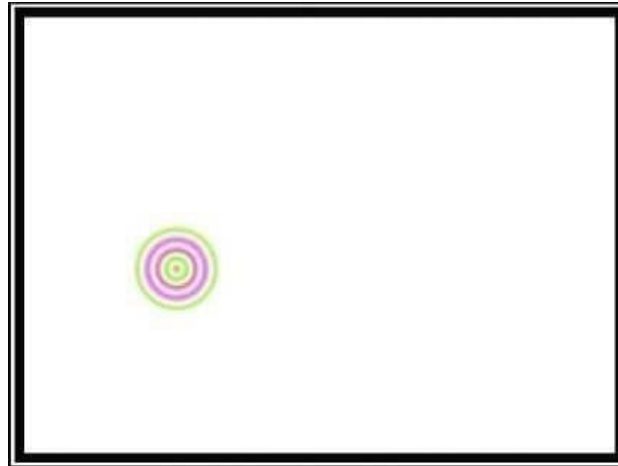

Under high temperature and high humidity conditions, uneven deformations caused by heat in different layers of the LCD module will result in the display of an all-white screen. However, this condition can be recovered when temperature is resumed under normal circumstances. A specific determination can be conducted according to the operating conditions and storage conditions defined in the product's technical specifications. Any exception will be negotiated and mutually agreed by both parties. (Ripples are not permitted at fixed locations. For ripples at non-fixed locations, they are OK if they disappear within two seconds.)

LCD blaze

Uneven internal LCD installation, surface deformation of the LCD polarizer, internal structural interference of the LCD module, damaged LCD backlight plates, and other factors may cause partial fading of color on the LCD display. When observed from a certain incident angle (upper 10°, lower 3°, 40° on both sides), they will appear as white cicatrices, typically about the size of a grain of rice. In serious cases, they accumulate in large patches or stripes, appear in different degrees under various colors (red, blue, green, black, gray, white), and are especially obvious under an all-gray screen. Blazes with diameters $\geq 0.5\text{mm}$ are not allowed: for those with diameters under 0.5 mm, 2 are acceptable if the space between them is $\geq 15\text{mm}$. Card chromatic aberration ratio versus ND Filter: $1.0 + 0.3$ standard = 5% ND Filer (see definition of Mura)

Mura

Mura refers to the unevenness and irregularity that is visible in the image. It is difficult for visual inspection to recognize the non-uniform brightness or mura. Mura detection is subjective and therefore doesn't have pass/fail criteria. There are several precautions to take which can avoid mura. Avoid high ambient temperatures around the module, frame warpage and high temperature operation over long periods of time. Utilize screen savers to avoid mura.

Inspection Conditions

Inspection distance should be 35cm ± 5cm with a FujiFilm ND-LCD 5% filter approximately 5cm from the backlight surface.

Viewing angle: 90° ± 5°.

Room temperature:

23+/- 2°C Humidity: 60

+/- 10%

Inspection Ambient Illumination: 300-700 LUX

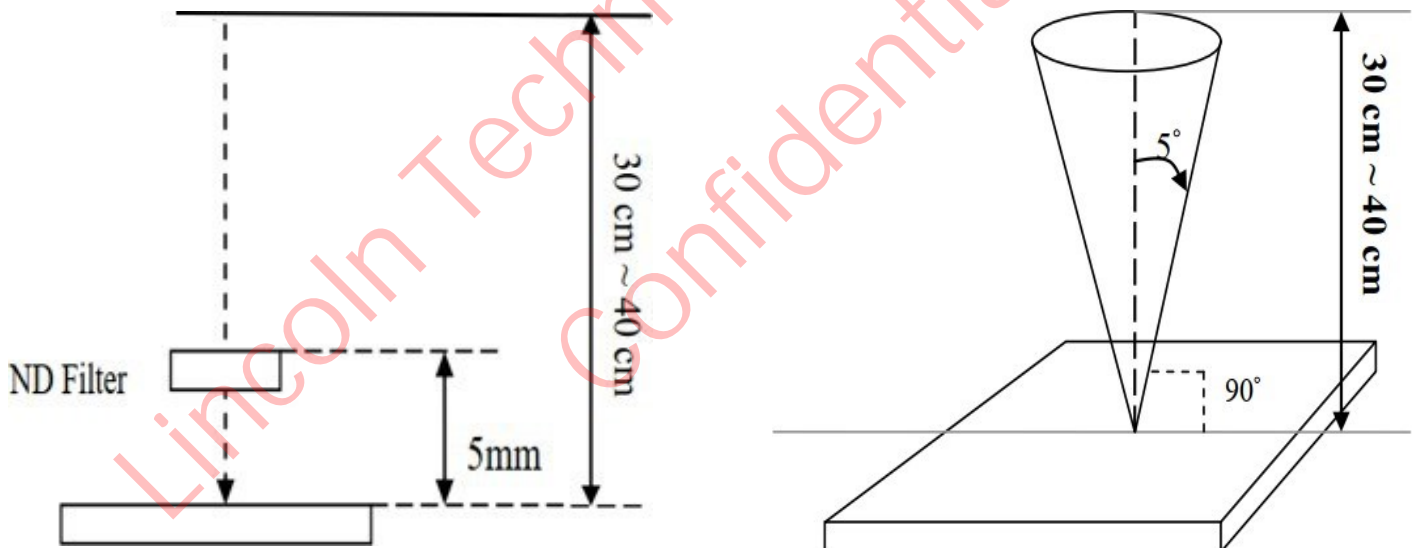

Acceptance Criteria Table

There should be no corrosion or cracking, or an uneven coating layer on LCD display surface, and there should be no sign of coagulation, flaking, cracking, or wear. The definition of minor defects and acceptance criteria are shown in the following table:

Item	Size	Unit	Acceptance Qty.
Unfelt scratch visible with backlight off.	W < 0.05	mm	Ignore
	W > .05 and < .10 L > .3 and < 3.0	mm	4
	W > .10 or L > 3.0	mm	none
	Visible with backlight on		none
Felt scratch	None allowed		
Dent visible with backlight off	D < .2	mm	Ignore
	D > .2 and < .5	mm	5
	Spacing between defects must be > 30mm		
	D > .5	mm	none
	Visible with backlight on		none
Bubble visible with backlight off	D < .2	mm	Ignore
	D > .2 and < .5	mm	5
	D > .5	mm	none
	Visible with backlight on		none

Item	Size	Unit	Acceptance qty.
Foreign material (line shape) visible with backlight on	W > .05 and < .10 L > .3 and < 2.0	mm	4
	W > .10 or L > 2.0	mm	none
Foreign material (dot shape) visible with backlight on	D < .2	mm	Ignore
	D > .2 and < .5	mm	5
	D > .5	mm	none
Bright dot defect (lit)	1 dot	-	4
	2 adjacent dots	-	0
Dark dot defect (not lit)	1 dot	-	5
	2 adjacent dots	-	2
	3 adjacent dots	-	0

Lincoln Technology Solutions
Confidential

Appendix 1: Drawing

Lincoln Technology Solutions
Confidential

DRW REV.	HW REV.	DESCRIPTION	DATE	APPROVED
A	1.0	INITIAL ISSUE	2022/7/27	QIN
B	1.0	REMOVED TRAILING ZEROS, ADDED ORIGIN(0,0).	2022/9/1	QIN
C	1.0	REMOVED THE NOTE, UPDATED GENERAL TOLERANCE TABLE	2022/11/24	JK
D	1.0	UPDATED FPC DIMENSIONS	2023/9/6	JH
E	1.0	ANNOTATION UPDATES	2024/5/3	JH
F	2.0	FOG PART UPDATED	2025/6/5	JH

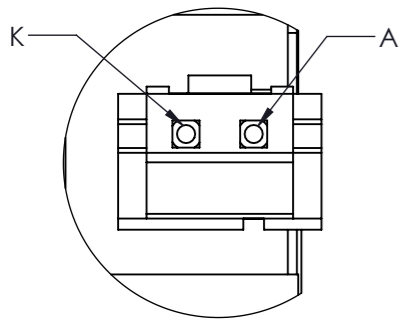
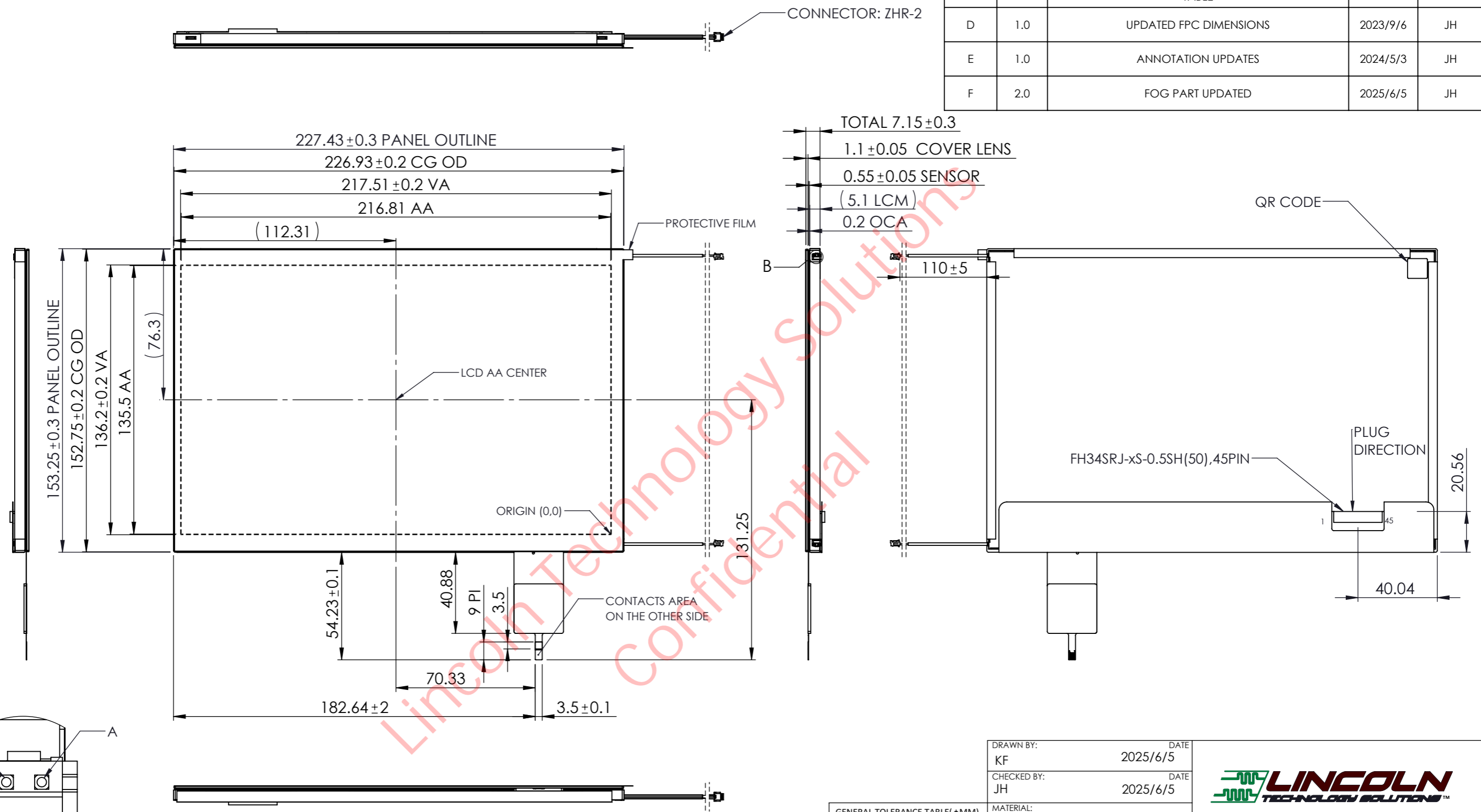

GENERAL TOLERANCE TABLE (±MM)	
L ≤ 20	0.1
20 < L ≤ 50	0.2
50 < L ≤ 100	0.25
100 < L ≤ 200	0.3
L > 200	0.5
SCALE: 1:2	SHEET 1 OF 1
DO NOT SCALE DRAWING	

DRAWN BY: KF	DATE 2025/6/5
CHECKED BY: JH	DATE 2025/6/5
MATERIAL: N/A	
FINISH: N/A	
COMMENTS: ALL DIMENSIONS ARE IN MILLIMETERS.	



DESCRIPTION 10.1" LCD HBWG W/PCAP GENERIC		
PART NO. LCD185-101CTL1ARNTT	HW REV. 2.0	DRW REV. F

THE INFORMATION CONTAINED IN THIS DRAWING IS THE SOLE PROPERTY OF LINCOLN TECHNOLOGY SOLUTIONS (LTS) AND SHALL NOT BE REDISTRIBUTED. ANY REPRODUCTION IN PART OR AS A WHOLE WITHOUT THE WRITTEN PERMISSION OF LTS IS PROHIBITED.