



KYOCERA International, Inc.

46723 Five Mile Rd.
Plymouth, MI 48170
Tel: 248-921-0410
<http://americas.kyocera.com>

Product Change Notification

Date: August 28, 2020

Dear Valued Customer,

Thank you for choosing Kyocera as your LCD solution provider. We appreciate the opportunity to support your business. This letter is to inform you of a packaging change to the following parts.

1. Product

TCG057QVL**_***	5.7" QVGA
TCG057VGL**_***	5.7" VGA

2. Background

In order to help minimize freight costs, we will be changing the packaging specification for some of our 5.7" QVGA and 5.7" VGA parts. Part list is provided in a separate file. We have confirmed that this new packaging has passed our standard packaging drop test.

3. Product Changes

	Current	New
Quantity	40pcs/box	60pcs/box
Weight	11.4Kg	12.5Kg

Please refer to Appendix 1 for details of the changes to the outer box dimensions and packaging method.

4. Schedule

The packaging change will start from December 2020 production.

5. Packaging Evaluation Test

Please refer to Appendix 2



Appendix 1

1) Outer box size change

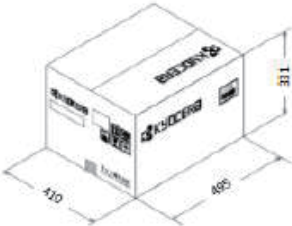
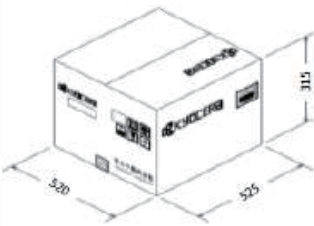
	Current	New
Length x Width x Height	410 x 495 x 331	520 x 525 x 315
Outline drawing		

Current : 410 x 495 x 331 (mm)

New : 520 x 525 x 315 (mm)

2) Packaging method

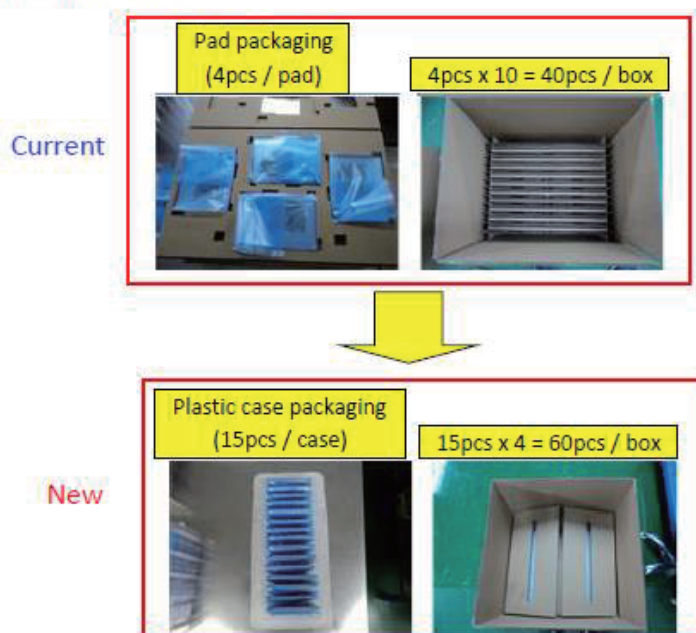

W



Appendix 2

Evaluation results

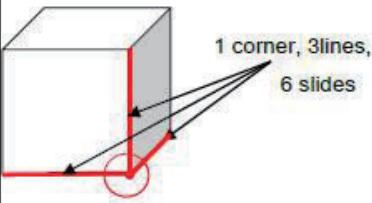
Test item	Test Conditions	Criterion	Result
Packaging vibration test	Interval: 10~55~10Hz, 1minute Vibration width: 0.15mm Test time: 2 hours in each direction X, Y, Z	No abnormal appearance and function are found.	Passed
Packaging drop test	1) Side of the drop and number of the drop : 1 corner, 3 lines, 6 sides 2) Height : 100cm 3) Conditions: Packaged condition 	No abnormal appearance and function are found.	Passed

We apologize for the inconvenience this notice may cause. Thank you for your understanding and your cooperation. If you have any questions, please contact your KYOCERA sales representative.

Sincerely yours,

KYOCERA International, Inc

Display Division